

PERCo

Security equipment manufacturer



Technical catalogue

- Turnstiles and gates
- IP-Stiles
- Boom barriers
- Locks



5



10



22



27



31

Waist-high turnstiles and gates..... p. 36



39



47



55



65



71



104



142



148

Waist-high railings. Passage zone modeling.....

p. 162



162

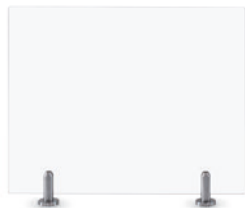

171

Full height turnstiles, gates, railings..... p. 173



173



193



204

Boom barriers

p. 222



222

Locks

p. 230



233



IP-STILES

General information..... p. 4



• KT08.3A IP-Style p. 5



• KT02.9B IP-Style p. 10



• KT02.9 IP-Style p. 16



• KT05.9A IP-Style p. 22



• IRP-01 Reader post p. 27

• IC-05 Card capture reader p. 31

PERCo IP-Stiles are ready-for-use access control systems (ACS) based on IP-technologies. The IP-Style delivery set includes:

- IP-Style housing with built-in:
 - controller (Ethernet interface)
 - two built-in proximity card readers (EMM/HID/MIFARE)
 - two fingerprint scanners (KTO2.9B)
 - PERCo Software
- RC-panel

Built-in equipment simplifies the installation process and does not require extra space. In order to install the IP-Stiles, the housing should be fixed with anchor bolts, and the IP-Style should be connected to the Ethernet network and to the 12 V DC power supply.

The IP-Style can operate both as a standalone unit and as a part of PERCo-Web system. Free software allows arranging ACS featuring basic necessary functions but with some restrictions. Basic PERCo-WB software is limited to the number of cards (max. 100 cards).

A trial version of the full-featured software can be used (60 days for PERCo-Web), after that the required full software package and the license are to be ordered.

Up to 8 lock controllers with integrated readers (EMM/HID) can be connected to the IP-Style controller which allows equipping 8 rooms with access control systems. More information about controllers can be found on PERCo website in the Readers & controllers section.



+55 -20 temperature range	12V operating voltage	2 passage directions	30 persons/min
"anti-panic" barrier arms	Ethernet interface	2 readers	50 000 users
870 000 events	5 additional inputs	3 additional outputs	EMM/HID card format

Application

KT08.3A IP-Stile is a ready-for-use access control system based on a tripod turnstile. The IP-Stile features:

- IP-Stile housing with built-in controller and two proximity readers
- RC-panel (buttons orientation is to be set upon connecting the panel)
- Software



RC-panel

The IP-Stile can operate:

- as a standalone unit – local software or Web-interface allow assigning cards and checking the events log; operation from RC-panel is available.
- as a part of PERCo ACS – compatible with any system, operation from RC-panel is available.

Ethernet (supports the TCP/IP (ARP, IP, ICMP, TCP, UDP, DHCP protocol stack) is the connection interface with a computer and other controllers of the system.

In order to calculate the number of necessary IP-Stiles, it is recommended to install one turnstile per 500 people working the same shift based on the maximum working load of 30 persons/min.

KT08.3A IP-Stile is certified for compliance with applicable Russian and European CE standards.

Optional equipment

It supports the RS-485 interface connection of the following devices:

- up to 8 CL201.1 lock controllers (CL201.1 controller features a built-in reader and allows operating one lock);
- IC-05 card capture reader (for connection layout see IC-05 description)

Configuration

Through the Web-interface users are able to choose one of the following variants of the IP-Stile controller memory allocation:

- 50,000 cards and 230,000 events – set by default,
- 40,000 cards and 390,000 events,
- 30,000 cards and 550,000 events,
- 20,000 cards and 710,000 events,
- 10,000 cards and 870,000 events.



KT08.3A IP-Stile

Main features

KT08.3A IP-Stile features:

- built-in ACS controller equipped with Web-interface for the initial setting and current parameter control
- built-in proximity reader
- plastic side covers feature built-in passage grant / denial indication, and the top cover features colour dynamic LED indication
- built-in hydraulic damper
- possibility of automatic passage opening upon the command from the Fire Alarm emergency unlocking device
- optical sensors for barrier arms rotation which provide correct passages registration



LED passage indication

Design

The IP-Stile housing is made of stainless steel with ABS-plastic inserts. Barrier arms are made of stainless steel.

Operating conditions

The IP-Stile with regard to resistance to environmental exposure complies with IP54 (for outdoor sheltered application or in premises without climate control).

Operation of the IP-Stile is allowed at ambient air temperature from -20°C to +45°C (to +55°C when used under shelter) and at relative air humidity of up to 100% at +25°C.

Delivery set

Standard delivery set	
IP-Stile housing with the CT03.2 controller, built-in proximity readers and indication blocks	1
Hub with barrier arms and fastening	1
RC-panel (cable length not less than 6.6 m)	1
SW3 Allen key for the IP-Stile top cover lock	1
Mounting kit	1
Free PERCo-Web license	1
Documentation set	1
Optional equipment (upon request)	
Power supply	1
Intrusion detector	1
Siren	1
WRC kit (features a receiver and two transmitters (fobs) with operation range of up to 40 m)	1
CL201.1 lock controllers	up to 8
SORMAT PFG IR 10-15 anchor bolts	4

Technical specifications

Operating voltage	12±1.2V DC
Current consumption, max.	6.0 A
Power consumption, max.	72 W

Overall dimensions with barrier arms installed (LxWxH)	777x798x1084 mm	
Passageway width	500 mm	
Net weight, max.	40 kg	
Number of readers	2	
Proximity cards format	EMM/HID	
Card reading distance at the nominal operating voltage	6 cm	
Number of users (access cards)	from 10,000 to 50,000	
Number of events	from 230,000 to 870,000	
Communication interface standard	Ethernet (IEEE 802.3)	
Number of additional inputs	5 (1 of them is constant – Fire Alarm)	
Number of additional outputs	3	
Electric shock protection class	III (IEC 61140)	
Ingress Protection Rating	IP54 (EN 60529)	
Mean time to failure, min.	4,000,000 passages	
Mean lifetime	8 years	
Throughput rate	in the single passage mode	30 persons / min
	in the free passage mode	60 persons / min

Connection

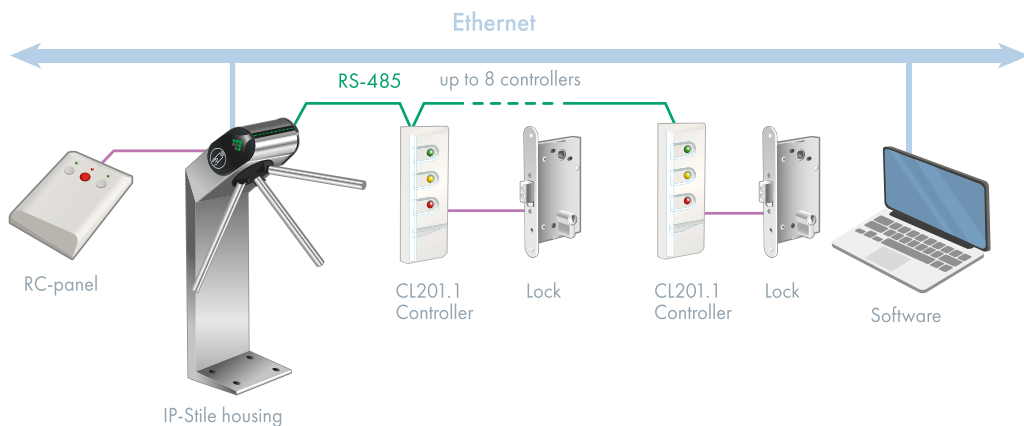

IP-Stile connection layout

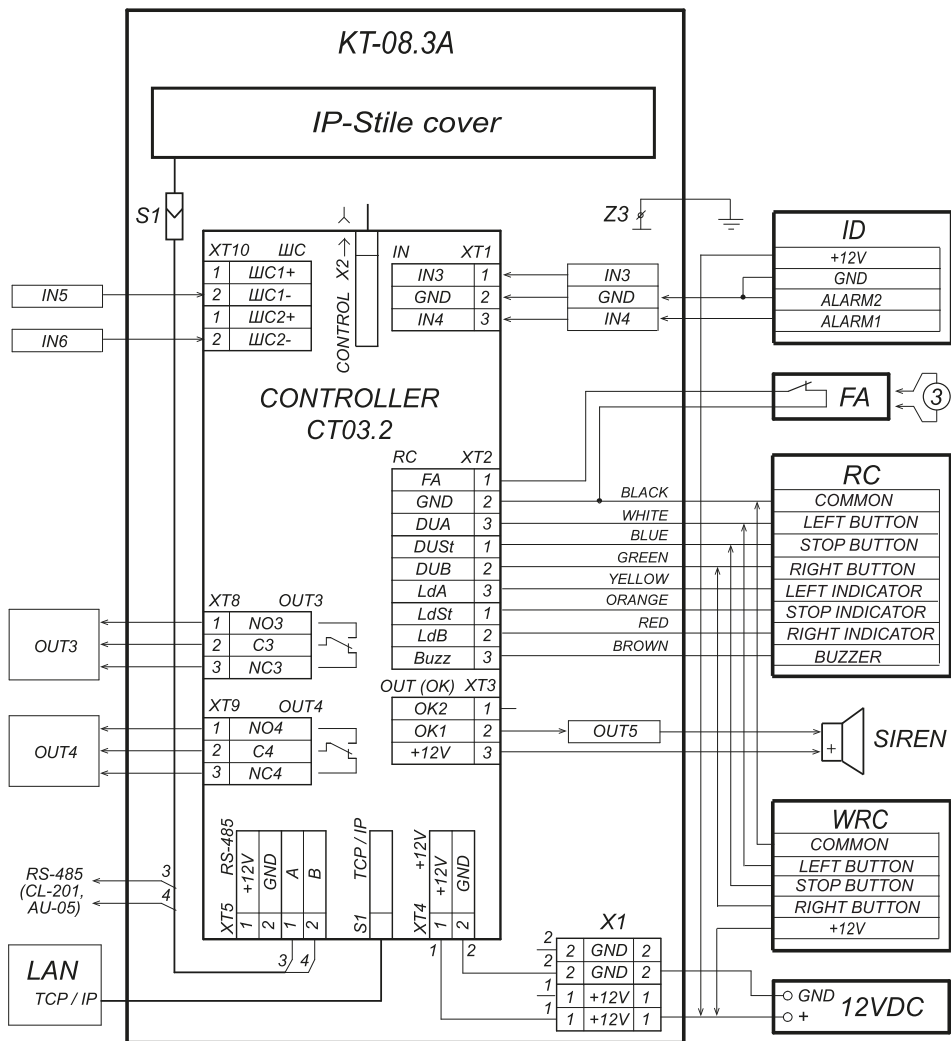

KT08.3A wiring diagram

The maximum allowed control cable length is 40 m.

The maximum allowed power cable length depends on its cross-section and shall be:

- 1.5 mm² cable cross-section – 10 m;
- 2.5 mm² cable cross-section – 15 m.

Overall dimensions

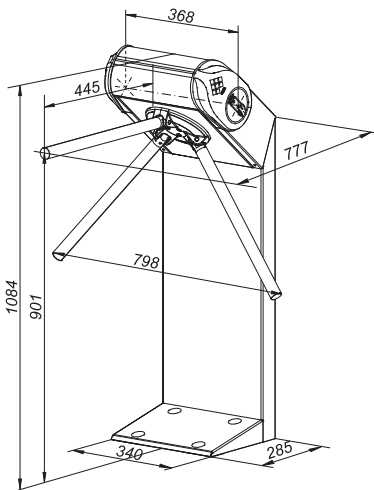

Overall dimensions

Mounting

Foundation requirements: concrete (grade 400 or higher), stone or similar foundations of at least 150 mm thick. For the installation of the IP-Stile on a less steady foundation it is recommended to apply reinforcing elements (400×400×300 mm).

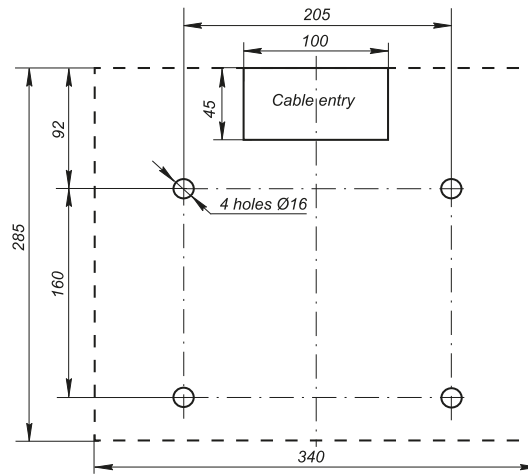

Hole marking

Passage zone modeling

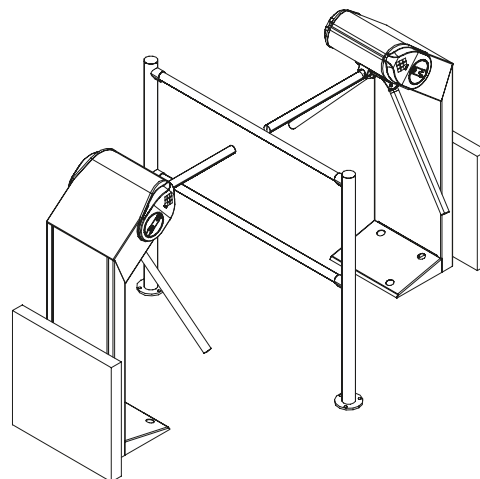

Example of an entrance zone project

Warranty

The warranty period is 5 years commencing from the date of sale if other is not stated in the contract for product delivery. In case of purchase and installation of the equipment by PERCo authorized dealers and service centers, the warranty period starts from the moment of the commissioning.

Should there be no date of sale on the warranty card, the warranty period shall commence from the date of manufacture specified in the Certificate and on the Product label.



KT02.9B IP-Stile



+50
+1
temperature range

12V
operating voltage

2
passage directions

30
persons/min

mechanical unlocking

Ethernet
interface

2
readers

50 000
users

150 000
events

8
control inputs

5
control outputs

EMM/HID/
MIFARE
card format

2
fingerprint scanners

Application

KT02.9B IP-Stile is a ready-for-use access control system based on a tripod turnstile. IP-Stile features:

- IP-Stile with built-in controller, fingerprint scanners and RFID-readers
- RC-panel (buttons orientation is to be set when connecting the panel)
- Software



RC-panel

The IP-Stile is equipped with two fingerprint scanners and two built-in RFID-readers of the following formats:

1. EMM/HID,
2. MIFARE reading:
 - either unique identifier UID, or cryptoprotected data from the internal memory of the card (additional programming of readers and cards is required)
 - UID from payment cards supporting PayPass contactless payment method
 - Android smartphones with NFC function reading unique identifier (IMSI), linked to phone's SIM-card (installation and launch of free "PERCo. Access" application is required)
 - Apple smartphones with NFC function reading unique identifier (Token), linked to a bank card if several bank cards are linked, the Token of the currently active card is scanned)

Ethernet (supports the TCP/IP (ARP, IP, ICMP, TCP, UDP, DHCP protocol stack) is a connection interface with a computer and other controllers of the system.

To calculate the number of necessary IP-Stiles it is recommended to install one turnstile per 500 people working the same shift based on a maximum working load of 30 persons/min.

KT02.9B IP-Stile is certified for compliance with applicable Russian and European CE standards.

Optional equipment

It supports the RS-485 interface connection of the following devices:

- IC-05 card capture reader (for connection layout see IC-05 description)

Main features

KT02.9B IP-Stile features:

- built-in grant / denial indication of passage and operating mode
- built-in hydraulic damper
- possibility of mechanical release with a key
- possibility of intrusion detector, siren, external verifying device and other optional equipment, also, emergency release device connection
- Web-interface integrated into the controller for IP-Stile parameters setting, management and control

Built-in reader



Indication panel with pictograms



Mechanical unlocking with a key

Design

The IP-Stile is made of powder-coated steel. The housing colour is dark grey with a pearl mica effect. The top cover and barrier arms are made of stainless steel.

The IP-Stile can be equipped with two models of the barrier arms:

barrier arms model	Barrier arms
AS-01	Standard
AA-01	With mechanical anti-panic function



Mechanical anti-panic barrier arms

Operating conditions

The IP-Stile, with regard to resistance to environmental exposure, complies with GOST 15150-69 category NF4 (operation in premises with climate control). The IP-Stile should be operated at ambient air temperature from +1°C to +50°C and relative air humidity of up to 80% at +25°C (non-condensing).

Delivery set

Standard delivery set	
KT02.9B IP-Stile housing (with CT13 controller board installed)	1
Barrier arm (model to be chosen when ordering)	3
Key to top cover lock	2
Key to mechanical release lock	2
RC-panel with cable	1
Free PERCo-Web license	1
Mounting kit	1
Documentation set	1
Optional equipment (upon request)	
Power supply	1
WRC kit (features a receiver and two transmitters (fobs)) with operation range of up to 40 m	1
Intrusion detector (installed by the manufacturer upon request)	1
Siren	1
PoE-splitter	1
SORMAT PFG IR 10-15 anchor bolts	4



Technical specifications

IP-Stiles

Operating voltage*	12±1.2V DC	
Current consumption, max.	0.8 A	
Power consumption, max.	10 W	
Overall dimensions with barrier arms installed (L×W×H)	640x683x1040 mm	
Passageway width	500 mm	
RC-panel cable length	14 m	
Net weight, max.	35 kg	
Number of users (access cards)	50,000	
Number of events	150,000	
Communication interface standard	Ethernet (IEEE 802.3)	
Number of readers	2 scanners (USB) and 4 readers (RS-485)	
Proximity cards format	EMM/HID, MIFARE Classic, Plus, Ultralight, DESFire, PayPass payment cards, smartphones with NFC function	
Card reading distance at the nominal operating voltage, min.	for EMM/HID cards	5-7 cm
	for MIFARE cards	2-6 cm
Number of additional inputs	8	
Number of additional relay outputs (NC, C, NO relay outputs)	5	
Electric shock protection class	III (IEC 61140)	
Mean time to failure, min.	4,000,000 passages	
Mean lifetime	8 years	
Throughput rate	in the single passage mode	30 persons / min
	in the free passage mode	60 persons / min
Package dimensions (L×W×H)	112x75x35 cm	

* It is recommended to use 12 VDC 2A power supply with linear stabilization of voltage and pulse amplitude at output not exceeding 50 mV.

Connection

As a standalone unit

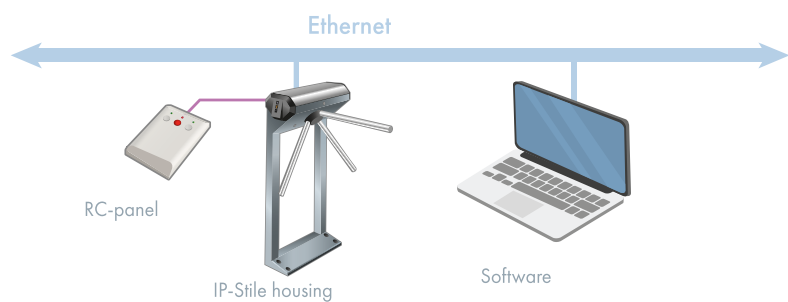

As a part of PERCo systems

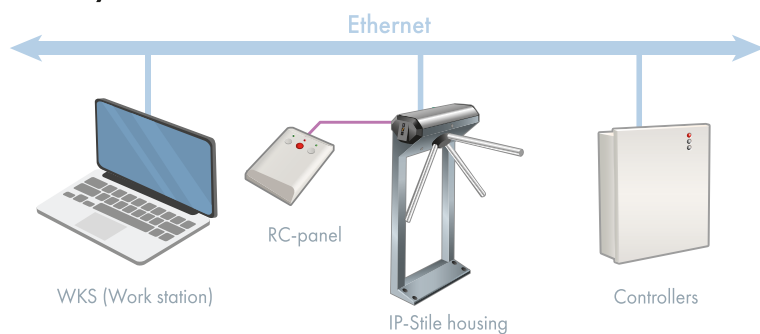

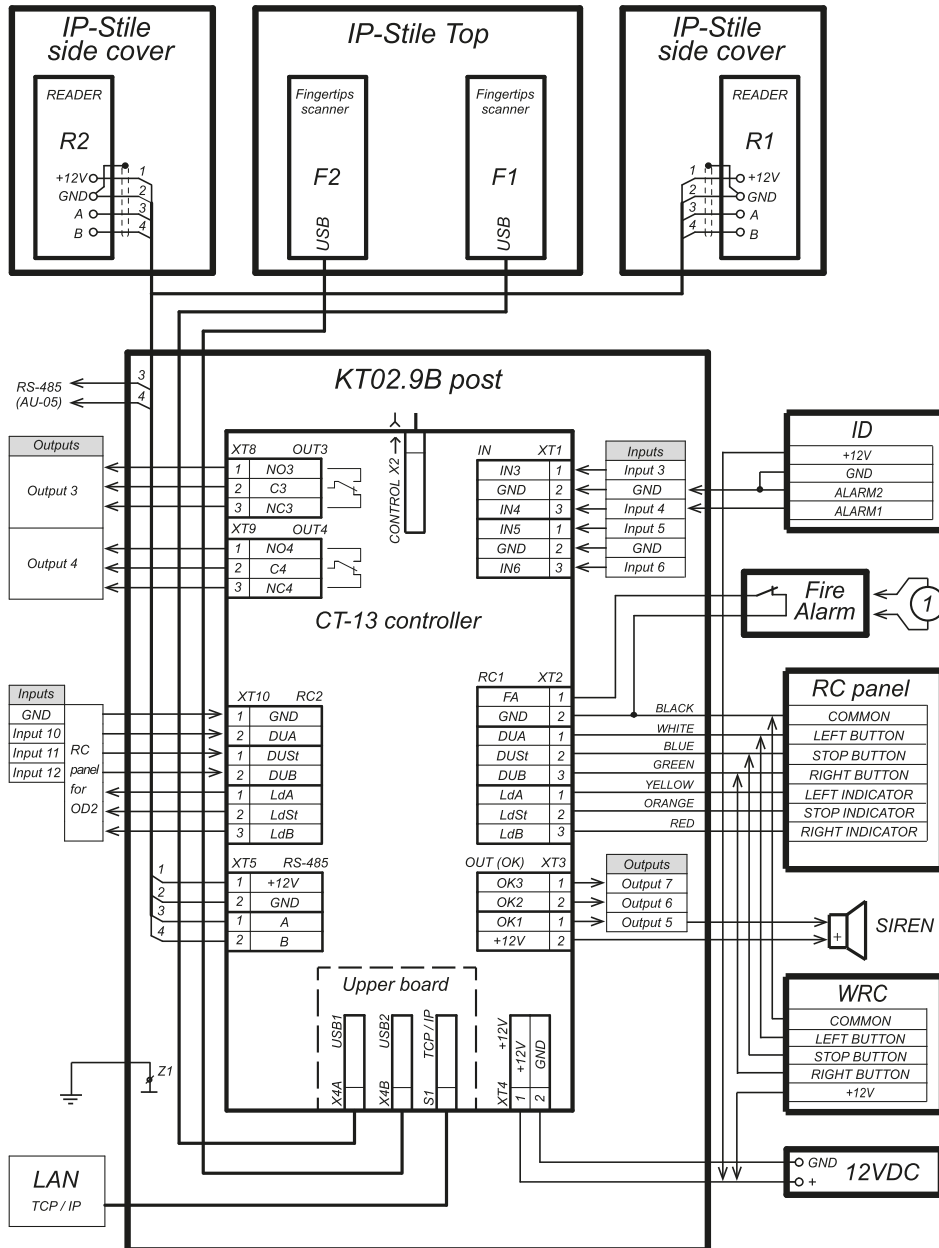

① jump wire when there is no Fire Alarm device

IP-Stile wiring diagram

The maximum allowed control cable length is 40 m. Recommended cable type is CQR CABS8 (8x0.22c).

The maximum allowed power cable length depends on its cross-section and shall be:

- 0.75 mm² cable cross-section – 10 m;
- 1.5 mm² cable cross-section – 30 m. Recommended cable type is 2x0.75 power cable.



Power supply connection via POE splitter PA 1212

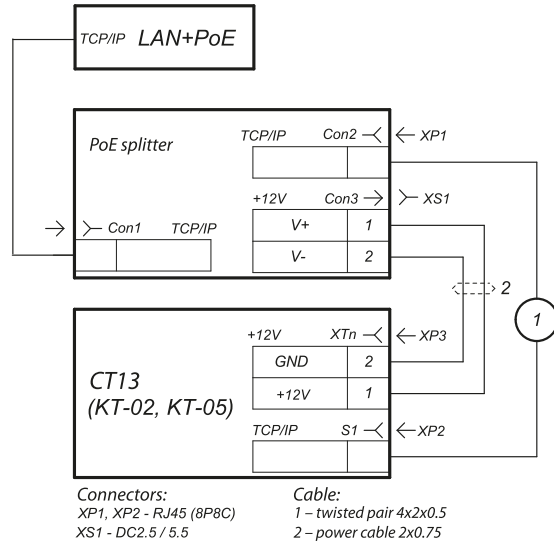

IP-Stile controller connection

Overall dimensions

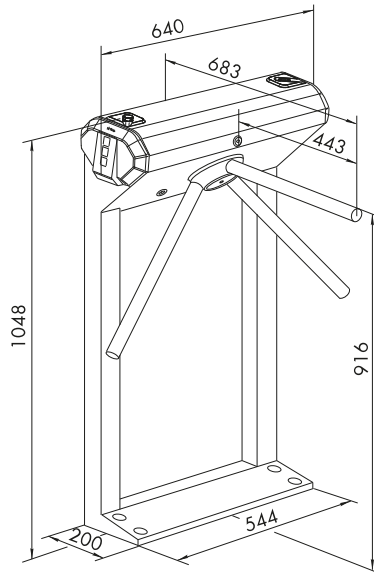

Overall dimensions

Mounting

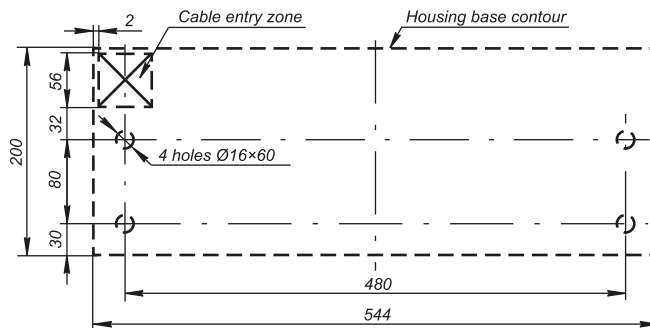

Hole layout

Foundation requirements: concrete (grade 400 or higher), stone or similar foundations of at least 150 mm thick. For the installation of the IP-Stile on a less steady foundation it is recommended to apply reinforcing elements (550x550x200 mm).

Passage zone modeling

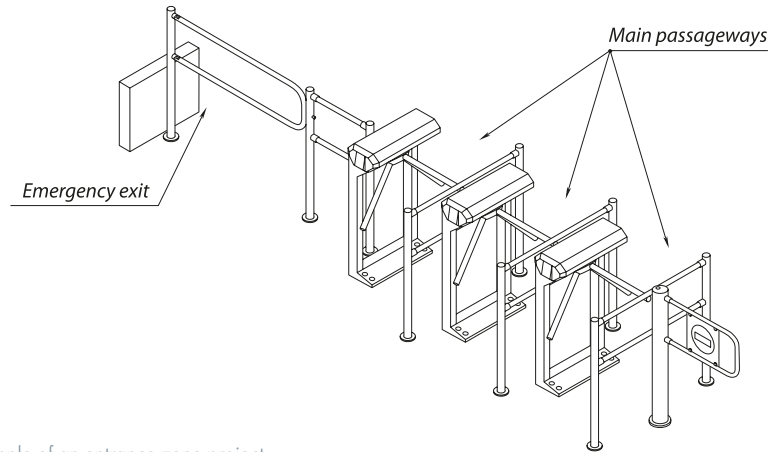

Example of an entrance zone project

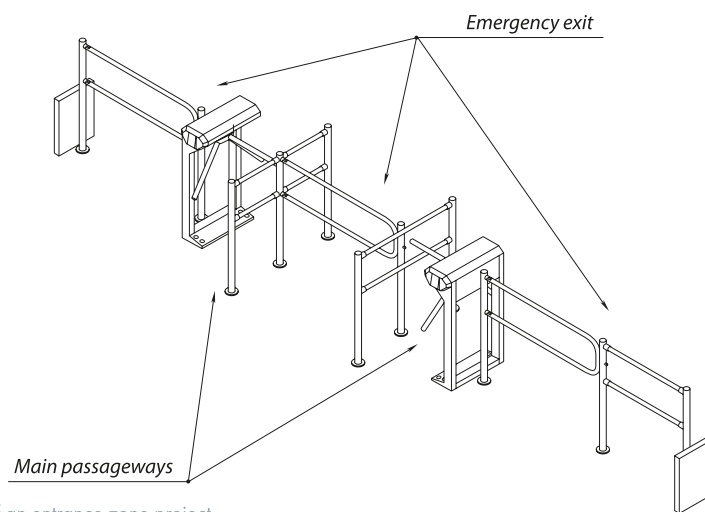

Example of an entrance zone project

Warranty

The warranty period is 5 years commencing from the date of sale if other is not stated in the contract for product delivery. In case of purchase and installation of the equipment by PERCo authorized dealers and service centers, the warranty period starts from the moment of the commissioning.

Should there be no date of sale on the warranty card, the warranty period shall commence from the date of manufacture specified in the Certificate and on the Product label.



KT02.9 IP-Stile



+50
+1
temperature range

12V
operating voltage

2
passage directions

30
persons/min

mechanical unlocking

Ethernet
interface

2
readers

50 000
users

870 000
events

5
additional outputs

4
additional inputs

EMM/HID/
MIFARE
card format

Application

KT02.9 IP-Stile is a ready-for-use access control system based on a tripod turnstile. The IP-Stile features:

- IP-Stile housing with a built-in controller and two proximity readers
- RC-panel (buttons orientation is to be set upon connecting the panel)
- Software



RC-panel

The IP-Stile can operate:

- as a standalone unit – local software or Web-interface allow assigning cards and checking the events log; operation from RC-panel and WRC is available
- as a part of PERCo-Web ACS: all system characteristics are available; operation from RC-panel and WRC is available

IP-Stile is equipped with readers of the following formats:

1. EMM/HID,
2. MIFARE reading:
 - either unique identifier UID, or cryptoprotected data from the internal memory of the card (additional programming of readers and cards is required)
 - UID from payment cards supporting PayPass contactless payment method
 - Android smartphones with NFC function reading unique identifier (IMSI), linked to phone's SIM-card (installation and launch of free "PERCo. Access" application is required)
 - Apple smartphones with NFC function reading unique identifier (Token), linked to a bank card if several bank cards are linked, the Token of the currently active card is scanned

Ethernet (supports the TCP/IP (ARP, IP, ICMP, TCP, UDP, DHCP protocol stack) is a connection interface with a computer and other controllers of the system.

To calculate the number of necessary IP-Stiles it is recommended to install one turnstile per 500 people working the same shift and based on a maximum working load of 30 persons/min.

KT02.9 IP-Stile is a serially produced product certified for compliance with applicable Russian and European CE standards.

Optional equipment

It supports the RS-485 interface connection of the following devices:

- up to 8 CL201.1 lock controllers (CL201.1 controller has a built-in EMM/HID reader and provides control of one lock)
- IC-05 card capture reader (for connection layout see IC-05 description)

Configuration

Through the Web-interface users are able to choose one of the following variants of the IP-Stile controller memory allocation:

- 50,000 cards and 230,000 events – set by default,
- 40,000 cards and 390,000 events,
- 30,000 cards and 550,000 events,
- 20,000 cards and 710,000 events,
- 10,000 cards and 870,000 events.

Main features

KT02.9 IP-Stile features:

- built-in grant / denial indication of passage and operating mode
- built-in hydraulic damper
- possibility of mechanical release with a key
- possibility of intrusion detector, siren and other optional equipment, also, emergency release device connection
- Web-interface integrated into the controller for initial setting and current parameter control

Built-in reader



Pictogram indication block



Mechanical release lock

Design

The IP-Stile is made of powder-coated steel. The housing colour is dark grey with a pearl mica effect.

The top cover and barrier arms are made of stainless steel.

The IP-Stile can be equipped with two models of barrier arms:

Barrier arms model	Barrier arms
AS-01	Standard
AA-01	With mechanical anti-panic function



Mechanical anti-panic barrier arms

Operating conditions

The IP-Stile, with regard to resistance to environmental exposure, complies with GOST 15150-69 category NF4 (operation in premises with climate control). The IP-Stile should be operated at ambient air temperature from +1 °C to + 50 °C and relative air humidity of up to 80% at +25 °C (non-condensing).

Delivery set

Standard delivery set	
KT02.9 IP-Stile housing (with CT03.2 controller board installed)	1
Barrier arm (model to be chosen when ordering)	3
Key to top cover lock	2
Key to mechanical release lock	2
RC-panel with cable	1
Mounting kit	1
Documentation set	1



Technical specifications

Optional equipment (upon request)	
Power supply	1
WRC kit (features a receiver and two transmitters (fobs)) with operation range of up to 40 m	1
Intrusion detector (installed by the manufacturer upon request)	1
Siren	1
CL201.1 lock controllers	up to 8
PoE-splitter	1
SORMAT PFG IR 10-15 anchor bolts	4

Operating voltage*	12±1.2V DC	
Current consumption, max.	0.8 A	
Power consumption, max.	10 W	
Overall dimensions with barrier arms installed (L×W×H)	640×683×1040 mm	
Passageway width	500 mm	
RC-panel cable length	14 m	
Net weight, max.	35 kg	
Number of users (access cards)	from 10,000 to 50,000	
Number of events	from 230,000 to 870,000	
Communication interface standard	Ethernet (IEEE 802.3)	
Number of readers	2	
Proximity cards format	EMM, HID, Mifare	
Card reading distance at the nominal operating voltage, min.	for EMM/HID cards	5-7 cm
	for MIFARE cards	3-6 cm
Number of additional inputs	5	
Number of additional relay outputs (NC, C, NO relay outputs)	4	
Electric shock protection class	III (IEC 61140)	
Ingress Protection Rating	IP41 (EN 60529)	
Mean time to failure, min.	4,000,000	
Mean lifetime	8 years	
Throughput rate	in the single passage mode	30 persons / min
	in the free passage mode	60 persons / min
Package dimensions (L×W×H)	112×75×35 cm	

* It is recommended to use 12 VDC 2A power supply with linear stabilization of voltage and pulse amplitude at output not exceeding 50 mV.

Connection

As a standalone unit

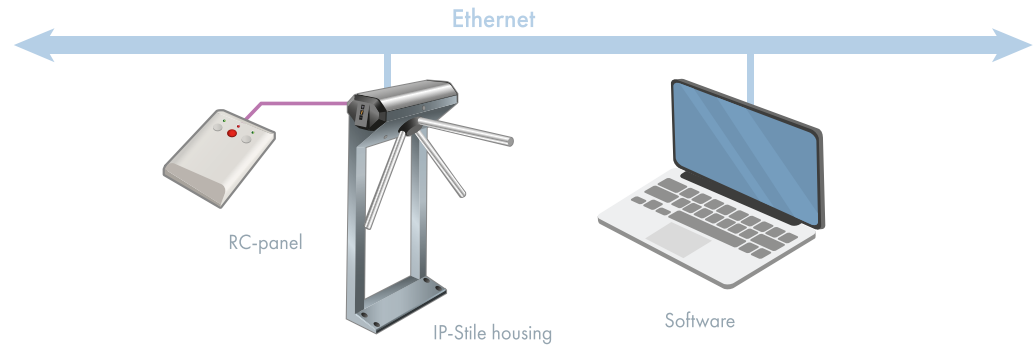

As a part of PERCo system

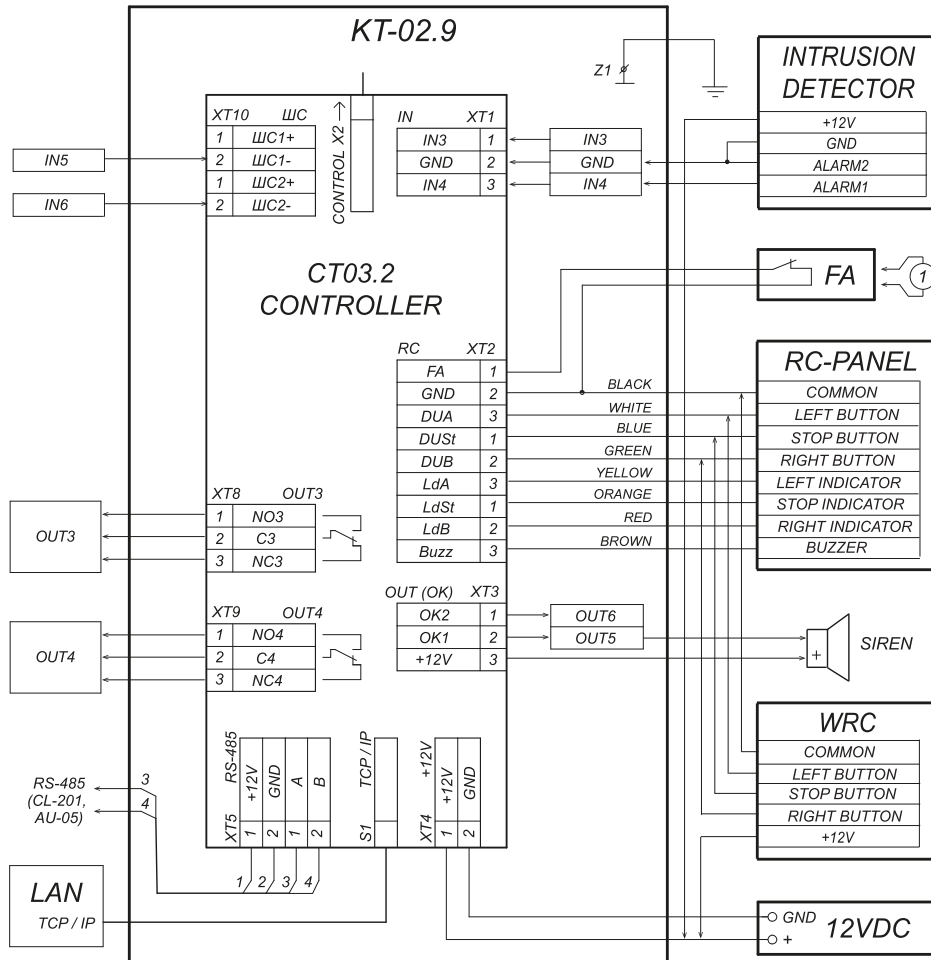
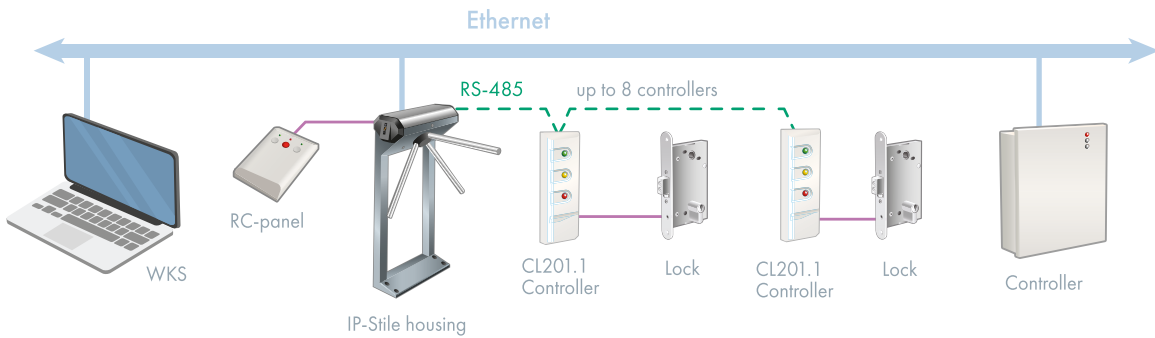

1 - Jumper wire when there is no fire alarm device

Wiring diagram of external equipment connection to the built-in controller board



The maximum allowed power cable length depends on its cross-section and shall be:

- 0.75 mm² cable cross-section – 10 m;
- 1.5 mm² cable cross-section – 30 m. Recommended cable type is 2x0.75 power cable.

Power supply connection via POE splitter PA 1212

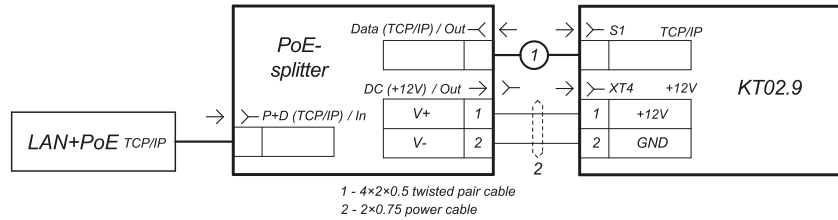

IP-Stile controller connection

Overall dimensions

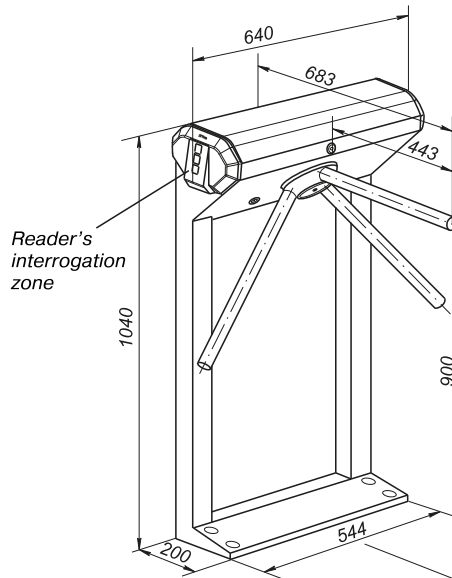

Overall dimensions

Mounting

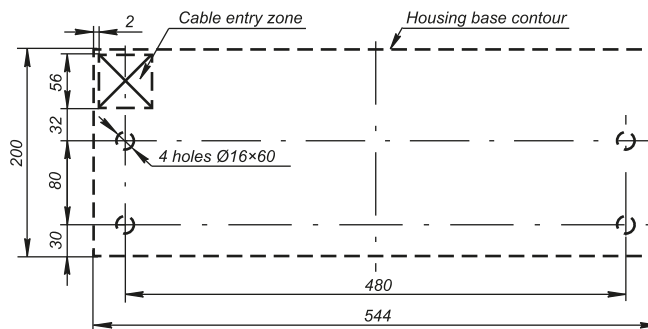

Hole layout

Foundation requirements: concrete (grade 400 or higher), stone or similar foundations of at least 150 mm thick. For the installation of the IP-Stile on a less steady foundation it is recommended to apply reinforcing elements (550x550x200 mm).

Passage zone modeling

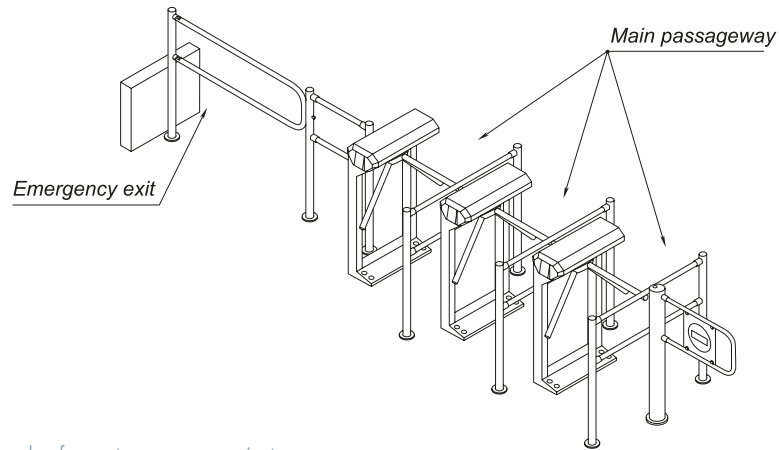

Example of an entrance zone project

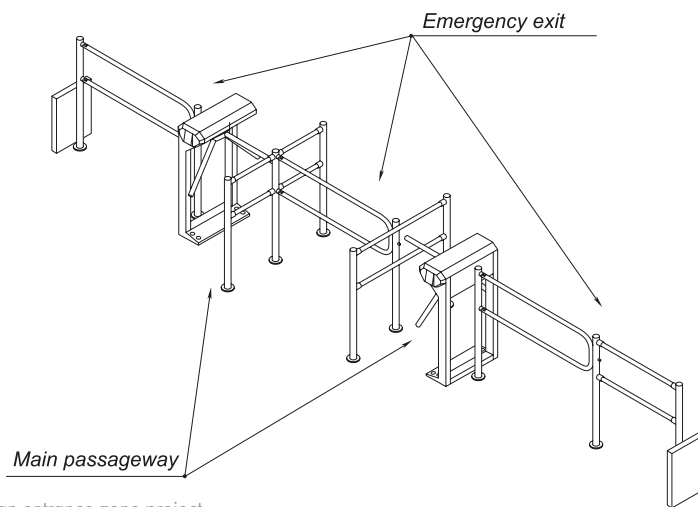

Example of an entrance zone project

Warranty

The warranty period is 5 years commencing from the date of sale if other is not stated in the contract for product delivery. In case of purchase and installation of the equipment by PERCo authorized dealers and service centers, the warranty period starts from the moment of the commissioning.

Should there be no date of sale on the warranty card, the warranty period shall commence from the date of manufacture specified in the Certificate and on the Product label.



KT05.9A IP-Stile

IP-Stiles



+50 -1 temperature range	12V operating voltage	2 passage directions	30 persons/min
anti-panic barrier arms	Ethernet interface	2 readers	50 000 users
870 000 events	5 additional inputs	3 additional outputs	72W power consumption
EMM/HID/ MIFARE card format			

Application

KT05.9A IP-Stile is a ready-for-use access control system based on a box tripod turnstile with automatic anti-panic barrier arms.

The IP-Stile features:

- IP-Stile housing with a built-in controller and two proximity readers
- RC-panel (buttons orientation is to be set upon connecting the panel)
- Software

The IP-Stile can operate:

- as a standalone unit – local software or Web-interface allow assigning cards and checking the events log; operation from RC-panel and WRC is available
- as a part of PERCo-Web ACS: all system characteristics are available; operation from RC-panel and WRC is available



Automatic anti-panic barrier arms



RC-panel

The IP-Stile is equipped with readers of the following formats:

1. EMM/HID,

2. MIFARE reading:

- either unique identifier UID, or cryptoprotected data from the internal memory of the card (additional programming of readers and cards is required)
- UID from payment cards supporting PayPass contactless payment method
- Android smartphones with NFC function reading unique identifier (IMSI), linked to phone's SIM-card (installation and launch of free "PERCo. Access" application is required)
- Apple smartphones with NFC function reading unique identifier (Token), linked to a bank card if several bank cards are linked, the Token of the currently active card is scanned)

Ethernet (supports the TCP/IP (ARP, IP, ICMP, TCP, UDP, DHCP protocol stack) is a connection interface with a computer and other controllers of the system.

To calculate the number of necessary IP-Stiles it is recommended to install one turnstile per 500 people working the same shift and based on a maximum working load of 30 persons/min.

KT05.9A IP-Stile is a serially produced product certified for compliance with applicable Russian and European CE standards.

Optional equipment

It supports the RS-485 interface connection of the following devices:

- up to 8 CL201.1 lock controllers (CL201.1 controller has a built-in EMM/HID reader and provides controlling one lock)
- IC-05 card capture reader (for connection layout see IC-05 description)

Configuration

Through the Web-interface users are able to choose one of the following variants of the IP-Stile controller memory allocation:

- 50,000 cards and 230,000 events – set by default,
- 40,000 cards and 390,000 events,
- 30,000 cards and 550,000 events,
- 20,000 cards and 710,000 events,
- 10,000 cards and 870,000 events.

Main features

KT05.9A IP-Stile features:

- built-in grant / denial indication of passage and operating mode
- built-in hydraulic damper
- automatic opening from Fire Alarm emergency unlocking device by moving the barrier arms to vertical position
- possibility of intrusion detector, siren and other optional equipment, also, emergency release device connection
- Web-interface integrated into the controller for initial setting and current parameter control

Built-in reader

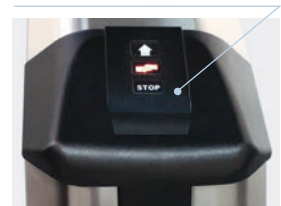

Pictogram indication block

Design

The IP-Stile is made of powder-coated steel. The housing colour is dark grey with a pearl mica effect. The top cover and barrier arms are made of stainless steel.

Operating conditions

The IP-Stile, with regard to resistance to environmental exposure, complies with GOST 15150-69 category NF4 (operation in premises with climate control). The IP-Stile should be operated at ambient air temperature from +1 °C to + 50°C and relative air humidity of up to 80% at +25°C (non-condensing).

Delivery set

Standard delivery set	
KT05.9A IP-Stile housing (with CT03.2 controller board installed)	1
Barrier arm (model to be chosen when ordering)	3
SW2.5 Allen key for turnstile cover lock	1
RC-panel with cable	1
Mounting kit	1
Documentation set	1
Optional equipment (upon request)	
Power supply	1
WRC kit (features a receiver and two transmitters (fobs)) with operation range of up to 40 m	1
Intrusion detector (installed by the manufacturer upon request)	1
Siren	1
CL201.1 lock controllers	up to 8
PoE-splitter	1
SORMAT PFG IR 10-15 anchor bolts	4



KT05.9A IP-Stile

Technical specifications

Operating voltage*	12±1.2V DC	
Current consumption, max.	6.0 A	
Power consumption, max.	72 W	
Overall dimensions with barrier arms installed (L×W×H)	1170×750×1030 mm	
Passageway width	560 mm	
RC-panel cable length	6.6 m	
Net weight, max.	68 kg	
Number of users (access cards)	from 10,000 to 50,000	
Number of events	from 230,000 to 870,000	
Communication interface standard	Ethernet (IEEE 802.3)	
Number of readers	2	
Proximity cards format	EMM, HID, Mifare, PayPass, NFC (smartphones)	
Card reading distance at the nominal operating voltage, min.	for EMM/HID cards	5-7 cm
	for MIFARE cards, smartphones with NFC	3-6 cm
Number of additional inputs	4	
Number of additional relay outputs (NC, C, NO relay outputs)	3	
Electric shock protection class	III (IEC 61140)	
Ingress Protection Rating	IP41 (EN 60529)	
Mean time to failure, min.	4,000,000	
Mean lifetime	8 years	
	Throughput rate	
	in the single passage mode	30 persons / min
	in the free passage mode	60 persons / min
Package dimensions (L×W×H)	132x110x40 cm	

Connection

As a standalone unit

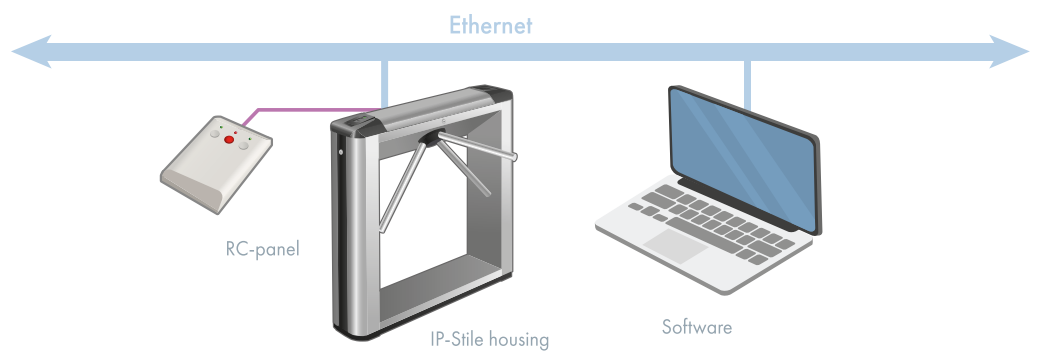

As a part of PERCo system

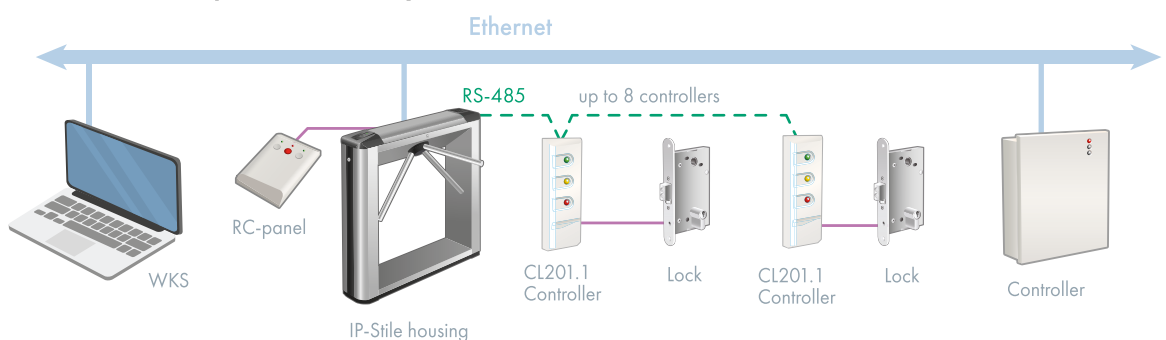

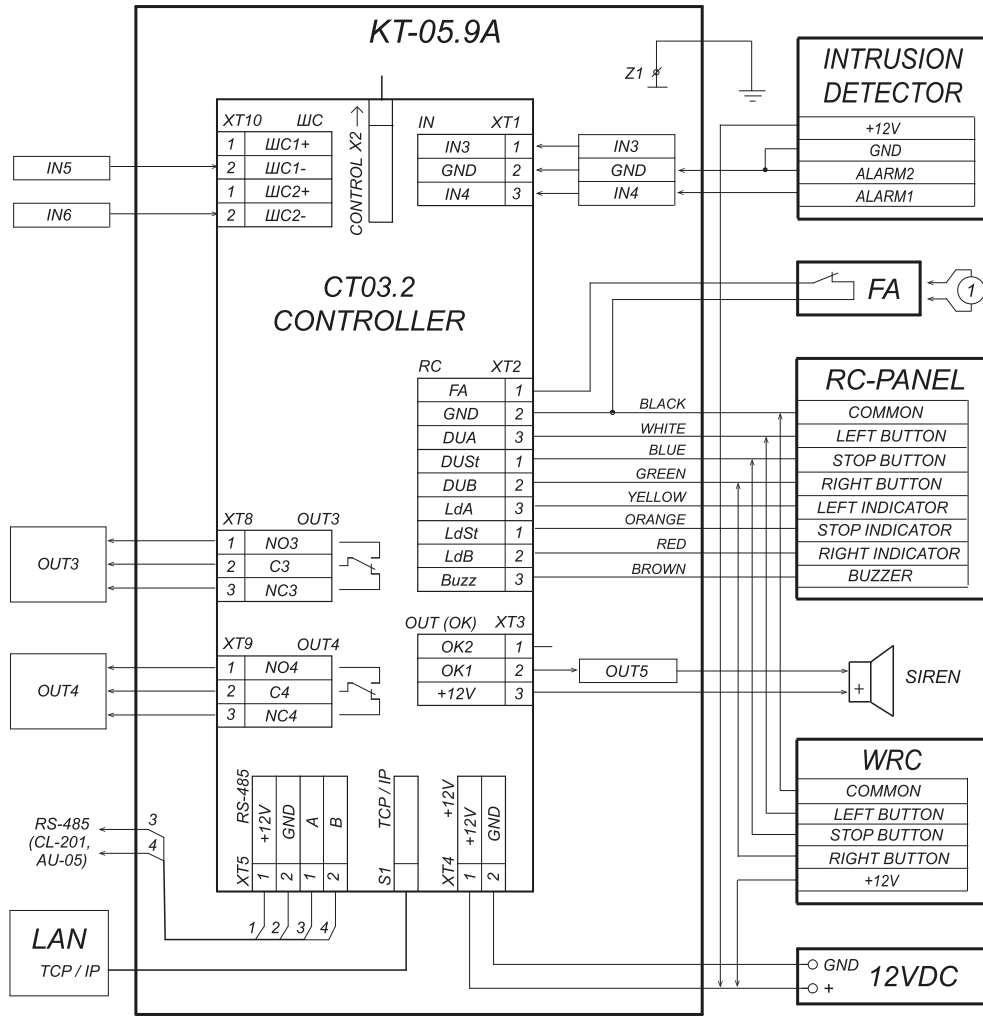

1 - Jumper wire when there is no fire alarm device

Wiring diagram of external equipment connection to the built-in controller board

The maximum allowed power cable length depends on its cross-section and shall be:

- 0.75 mm² cable cross-section – 10 m;
- 1.5 mm² cable cross-section – 30 m. Recommended cable type is 2x0.75 power cable.

Overall dimensions

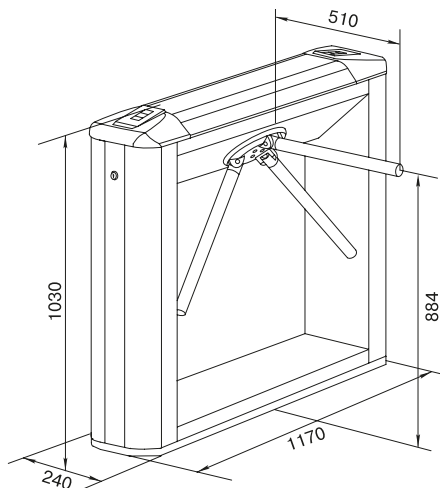

Overall dimensions



Mounting

Foundation requirements: concrete (grade 400 or higher), stone or similar foundations of at least 150 mm thick. For the installation of the IP-Stile on a less steady foundation it is recommended to apply reinforcing elements (550×550×200 mm).

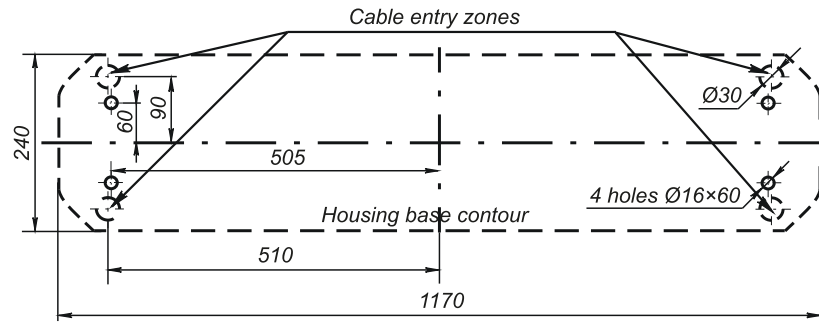

Hole marking layout

Passage zone modeling

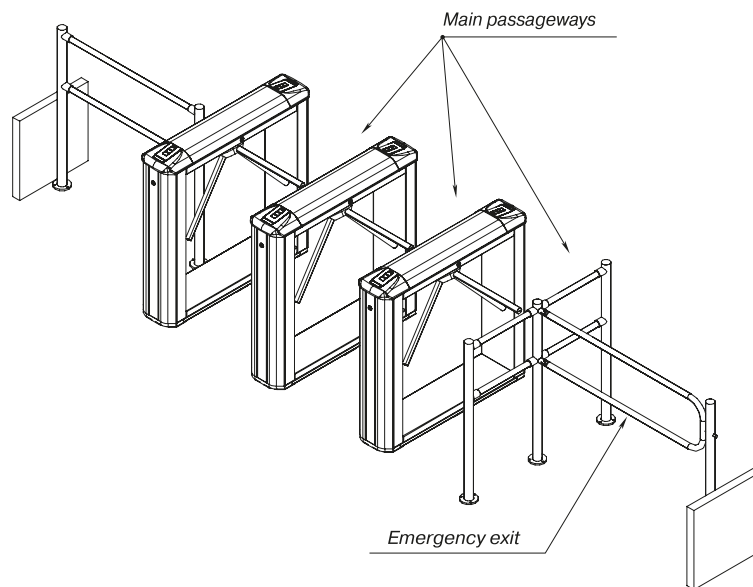

Example of an entrance zone project

Warranty

The warranty period is 5 years commencing from the date of sale if other is not stated in the contract for product delivery. In case of purchase and installation of the equipment by PERCo authorized dealers and service centers, the warranty period starts from the moment of the commissioning



+40
+1
temperature range

12V
operating voltage

RS-485
interface

Wiegand
interface

EMM/HID
card format

Application

IRP-01 post with built-in proximity reader and LCD display is designed to read and decode the access card identifier and transfer it to the ACS-controller. IRP-01 reader post is recommended to be installed at sites with high requirements for design and comfort. It is designed to be used indoors. IRP-01 reader post is a serially produced product and is certified for compliance with applicable Russian and European CE standards.

Functionality

The reader provides code reading from Proximity identifiers with operating frequency of 125 kHz produced by HID Corporation, type: ProxCard II and ISOProx II (HID standard formats: 26-bit (H10301), 37-bit (H10302, H10304)) and also identifiers produced by EM Microelectronic-Marin SA. Connection interface with the ACS-controller is RS-485 or Wiegand. Reader housing consists of a stainless steel tubular post on the top of which a reader board and LCD display are mounted. The delivery set includes a post mounting foundation to mount the reader post on the mounting surface. The reader comes with a sound indication. Code reading is confirmed by the signal going on shortly.

Operating conditions

The reader post, with regard to resistance to environmental exposure, complies with GOST 15150-69 category NF4 (operation in premises with climate control). Operation of the reader post is allowed at ambient air temperature from +1 °C to +40 °C and relative air humidity up to 80% at +25 °C.

Delivery set

Reader post	1
Foundation	1
Mounting kit	1
Documentation set	1
Optional equipment (upon request)	
SORMAT PFG IR 8-20 anchor bolts	4



IRP-01 Reader post

Technical specifications

Rated operating voltage*	12 V DC	
Operating voltage limits	10.8-14 V DC	
Current consumption	max. 150 mA	
Power consumption	max. 2 W	
Overall dimensions	1025x107x107 mm	
Reading distance	for EMM cards	min. 7 cm
	for HID cards	min. 6 cm
Connection interface**	485, Wiegand	
Distance between the reader and external controller	max. 40 m	
Mean lifetime	8 years	
Reader post weight	max. 5 kg	

* It is recommended to use power supply with linear stabilization of voltage and pulse amplitude at output not exceeding 50 mV.

** Depends on the position of the tumbler #1 in SA1 DIP-switch.

Controller operating modes indication



Control



Open



Closed



Verification process

Connection

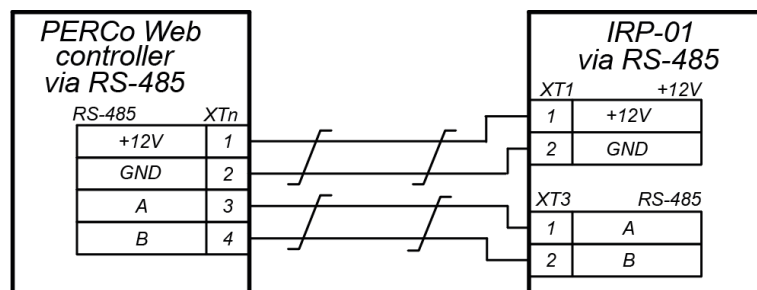

Connection of the reader to PERCo system controller via RS-485 interface

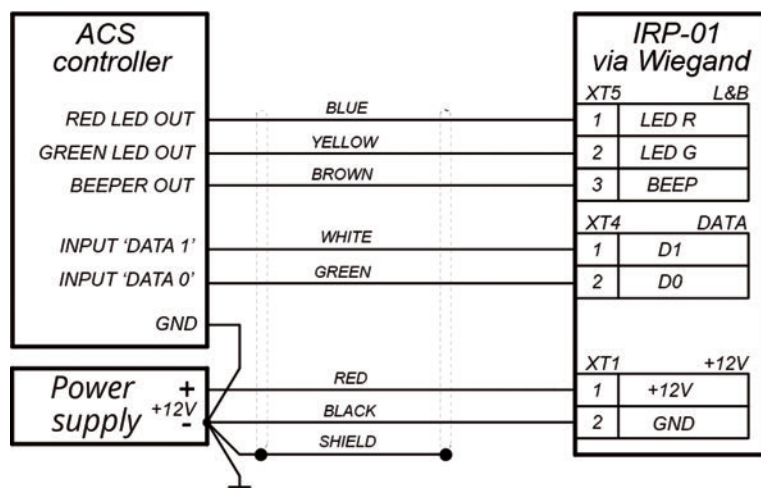

Connection of the reader to ACS-controller via Wiegand interface

The interface is to be chosen with tumbler #1 in SA1 DIP-switch, located on the reader board:

- ON - connection to RS-485 interface
- OFF - connection to Wiegand interface

Via RS-485 interface

Connection via the RS-485 interface of the reader to the controller is to be carried out using F/UTP2-Cat5e twisted pair, and the A and B signal lines are to be in one twisted pair.

When connected via RS-485, the reader operates according to the protocol of the connection of the readers in the PERCo system and can be used as an external reader for PERCo system controllers.

Setting the reader number on the SA1 DIP-switch		
Reader number	Tumbler	
	Nº1	Nº2
Reader #1	ON	ON
Reader #2	ON	OFF

End-of-line resistor connection	
End-of-line resistor	Jumper #5
connected	installed
disconnected	removed

Via Wiegand interface

Connection via Wiegand interface of the reader to the controller is to be carried out by using CABS8/EC, 8C.SEC-SC shielded cable with 24AWG–18AWG cross-section (0.2 - 0.8 mm²). Kindly note, the use of twisted cables is not allowed.

Reader indication setting on the SA1 DIP-switch		
Indication	Tumbler	
	Nº1	Nº2
"double line"	OFF	ON
"single line"	OFF	OFF

Reader indication in Wiegand mode			
Signal level on control line		Reader indication	
Led R	Led G	"double line"	"single line"
0	0	Waiting for card presentation (Hand with a card)	Access granted (moving green arrow)
0	HZ	Access granted (moving green arrow)	
HZ	0	Access denied (STOP inscription)	Access denied (STOP inscription)
HZ	HZ	Waiting for card presentation (Hand with a card)	

0 - the control line is connected to the power supply negative terminal.

HZ – high resistance on the control line (the line is not connected to the power supply negative terminal).

Reader output data format setting on the SA1 DIP-switch			
Reader output data format	Tumbler		
	Nº1	Nº2	Nº3
Wiegand 26	OFF	ON	ON
Wiegand 37	OFF	ON	OFF
Wiegand 42	OFF	OFF	ON
Wiegand	OFF	OFF	OFF



IRP-01 Reader post

Overall dimensions

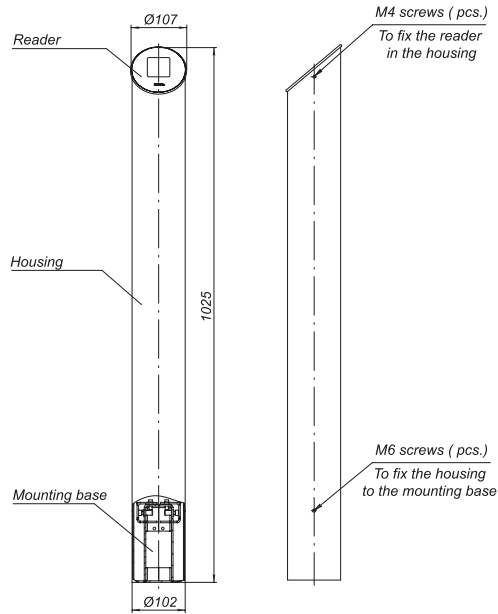

Overall dimensions

Mounting

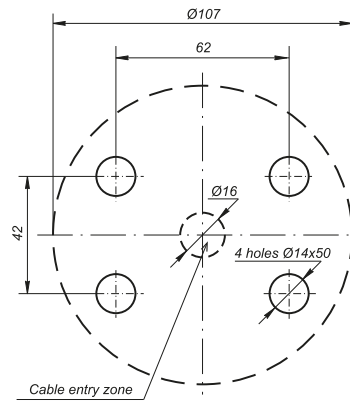

Hole marking for reader post installation

Warranty

The warranty period is 5 years commencing from the date of sale if other is not stated in the contract for product delivery. In case of purchase and installation of the equipment by PERCO authorized dealers and service centers, the warranty period starts from the moment of the commissioning.

Should there be no date of sale on the warranty card, the warranty period shall commence from the date of manufacture specified in the Certificate and on the Product label



+55
+1
temperature
range

12V
operating
voltage

Application

IC-05 Card capture reader is designed to operate as a part of ACS as a reading and card capture device.

The card capture reader is to be connected to the ACS-controller. The reader is to be chosen by the Customer and installed when mounting.

The card capture reader can operate both as a part of the PERCo access control system and together with third-party controllers.

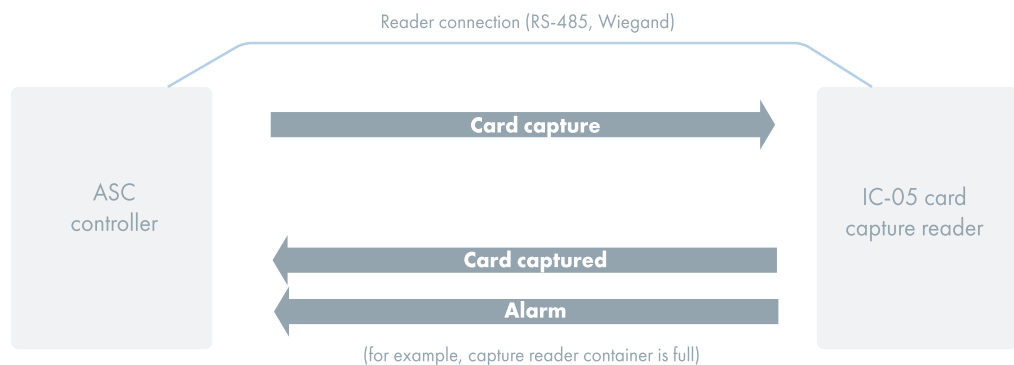

Functionality

- possibility to install any reader which allows operating with all formats of proximity cards (a reader is to be purchased for card capture reader operation)
- reading the identifier from the card inserted into the card capture reader slot
- capturing temporary visitor cards upon receipt of the command from ACS-controller
- reading permanent employee cards and transferring it to the ACS-controller
- optical sensors to control card capturing and filling of the container
- protective shutter to receive cards which prevents foreign objects from falling into the container and also cards that should not be withdrawn
- card capture slot form that allows withdrawing cards with the standard clips for badges
- indication block built into the card capture reader top cover indicating operating modes of the ACS-controller with two variants of passage directions indication (on the left or on the right of card capture reader)
- LED backlight of the card capture slot



IC-05 Card capture reader

- easy access to the container from the front side of the card capture reader, container is locked with a key
- safe operating voltage and low power consumption
- housing is made of stainless steel and ABS-plastic



Pictogram indication block



Easy access to the card container

Operating conditions

The card capture reader, with regard to resistance to environmental exposure complies with GOST 15150-69 category NF4 (operation in premises with climate control).

The card capture reader should be operated at ambient air temperature from +1 °C to +55 °C and at relative air humidity of up to 70% at +27 °C.

Delivery set

Card capture reader	1
Key to the container	2
Mounting hardware (set)	1
Technical documentation (set)	1
Optional equipment (upon request)	
SORMAT PFG IR 10 anchor bolt	4
SW8 Allen key (for M10 bolts)	1

Operating condition

Operating voltage	12±1.2 VDC	
Current consumption*	max. 1.8 A	
Power consumption	max. 22 W	
Container capacity	350 cards	
Technical specifications of the built-in reader:	overall dimensions (L×W×H)	max. 145×50×28 mm
	identifier reading range	min. 40 mm
Mean time to failure	min. 1,000,000 captures	
Mean lifetime	8 years	
Electric shock protection class	III	
Ingress Protection Rating	IP41	
Overall dimensions	197×157×990 mm	
Card capture reader weight	max. 15 kg	
Package overall dimensions	112×23×28 cm	
Gross weight	max. 23 kg	

* Power supply should provide current reserve of not less than 30%.

** Recommended cable types:

- power cable - AWG 18; HO3W-F 2×0.75 bi-colored,

- RS-485 bus - 2×2×0.52 F/UTP2-Cat5e,

- control cables and Wiegand bus - RAMCRO SA82BI-T, CABS8/EC, W8ekw 24AWG – 18AWG (0.2 - 0.8 mm²)

Connection

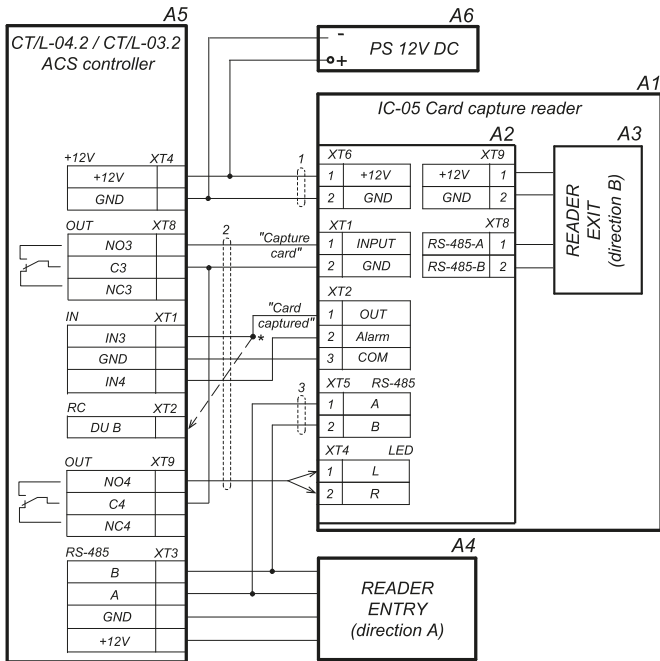

* If all additional inputs of the controller are occupied, then the "Card captured" output is connected parallel with the RC-panel to the input of the controller "DU B" (or "DU A", depending on the direction of the passage).

Connection of the card capture reader to the CT/L-04.2, CT/L-03.2 via RS-485 interface

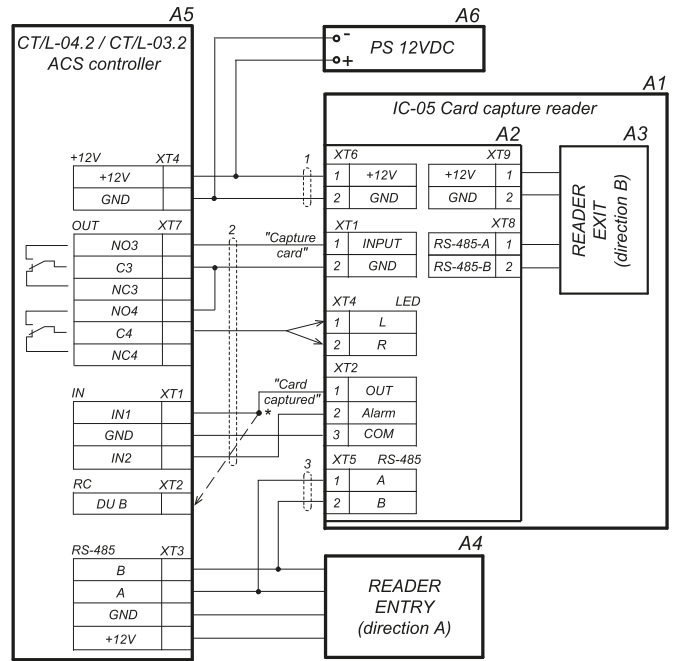

* For CT/L-04 controllers with firmware version x.0.0.19 and below, the "Card captured" output is connected in parallel with the RC-panel to the input of the controller "DU B" (or "DU A", depending on the direction of the passage). The same connection method can be used if all additional controller inputs are occupied.

Connection of the card capture reader to the CT/L-04.2, CT/L-03 via RS-485 interface

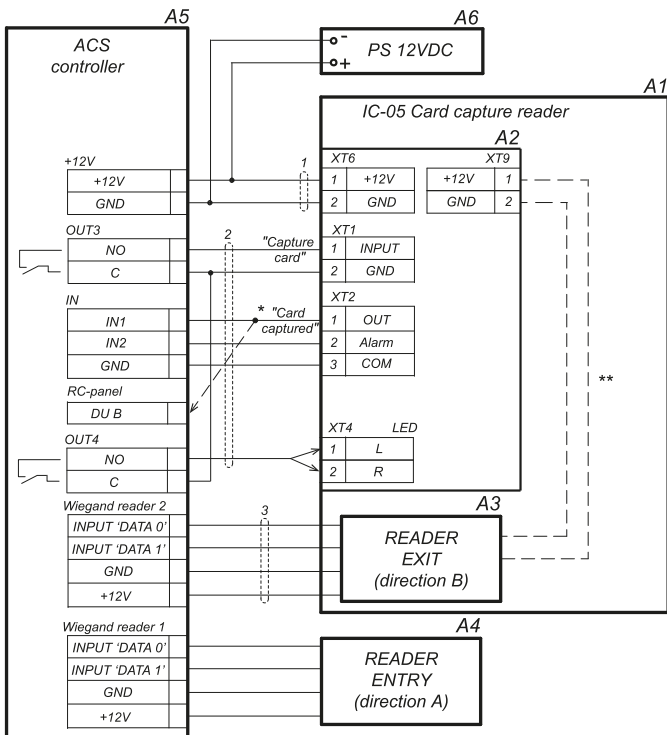

Connection of the card capture reader to the ACS controller via Wiegand interface



IC-05 Card capture reader

Card capture reader control board description	
Item	Description
A1	Card capture reader
A2	Card capture reader control board
A3*	Reader (direction B)
A4*	Reader (direction A)
A5*	ACS-controller
A6*	Power supply 12 VDC/2.5 A
1*	Card capture reader power cable
2*	ACS-controller connection cable
3*	Reader connection cable

*equipment is not included in the standard delivery set.

Control board contacts description by connectors			
Connector	Contact	Electrical circuit	Designation
XT1	INPUT	"Capture card"	Input of the control signal from ACS-controller to card capturing
	GND		
XT2	OUT	"Card captured"	Output of card capturing confirmation
	Alarm	"Failure"	Signal of container malfunction or filling
	COM		Common for "Card captured" and "Alarm" signals
XT4	L	"LED"	Activation of left green arrow
	R		Activation of right green arrow
XT5	A	"RS-485-A"	RS-485 bus to the controller
	B	"RS-485-B"	
XT6	+12V		Card capture reader power supply input
	GND		
XT8	A	"RS-485-A"	RS-485 bus to the reader
	B	"RS-485-B"	
XT9	+12V		Output of the reader power supply
	GND		

When connecting the card capture reader, proceed as follows:

- use the reader built into the card capture reader as one of the readers
- use one of the ACS-controller additional outputs for the "Capture card" signal
- use one of the additional inputs to receive the "Card captured" signal from card capture reader
- use one of the additional inputs to receive the "Alarm" signal from the card capture reader
- use one of the ACS-controller additional outputs or one of external indication output from the OD control board (turnstile, gate), if any, to control passage granting indication on the card capture reader

Overall dimensions

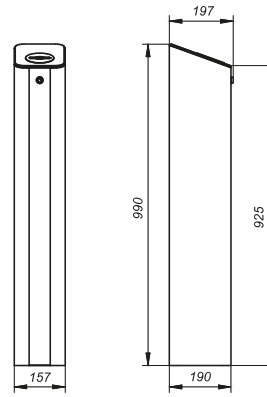

Overall dimensions

Mounting

Foundation requirements: concrete (grade 400 or higher), stone or similar foundations of at least 150 mm thick. For the installation of the card capture reader on a less steady foundation it is recommended to apply reinforcing elements (300×300×150 mm)

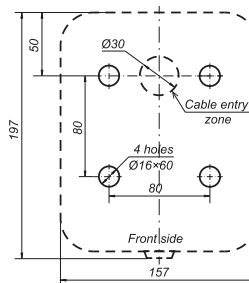

Hole marking for the card capture reader installation

Passage zone modeling

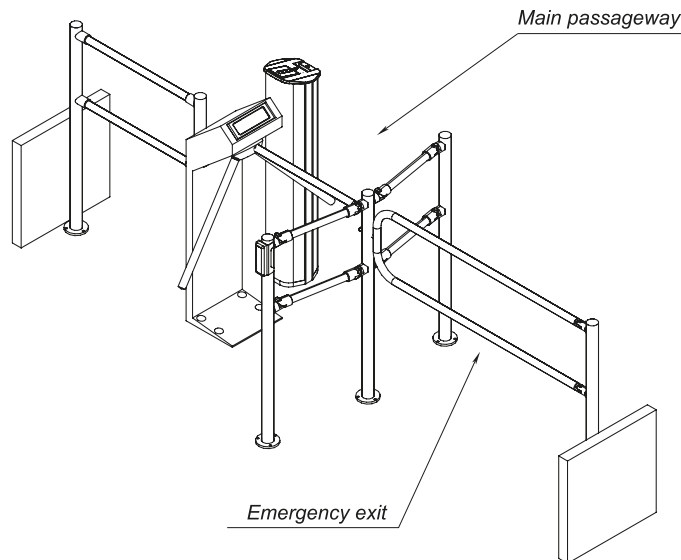

Example of an entrance zone project

Warranty

The warranty period is 5 years commencing from the date of sale if other is not stated in the contract for product delivery. In case of purchase and installation of the equipment by PERCo authorized dealers and service centers, the warranty period starts from the moment of the commissioning.

Should there be no date of sale on the warranty card, the warranty period shall commence from the date of manufacture specified in the Certificate and on the Product label.



Waist-high turnstiles and gates p. 36



- ST-11 Speed gate p. 39



- ST-02 Speed gate p. 47



- ST-01 Speed gate p. 55



- TTR-10A Motorized tripod turnstile with automatic anti-panic barrier arms for outdoor application p. 65



- TTR-08A Tripod turnstile with automatic anti-panic barrier arms for outdoor application p. 71



- TTR-07.1 Tripod turnstile with automatic anti-panic barrier arms p. 78



- TTR-04.1 Tripod Turnstile for indoor application p. 85



- TTR-04CW Tripod Turnstile for outdoor application p. 92



- T-5 Tripod turnstile p. 100



- TTD-10A Box tripod turnstile p. 104



- TTD-08A Box tripod turnstile p. 113



- TB01.1A Box tripod turnstile p. 120
- TBC01.1A Box tripod turnstile p. 127



- TTD-03 Box tripod turnstile p. 134



- WMD-06 Motorized gate p. 142



- WMD-05S Motorized gate. p. 148



- WHD-05 Electromechanical gate p. 155



Contents

Waist-high railings..... p. 162



- BH02 Waist-high railing systems p. 162



- BH06 Waist-high railing systems p. 171

Full height rotor turnstiles, security gates and railings p. 173



- RTD-15 Full height rotor turnstile p. 173
- WHD-15 Full height security gate p. 184
- MB-15 Full height railings p. 187



- RTD-16 Full height rotor turnstile p. 193
- WHD-16 Full height security gate p. 214
- MB-16 Full height railings p. 217



- RTD-20 Full height rotor turnstile p. 204

Turnstiles, gates and railings

ST-11 Speed gate



+50
+1
temperature range

24V
operating voltage

160W
power consumption

2
passage directions

M
motor drive

60
persons/min

Application

ST-11 Speed gate with swing panels is designed for indoor operation. It is a perfect solution for sites with high aesthetic and comfort requirements.

Speed gate top covers can be made of artificial quartz stone or stainless steel. The swing panels of ST-11 can be of different width: 650 mm, 900 mm, and 1000 mm. The increased passageway width allows organizing an additional emergency exit and a convenient passage for people with reduced mobility. When passing through, the turnstile swing panels open.

If necessary, the number of passage zones can be increased by installing STD-11 double-sided sections. Each double-sided section allows arranging one extra passage zone. The tracking system is equipped with two levels of infrared sensors with 24 pairs located on the upper level and the other 24 on the lower level of the turnstile, which guarantees safety and high throughput and prevents tailgating.

The delivery set includes an RC-panel; the orientation of the RC-panel buttons relative to the passage directions is set when connecting to the turnstile.



RC-panel

Operating modes

The powered speed gate operates in a normally closed mode. It is possible to switch the turnstile to the additional "Automatic opening in the selected direction" mode, as well as to adjust initial position of the swing panels in the "training" mode.

The product provides independent control of the passage in two directions.

Control commands:

- passage denial
- authorized single passage in the set direction
- authorized free passage in the set direction
- authorized free passages in both directions

When the power is off, the turnstile panels are unlocked and can be moved manually in any direction.

Main features

- operation of the speed gate from RC-panel, WRC, ACS
- built-in electronic boards



ST-11 Speed gate

- safe voltage – 24 V
- power consumption – max. 160 W per passage
- two levels of infrared sensors control the passage zone; 24 pairs are located on the upper level and 24 – on the lower one
- possibility for several users to perform authorized single passages in a row in the same direction without the panels being closed
- 4 types of panels, both for different passageway widths (600, 900, and 1000 mm) and increased height (1300 mm for a passageway width of 600 mm)
- the number of passage zones can be increased with STD-11 double-sided section installation
- proximity card readers can be installed inside sections under the top covers (overall reader dimensions – max. 155x68x28 mm, reading range – min. 40 mm)
- central sections feature indication blocks of passage grant / denial
- indication of passage permission on the top covers of sections made of artificial stone (not provided on top covers made of stainless steel)
- reader interrogation zones are indicated with pictograms on stainless steel top covers
- possibility to adjust the panels position when in the closed position (training mode)
- Fire Alarm input for connecting the emergency passage opening device; when the command is sent from it, the panels automatically opened in one direction and it is possible to pass through the turnstile in both directions
- outputs for connecting remote indication blocks of passage grant / denial, as well as a sounder (sirens)
- two control modes: pulse and potential; it can operate both as a standalone unit controlled by the operator using an RC-panel and as a part of ACS

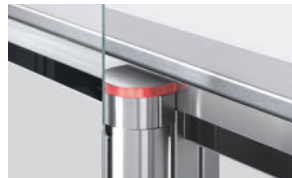

Turnstile mode indication



Turnstile mode indication (artificial stone top cover)

Design

Housing – stainless steel; filler panels – 8 mm tempered glass; top cover – glass and / or stainless steel; panels – 10 mm tempered glass.

The speed gate can be equipped with 4 types of swing panels.

Swing panels type	Passageway width	Barrier height
ATG-300	650 mm	915 mm
ATG-300H	650 mm	1300 mm
ATG-425	900 mm	915 mm
ATG-475	1000 mm	915 mm

Size 1 and Size 2 switches positioning on the ST-01.771 control board, depending on the type of swing panels:

Swing panels type	Switch position	
	Size 1	SIZE2
ATG-300	ON	OFF
ATG-300H	ON	ON
ATG-425, ATG-475	OFF	OFF

Operating conditions

The turnstile, with regard to resistance to environmental exposure, complies with GOST15150-69 category NF4 (operation in rooms with climate control).

The operation of the turnstile is allowed at ambient temperature from +1°C to +50°C and relative air humidity up to 80% at + 25°C.

It is a serially produced product certified for compliance with applicable Russian and European CE standards.

Delivery set

ST-11	
ST-11/M (Master) section	1
ST-11/S (Slave) section	1
Section top cover	2
Glass panel	2
RC-panel with cable	1
Documentation set: Certificate and Operation manual	1
STD-11	
STD-11 section	1
Section top cover	1
Glass panel	2
RC-panel with cable	1
Certificate	1

Technical specifications

Operating voltage	24 V	
Current consumption	6,5 A	
Power consumption	160 W	
Throughput in single passage mode	up to 60 persons / min	
Passageway width	ATG-300, ATG-300H	650 mm
	ATG-425	900 mm
	ATG-475	1000 mm
Mean time to failure	5,000,000 passages	
Mean lifetime	8 years	
ST-11 weight with swing panels	148 kg	
STD-11 weight with swing panels max.	98 kg	
Overall ST-11 dimensions *	with ATG-300 swing panels	1236×944×1022 mm
	with ATG-300H swing panels	1236×944×1300 mm
	with ATG-425 swing panels	1236×1194×1022 mm
	with ATG-475 swing panels	1236×1294×1022 mm

* Calculation of overall dimensions when organizing several passage zones:

$L_{total} = 864n + 1114m + 1214k + 84$ (mm), being:

n – the number of installed pairs of ATG-300 and ATG-300H swing panels;

m – the number of installed pairs of ATG-425 swing panels;

k – the number of installed pairs of ATG-475 swing panels.

Connection

The sections are equipped with integrated electronic boards. The Slave section (side of the bidirectional section) is connected by its standard cables to the Master section (side of the bidirectional section) of one passage zone. The Master section (side of the bidirectional section) is equipped with the ST-01.771 control board (located at the bottom of the central section post behind the cover plate). All external connections are made to this board contacts. Microcontrollers, installed on the boards, control the drives of the swing panels, process signals from IR sensors, process external commands, and generate signals about passages through the turnstile.



ST-11 Speed gate

ST-01.770 control board contacts description by connectors			
Connector	Contact	Electrical circuit	Designation
X1 (Power)	1	+24V	External power supply connection
	2	GND	
X2 (RC)	1	GND	Common
	2	Unlock A	Direction A control input
	3	Stop	Control input – passage denial
	4	Unlock B	Direction B control input
	5	Led A	Indication output of direction A on the RC-panel
	6	Led Stop	Indication output of passage denial on the RC-panel
	7	Led B	Indication output of direction B on the RC-panel
	8	Sound	RC-panel sound signal output
	9	Fire Alarm	Emergency passage opening control input
	10	GND	
X3 (ACS)	1	+12V	+12V output for powering additional devices
	2	GND	Common
	3	Alarm1	Siren connection output
	4	Alarm2	
	5	Common	Common for PASS A, PASS B outputs
	6	PASS A	PASS A relay contact (passage in the direction A)
	7	PASS B	PASS B relay contact (passage in the direction B)
X4	1	NO1	Normally open Light A output contact
	2	C1	Common Light A output contact
	3	NC	Common Light A output contact
	4	NO2	Normally open Light B output contact
	5	C2	Common Light B output contact
	6	NC2	Normally closed Light B output contact

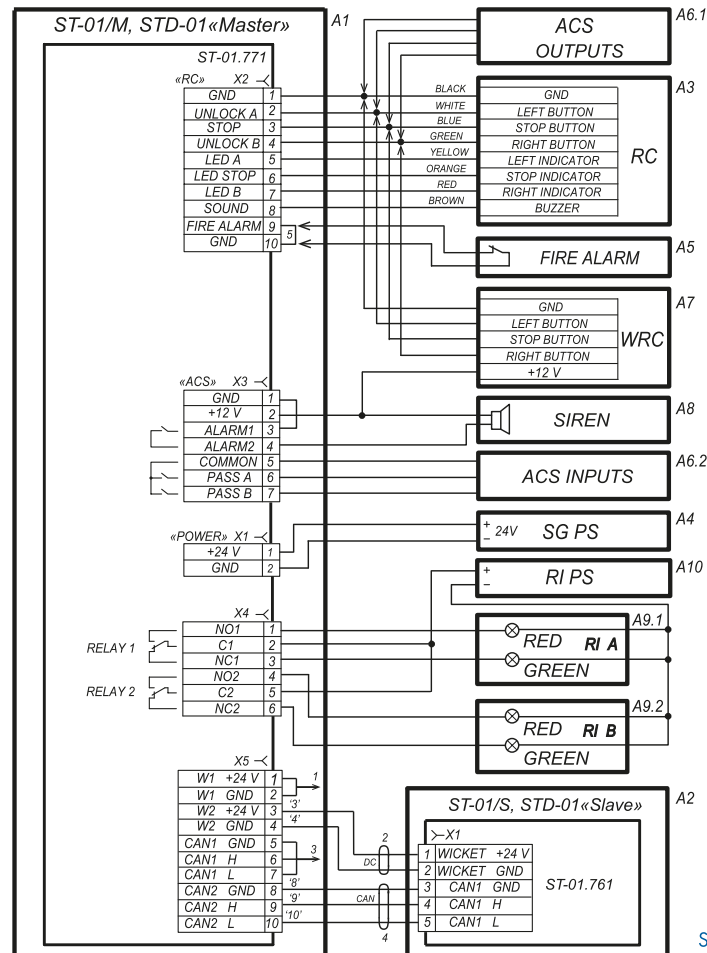

ST-11 connection layout



Layout description		
Item	Description	
A1	Master section (section side)	1
A1.1	Control board	1
A1.2	Drive control board, Master section (section side)	1
A2	Slave section (section side)	1
A2.1	Drive control board, Slave section (section side)	1
A3	RC-panel	1
A4*	Speed gate power supply	1
A5*	Fire Alarm signal sending device	1
A6.1*, A6.2*	ACS controller	1
A7*	WRC	1
A8*	12V DC siren	1
A9.1*, A9.2*	Remote indication block	2
A10*	Remote indicators power supply	1
1, 2	DC connection cable	2
3, 4	CAN connection cable	2
5	Jumper wire in case there is no Fire Alarm device (A5). Installed by default.	1

*The equipment is not included in the standard delivery set

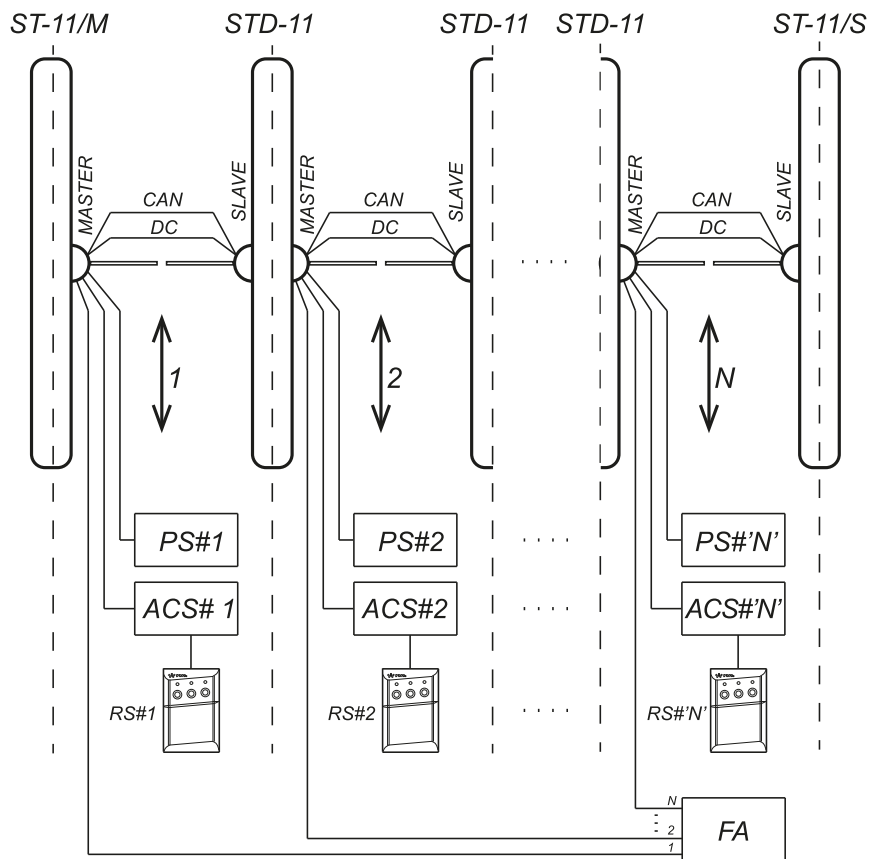

The connection layout of the ST-11 turnstiles and the two-sided sections STD-11 to organize the checkpoint with several passage zones



ST-11 Speed gate

The speed gate can operate from the RC-panel (included in the delivery set), WRC, and ACS controller.

The operation is performed by applying a low-level signal to Unlock A, Stop, and Unlock B contacts relative to the GND contact. The response to these signals depends on the control mode selected by the Pulse switch.

Pulse control mode (Pulse switch in the ON position) is when a pulse is applied to the Unlock A (B) input, the speed gate panels will automatically open for a single passage in the A (B) direction. The waiting time for the passage being completed does not depend on the duration of the control pulse and lasts 8 seconds. Sending a pulse to the Stop input closes the panels from any position, thus, blocking the passage. Simultaneous sending of pulses to the Unlock A (B) and Stop inputs switches the turnstile in the "Free passage" mode in the selected direction.

It is recommended to use the pulse mode when operating from an RC-panel or WRC. The orientation of the RC-panel buttons can be changed by swapping the wires from the RC-panel that are connected to the unlock A and Unlock B contacts, as well as Led A and Led B, respectively.

Potential control mode (Pulse switch in the OFF position) is when the control signal is applied to the Unlock A (B) input, the glass panels open in the selected direction during the entire holding signal time. Sending the control signal to the Stop input closes the sliding panels, thus, blocking the passage, regardless of the signals at the Unlock A (B) inputs.

Potential mode is recommended when operating from the ACS controller.

Regardless of the selected control mode, the PASS A or PASS B signals are generated when passing in one direction or the other. These signals can inform the ACS controller of the fact of passage.

Emergency opening of the passage zone is performed by removing a low-level signal from the Fire Alarm contact relative to the GND contact.

The product also features the additional "Automatic opening in the selected direction" mode (R1 switch in the ON position). This is a mode of free passage through the turnstile in one preselected direction (selected by the R2 switch) with automatic opening and closing of the panels during passage.

The training mode (R1 switch in the OFF position, and R2 switch on the ST-01.771 control board in the ON position) allows manually adjusting the home (closed) position of the turnstile swing panels.

Note

When operating the speed gate from the ACS controller, it is recommended to connect the RC-panel to the ACS controller.

The maximum allowed cable length from the RC-panel (ACS controller) is 40 meters.

The maximum allowed cable length from the power supply depends on its cross section and must be:

- for 1.5 mm² cable – 10 meters
- for 2.5 mm² cable – 20 meters



Example of connection to the ACS

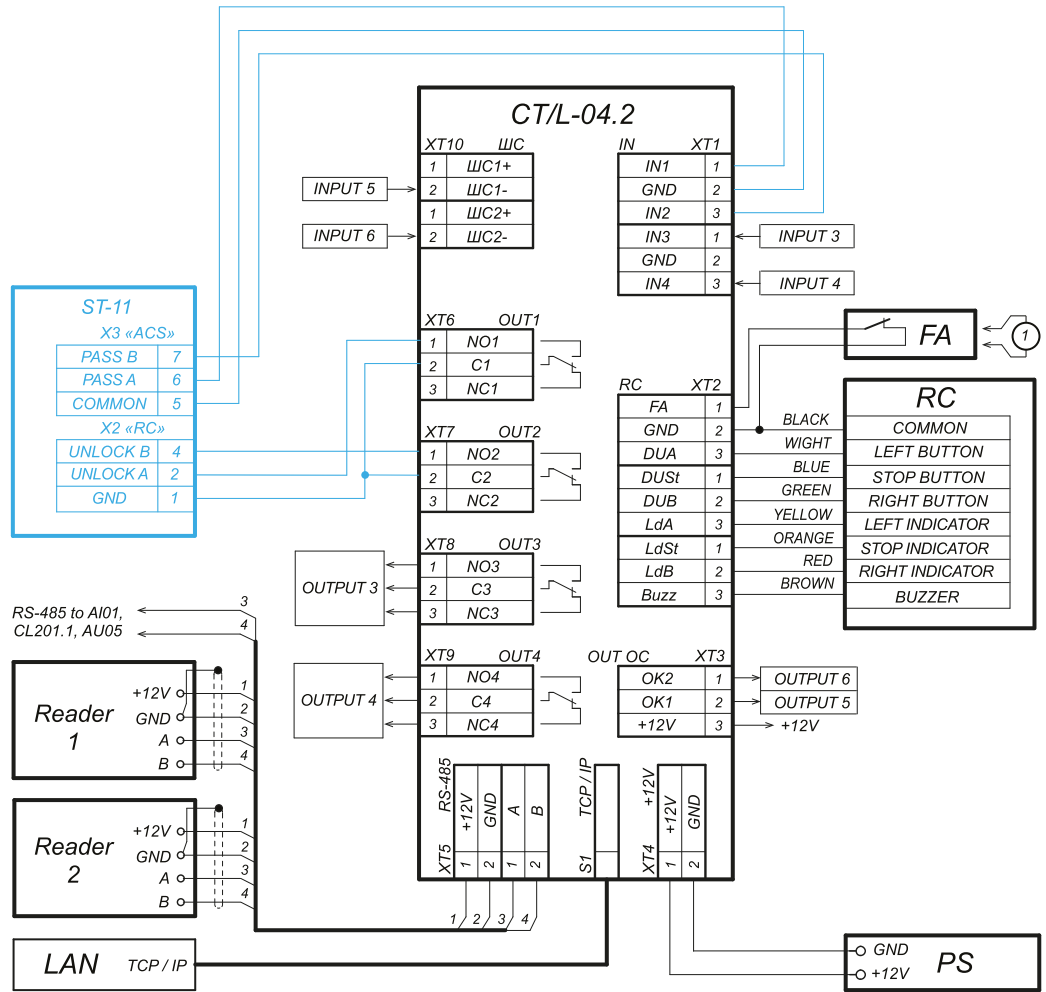

1 - jumper wire, installed when there is no FA device

Overall dimensions

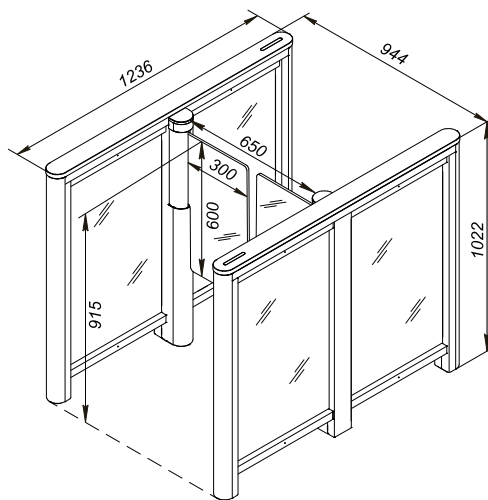

ATG-300 swing panels

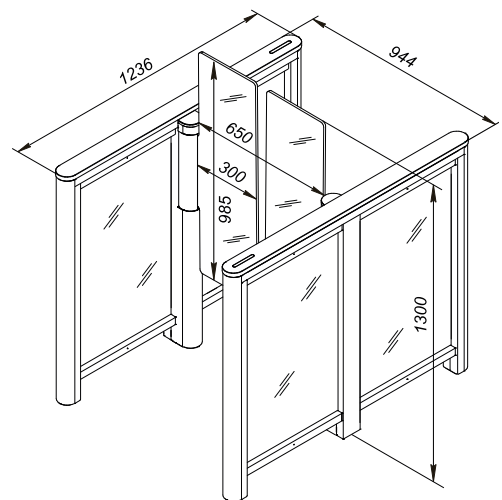

ATG-300H swing panels



ST-11 Speed gate

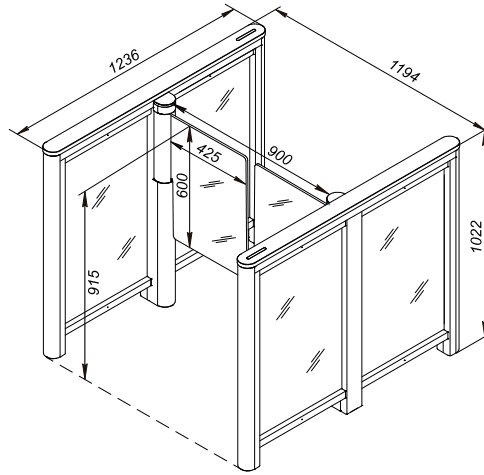

ATG-425 swing panels

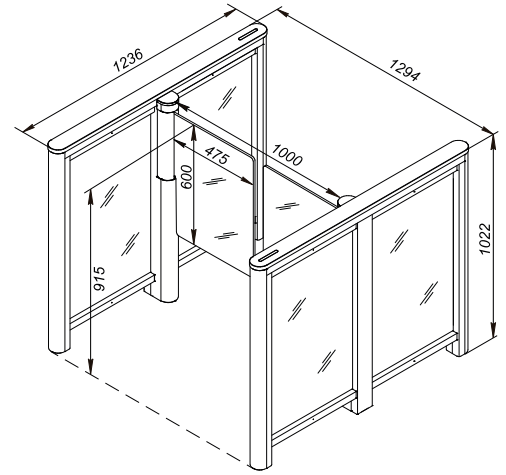

ATG-475 swing panels

Mounting

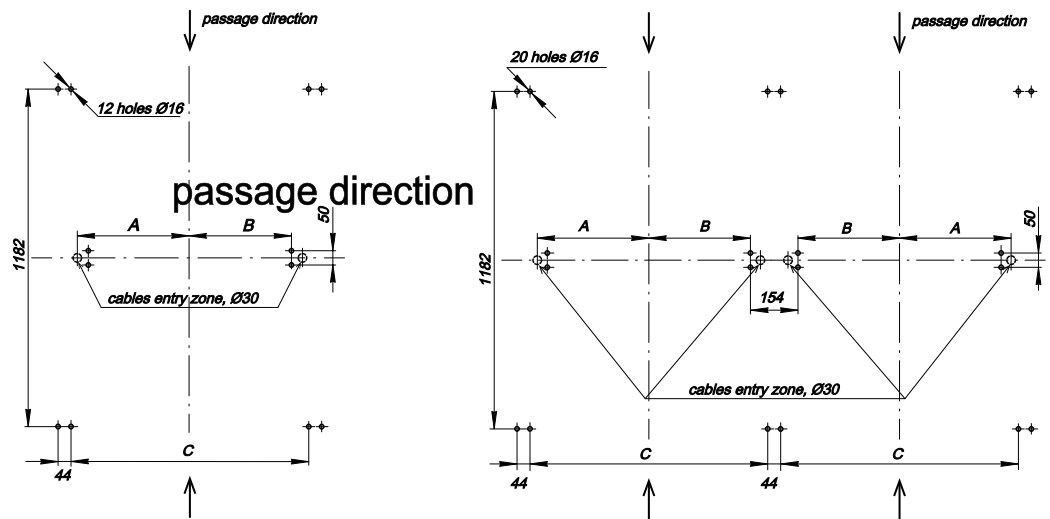

for ATG-300, ATG-300H: A = 388, B = 354, C = 818
for ATG-425: A = 513, B = 479, C = 1068
for ATG-475: A = 563, B = 529, C = 1168

Hole marking for sections mounting and cable entry zone

Foundation requirements: concrete (grade 400 or higher), stone, etc. foundation of at least 150 mm thick, use reinforcing elements (450x450x200 mm) when installing sections on a less steady foundation.

Warranty

The warranty period is 5 (five) years commencing from the date of sale, unless otherwise determined in the delivery contract of the Product. In case of sale and installation of the equipment by authorized PERCo dealers and service centers, the warranty starts from the date of commissioning.

Should there be no date of sale on the warranty card, the warranty period shall commence from the date of manufacture specified in the Certificate and on the Product label.



+50
+1
temperature range

24V
operating voltage

204 W
power consumption

2
passage direction

M
motor drive

60
persons/min

Application

ST-02 Speed gate with sliding panels is designed for indoor operation. It is an ideal solution for sites with high aesthetic and comfort requirements.

ST-02 is available in two versions: a standard passageway width of 600 mm (ST-02.600 version) or an extended one of 900 mm (ST-02.900). The extended version provides convenient access for people in wheelchairs and ensures free passage in case of an emergency. The panels are sliding away when a passage takes place.

If an increased number of passage lanes is needed, STD-02 double-sided sections can be installed. Each double-sided section allows arranging one extra passage lane. STD-02 is available in two main versions: STD-02.600 and STD-02.900 for organizing passage lanes with a width of 600 mm and 900 mm, respectively.

ST-02.600/900 is available on a separate order to arrange passage lanes of different widths (600 and 900 mm). For the same purpose, the STD-02.900 double-sided section has the possibility of reducing one panel to 600 mm.

The tracking system is equipped with two levels of infrared sensors, which guarantees the safety of passage at high throughput and provides avoiding the simultaneous passage of two or more people.



RC-panel

Operating modes

The speed gate supports two main operating modes: normally closed and normally open, as well as an additional "Automatic opening in the selected direction" mode (only in normally closed mode).

Control commands:

- passage denial,
- authorized single passage in the set direction
- authorized free passage in the set direction
- authorized free passage in both directions

When the power is off, the sliding panels are unlocked and can be moved away manually.

Main features

- operation of the speed gate from RC-panel, WRC, ACS
- built into the housing electronic boards
- safe voltage – 24 V



ST-02 Speed gate

- power consumption – max. 204 W per passage
- upper and lower levels of infrared sensors of the passageway, 30 sensors on each level
- possibility to perform authorized single passage of several users one after the other in a row in the same direction without closing the panels increases the throughput capacity
- closing the passage zone with panels; space above the sections can be overlapped with additional glass panels of up to a height of 148 cm
- if necessary, the number of passage lanes through the turnstile can be increased by installing STD-02 double-sided sections
- possibility to install proximity card readers inside sections under the glass top cover (overall reader dimensions – max. 230x72x32 mm, reading range – min. 40 mm)
- there is a place for installing the ACS controller inside the section (overall dimensions – max. 160x140x40 mm)
- section glass top covers feature grant/denial passage indication
- reader interrogation zones are indicated with backlit pictograms
- backlit lateral indication of passage direction
- Fire Alarm input for connecting the emergency passage opening device; when the command is sent from it, the panels are automatically opened and it is possible to walk through in both directions
- outputs for connecting remote indication blocks of passage grant / denial, as well as a sounder (sirens)
- two control modes: pulse and potential; it can operate both as a standalone unit controlled by the operator using RC-panel and as a part of ACS



Turnstile mode indication



Passage direction indication

Design

Housing – stainless steel; panels and filling glass – 8 mm tempered glass; section top cover – 10 mm tempered glass.

Operating conditions

The product with regard to resistance to environmental exposure complies with GOST15150-69 category NF4 (operation in premises with climate control).

The operation of the turnstile is allowed at ambient temperature from +1 °C to +50 °C and relative air humidity up to 80% at + 25 °C.

It is a serially produced product certified for compliance with applicable Russian and European CE standards.

Delivery set

ST-02	
Master section with mounting kit	1
Slave section with mounting kit	1
Glass top cover	4
Filling glass	2
Glass sliding panel	2
Side panel	4



Technical specifications

Central insert		2
RC-panel with cable		1
Documentation set: Certificate and Operation manual		1
STD-02		
Section with top cover and mounting kit		1
Glass top cover		2
Filling glass		1
Glass sliding panel		2
Side panel		2
Central insert		1
RC-panel with cable		1
Certificate		1
Operating voltage		24 V
Consumption current		8.5 A
Power consumption		204 W
Throughput in single passage mode		up to 60 persons / min
Passageway width	ST-02.600	600 mm
	ST-02.900	900 mm
Mean time to failure		2,000,000 passages
Mean lifetime		8 years
ST-02.600 weight (two sections with sliding panels and inserts)		424 kg
ST-02.900 weight (two sections with sliding panels and inserts)		488 kg
ST-02.600 weight (one section with sliding panels and inserts)		251 kg
ST-02.900 weight (one section with sliding panels and inserts)		263 kg
Overall turnstile dimensions*	ST-02.600	1923x1364x1482 mm
	ST-02.900	1923x1964x1482 mm

* The total width of a turnstile with double-sided sections when organizing multiple passage lanes is calculated using the formula

Ltotal = 600N + 382n + 900M + 532m (mm), being:

N – number of 600 mm-wide passage lanes, **n** – number of ST-02.600/M (S) and STD-02.600 sections, **M** – number of 900 mm-wide passage lanes, **m** – number of ST-02.900/M (S) and STD-02.900 sections.

Connection

Sections are equipped with integrated electronic boards. Master and Slave sections (sides of the bidirectional section) of the same passage lane are connected by standard CAN and DC cables. For external connections and connections between sections, each section (side of the bidirectional section) features a remote terminal block (DIN rail) at the bottom of the inner side panel. The master section (side of the bidirectional section) is equipped with a ST-02.-30.771 control board (located inside the section under one of the glass top covers). Microcontrollers installed on the boards, control the sliding panels drives, process signals from IR sensors, process external commands, and generate signals about passages through the turnstile.

Designation of the external terminal block contacts on the DIN rail			
No.	Contact	Master section	Slave section
1	+24V	Connecting an external power supply	Not used
2	GND		
3	+24V	Power supply to the Slave section (DC cable connection)	Power supply from the Master section (DC cable connection)
4	GND		
5	GND	CAN cable connection	CAN cable connection
6	H		
7	L		



ST-02 Speed gate

8	GND	Common (RC-panel connection)	
9	Unlock A	Direction A control input	
10	Stop	Control input – passage denial	
11	Unlock B	Direction B control input	Not installed
12	Led A	Indication output of direction A on the RC-panel	
13	Led Stop	Indication output of passage denial on the RC-panel	
14	Led B	Indication output of direction A on the RC-panel	
15	Sound	RC-panel sound signal output	
16	Fire Alarm	Emergency passage opening control input	
17	GND		
18	+12V	GND	Not installed
19	GND	+12 V	
20	Alarm1		
21	Alarm2	Siren connection output	
22	Common	Common for PASS A, PASS B outputs	
23	PASS A	PASS A output (passage in the direction A)	
24	PASS B	PASS B output (passage in the direction B)	
25			
26			
27	RF	Spare contact for a built-in reader connection	Spare contact for a built-in reader connection
28			

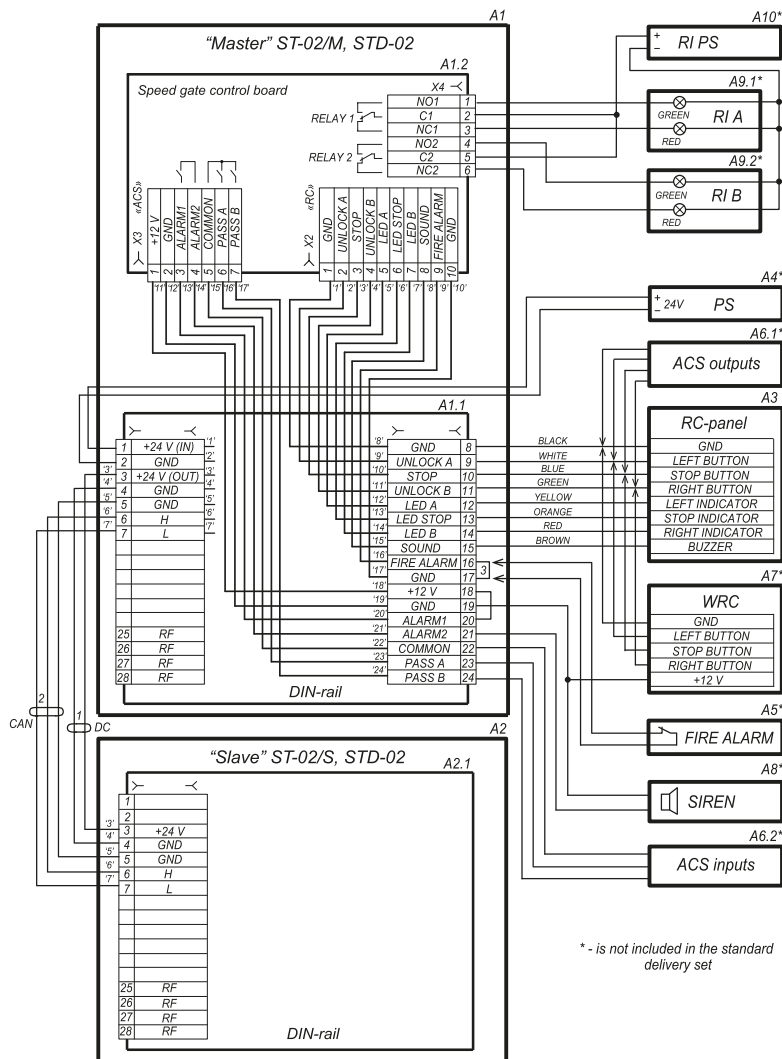

ST-02 speed gate wiring diagram



Diagram description		
Item	Description	Q-ty, pcs.
A1	Master section (side of the section)	1
A1.1	Remote terminal block (DIN rail) of the Master section	1
A1.2	Control board	1
A2	Slave section (side of the section)	1
A2.1	Remote terminal block (DIN rail) of the Slave section	1
A3	RC-panel	1
A4	Turnstile power supply	1
A5	Device for sending the FireAlarm command	1
A6 (A6.1, A6.2)	ACS controller	1
A7	WRC	1
A8	12V DC siren	1
A9.1 A9.2	Remote indication block	2
A10	Power supply for remote indicators	1
A11	RF1 and RF2 access card readers	2
1	DC connection cable	1
2	CAN connection cable	1
3	Jumper wire in case there is no Fire Alarm device (A5). Installed by default	1

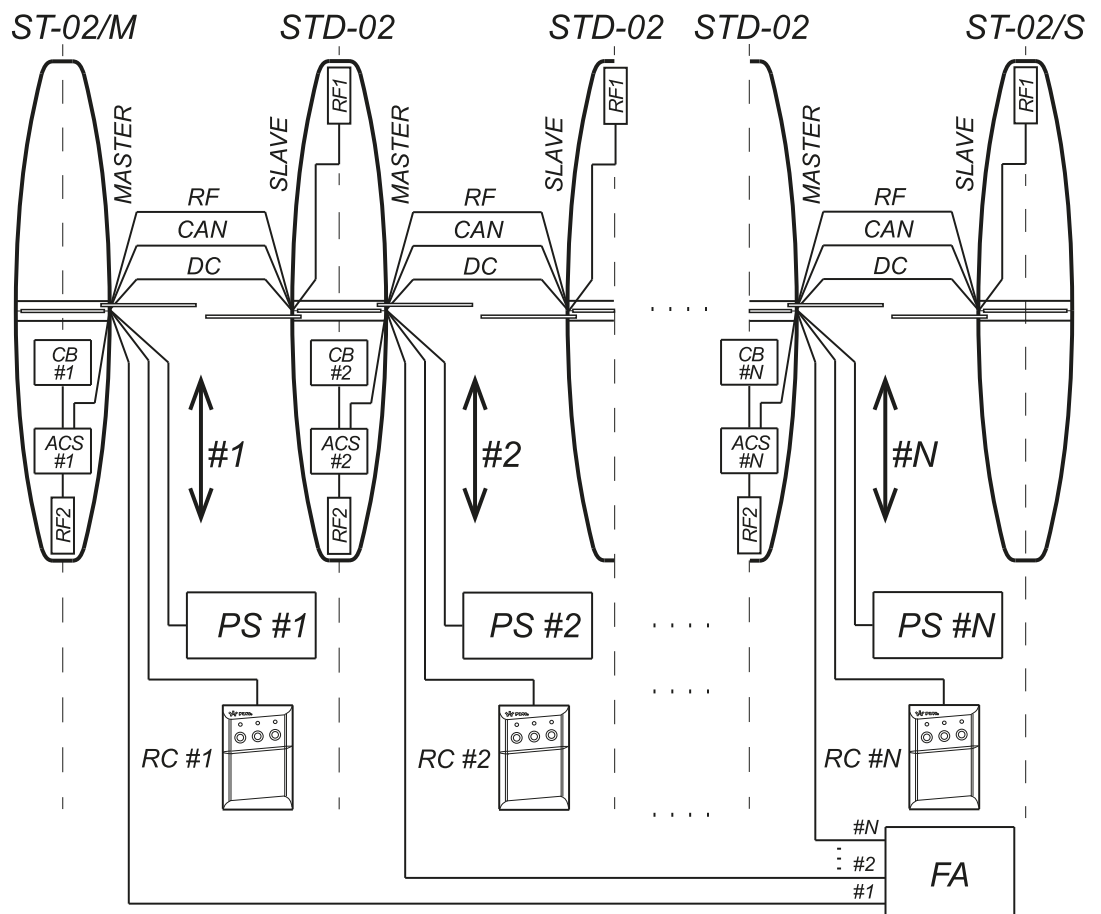

Connection layout of the ST-02 turnstile and STD-02 bidirectional sections to arrange a passage zone with several passage lanes



ST-02 Speed gate

Operation algorithm

The speed gate can operate from the RC-panel (included in the delivery set), from the WRC and from the ACS controller.

Operation is performed by applying a low-level signal to unlock A, Stop and Unlock B contacts relative to the GND contact. The response to these signals depends on the control mode selected by the Pulse switch.

Pulse control mode (Pulse switch in the ON position) is when a pulse is applied to the Unlock A (B) input, the speed gate panels will automatically open for a single passage in the A (B) direction. The waiting time for the passage being completed does not depend on the duration of the control pulse and lasts 8 seconds. Sending impulse to the Stop input closes the panels from any position, thus blocking the passage. Simultaneous sending of pulses to Unlock A (B) and Stop inputs places the turnstile in the "Free passage" mode in the selected direction.

It is recommended to use pulse mode when operating from RC-panel or WRC. The orientation of RC-panel buttons can be changed by swapping the wires from the RC-panel that are connected to unlock A and Unlock B contacts, as well as Led A and Led B contacts, respectively.

Potential control mode (Pulse switch in the OFF position) is when the control signal is applied to Unlock A (B) input, the glass panels slide away for passage in the selected direction during the entire holding signal time. Sending the control signal to the Stop input closes the sliding panels, thereby blocking the passage, regardless of the signals at the Unlock A (B) inputs.

Potential mode recommended when operating from the ACS controller.

Regardless of the selected control mode, PASS A or PASS B signals are generated when walking through the turnstile in one direction or the other. These signals can inform the ACS controller of the fact of passage.

The emergency opening of the passage is performed by removing a low-level signal from the Fire Alarm contact relative to the GND contact.

Turnstile also features:

1. Normally closed and normally open operating mode (selected by the "XP2 Mode 1" jumper)
2. Additional "Automatic opening in the selected direction" mode (R1 switch in the ON position), this mode is only relevant in normally closed operating mode. This is a mode of free passage through the turnstile in one pre-selected direction (selected by the R2 switch) with automatic opening and closing of the panels during the passage.

Note:

When operating the speed gate from the ACS controller, it is recommended to connect the RC-panel to the ACS controller.

The maximum allowed cable length of the RC-panel (ACS controller) is 40 meters.

The maximum allowed cable length of the power supply depends on its cross section and must be:

- for 1.5 mm² cable – 10 meters
- for 2.5 mm² cable – 20 meters



Example of connection to the ACS

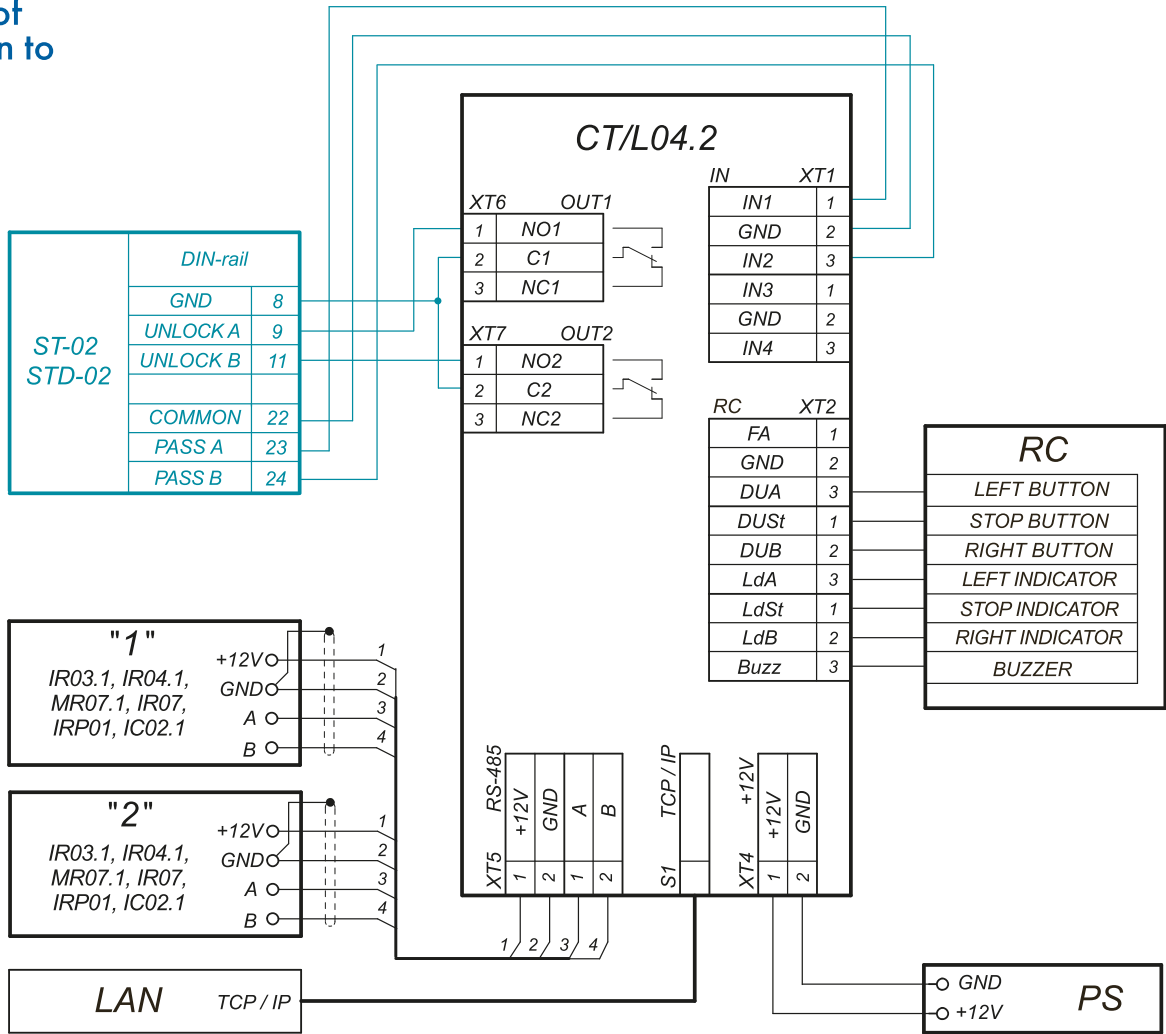

Example of the speed gate connection to ACS controller

Overall dimensions

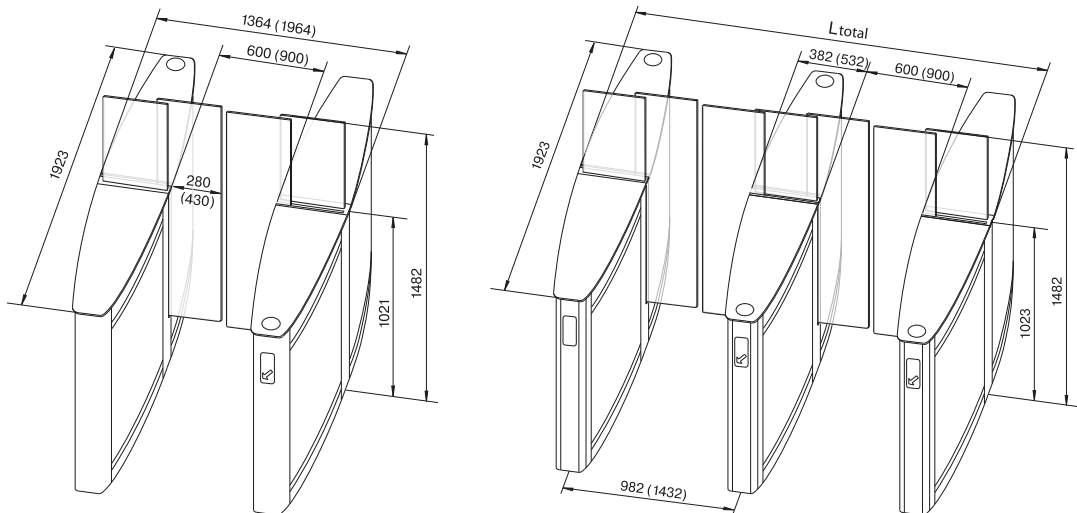

Overall dimensions



ST-02 Speed gate

Mounting

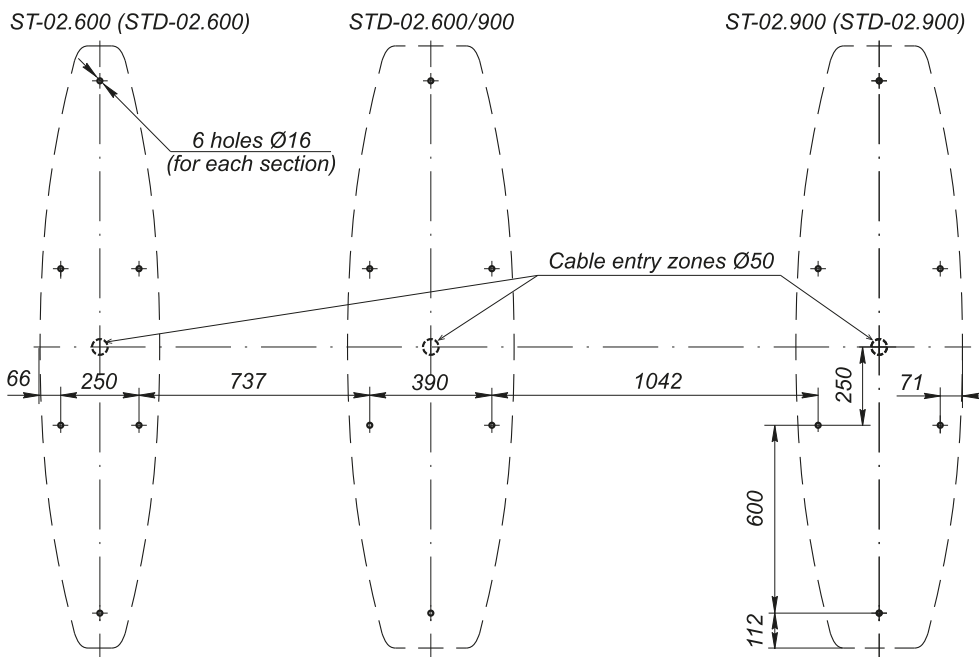
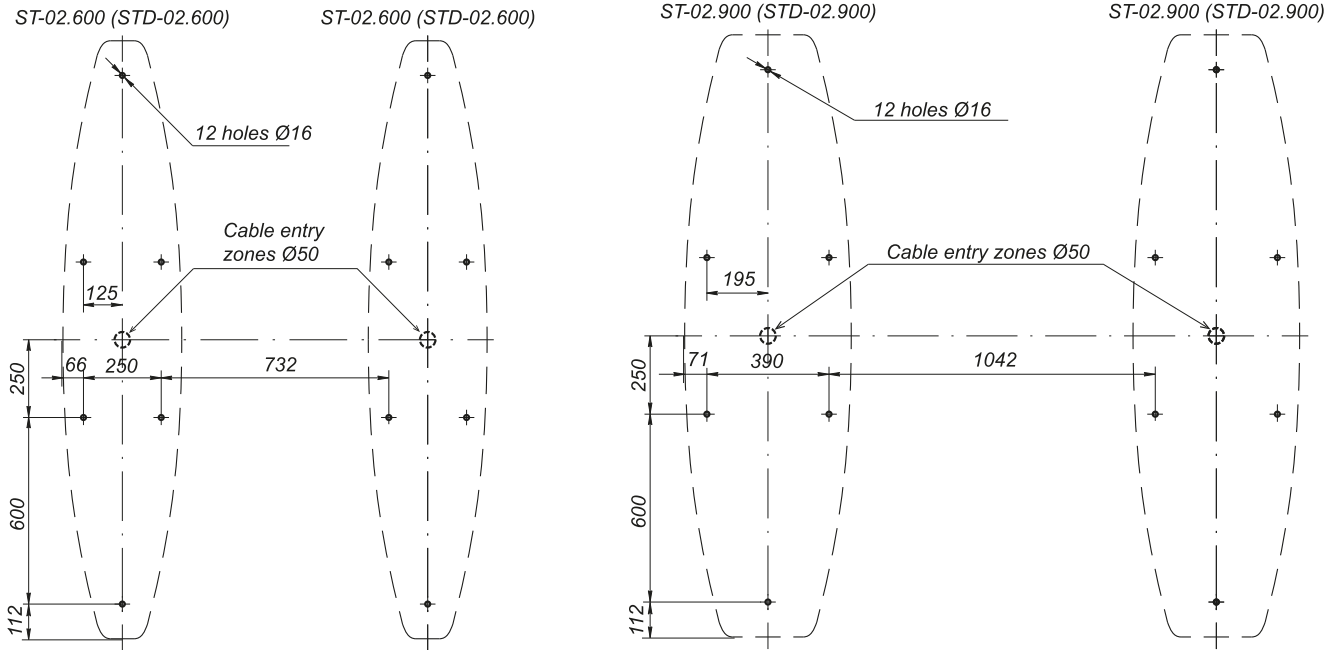

Hole marking for speed gate sections installation and cable entry zone

Foundation requirements: concrete (not lower than 400 grade), stone, etc. foundation of at least 150 mm thick, use reinforcing elements (450x450x200 mm) when installing sections on a less steady foundation.

Warranty

The warranty period is 5 (five) years commencing from the date of sale, unless otherwise determined in the delivery contract of the Product. In case of sale and installation of the equipment by authorized PERCo dealers and service centers, the warranty starts from the date of commissioning. Should there be no date of sale on the warranty card, the warranty period shall commence from the date of manufacture specified in the Certificate and on the Product label.

ST-01 Speed gate



+50
+1
temperature range

24V
operating voltage

160W
power consumption

2
passage direction

M
motor drive

60
persons/min

Application

ST-01 Speed gate with swing panels is designed for indoor operation. It is an ideal solution for sites with high aesthetic and comfort requirements.

Speed gate top covers can be made of tempered glass or stainless steel. The swing panels of ST-01 can be of different width: 650 mm, 900 mm, and 1000 mm. 900 mm and 1000 mm swing panels are designed for people in wheelchairs, and can be used as an additional emergency exit. The swing panels are moving away when a passage takes place.

Turnstiles, gates and railings



ST-01 Speed gate with stainless steel top covers

If an increased number of passage lanes is needed, STD-01 double-sided sections can be installed. Each double-sided section allows arranging one extra passage lane. Various versions of ST-01 are available to install optional equipment: a built-in card reader (the turnstile includes the FP-01C front panel), a built-in barcode scanner (with the FP-01Q front panel), as well as a bracket for installing other optional equipment (with the FP-01A front panel).



Bracket for mounting optional equipment



ST-01 Speed gate



ST-01 Speed gate with a post for embedding a barcode scanner



ST-01 Speed gate with a built-in card capture reader

Operating modes

The tracking system is equipped with two levels of infrared sensors: 14 pairs are located on the upper level and 28 – on the lower one, which guarantees the safety of passage at high throughput and provides avoiding simultaneous passage of two or more people.

The delivery set includes an RC-panel; the orientation of the RC-panel buttons relative to the directions of passage is set when connecting to the turnstile.

The powered speed gate operates in normally closed mode. It is possible to switch the turnstile to the additional "Automatic opening in the selected direction" mode, as well as to adjust the home position of the swing panels in the "training" mode.

The product provides independent control of the passage in two directions. Control commands:

- passage denial
- authorized single passage in the set direction
- authorized free passage in the set direction
- authorized free passage in both directions

When the power is off, the turnstile panels are unlocked and can be moved manually in any direction.



Main features

- operation of the speed gate from RC-panel, WRC, ACS
- built-in electronic boards
- safe voltage – 24 V
- power consumption – max. 160 W per passage
- two levels of infrared sensors control the passage zone, 14 pairs are located on the upper level and 28 – on the lower one
- possibility for several users to perform authorized single passages in a row in the same direction without the panels being closed
- 4 versions of panels, both for different passageway widths (600, 900 and 1000 mm) and with increased height (1300 mm for a passageway width of 600 mm)
- several different versions of the turnstile front panels that allow integrating optional equipment: a card reader, a barcode scanner, a face recognition terminal, etc.
- if necessary, the number of passage lanes through the turnstile can be increased by installing STD-01 double-sided sections
- possibility to install proximity card readers inside sections under the glass top cover (overall reader dimensions – max. 155x68x28 mm, reading range – min. 40 mm)
- central sections feature indication blocks of passage grant / denial
- section top covers feature passage indication
- reader interrogation zones are indicated with backlit pictograms
- backlit lateral indication of passage direction
- possibility to adjust the panels position when in the closed position (training mode)
- Fire Alarm input for connecting the emergency passage opening device; when the command is sent from it, the panels are automatically opened in one direction and it is possible to walk through the turnstile in both directions
- outputs for connecting remote indication blocks of passage grant / denial, as well as a sounder (sirens)
- two control modes: pulse and potential; it can operate both as a standalone unit controlled by the operator using an RC-panel and as a part of ACS



Turnstile mode indication



Turnstile mode indication



Passage direction indication

Design

Housing – stainless steel; section filling – 8 mm tempered glass; top cover – glass and / or stainless steel; panels – 10 mm tempered glass.

The speed gate can be equipped with 5 types of swing panels.

Swing panels type	Passageway width	Passageway height
ATG-300	650 mm	915 mm
ATG-300H	650 mm	1300 mm
ATG-425	900 mm	915 mm
ATG-475	1000 mm	915 mm
ATG-575	1200 mm	915 mm



ST-01 Speed gate

Size1 and **Size2** switches positioning on the St-01.771 control board, depending on the type of swing panels:

Swing panels type	Switches position	
	Size 1	Size 2
ATG-300	ON	OFF
ATG-300H	ON	ON
ATG-425, ATG-475	OFF	OFF
ATG-575	OFF	ON

Operating conditions

The product with regard to resistance to environmental exposure complies with GOST15150-69 category NF4 (operation in premises with climate control).

The operation of the turnstile is allowed at ambient temperature from +1°C to +50°C and relative air humidity up to 80% at + 25°C.

It is a serially produced product certified for compliance with applicable Russian and European CE standards.



Delivery set

ST-01	
ST-01/M (Master) section	1
ST-01/S (Slave) section	1
Section top cover	2
Glass swing panel	2
RC-panel with cable	1
Documentation set: Certificate and Operation manual	1
STD-01	
Section with top cover and mounting kit	1
Glass swing panel	2
RC-panel with cable	1
Certificate	1

Technical specifications

Operating voltage	24 V	
Consumption current	6.5 A	
Power consumption	160 W	
Throughput in single passage mode	up to 60 persons / min	
Passageway width	with ATG-300, ATG-300H swing panels	650 mm
	with ATG-475 swing panels	1000 mm
Mean time to failure	5,000,000 passages	
Mean lifetime	8 years	
ST-01 weight with swing panels	188 kg	
STD-01 weight with swing panels	max. 118 kg	
Overall ST-01 dimensions (without including FP-01C, FP-01Q, FP-01A front panels):*	with ATG-300 swing panels	1820x1050x1010 mm
	with ATG-300H swing panels	1820x1050x1300 mm
	with ATG-425 swing panels	1820x1300x1010 mm
	with ATG-475 swing panels	1820x1400x1010 mm
	with ATG-575 swing panels	1820x1600x1010 mm

* Overall dimensions when organizing multiple passage lanes using several STD-01

Ltotal = 920**n** + 1170**m** + 1270**k** + 130 (mm), being:

n – the number of installed pairs of ATG-300 and ATG-300H swing panels;

m – the number of installed pairs of ATG-425 swing panels;

k – the number of installed pairs of ATG-475 swing panels.

Connection

The slave section (side of the bidirectional section) is connected by its standard cables to the Master section (side of the bidirectional section) of one passage lane. The master section (side of the bidirectional section) is equipped with the ST-01.771 control board (located at the bottom of the central section post behind the cover plate). All external connections are made to the board contacts. Microcontrollers installed on the boards control the drives of the swing panels, process signals from IR sensors, process external commands, and generate signals about passages through the turnstile.

ST-01.770 control board contacts description by connectors			
Connector	Contact	Electrical circuit	Designation
X1 (POWER)	1	24V	External power supply connection
	2	GND	
X2 (RC)	1	GND	Common
	2	Unlock A	Direction A control input
	3	Stop	Control input – passage denial
	4	Unlock B	Direction B control input
	5	Led A	Indication output of direction A on the RC-panel
	6	Led Stop	Indication output of passage denial on the RC-panel
	7	Led B	Indication output of direction B on the RC-panel
	8	Sound	RC-panel sound signal output
	9	Fire Alarm	Emergency passage opening control input
	10	GND	



ST-01 Speed gate

X3 (ACS)	1	+12 V, GND	+12V output for powering additional devices
	2	GND	Common
	3	Alarm1	Siren connection output
	4	Alarm2	
	5	Common	Common for PASS A, PASS B outputs
	6	PASS A	PASS A relay contact (passage in the direction A)
	7	PASS B	PASS B relay contact (passage in the direction B)
X4	1	NO1	Normally open Light A output contact
	2	C1	Common Light A output contact
	3	NC	Common Light A output contact
	4	NO2	Normally open Light B output contact
	5	C2	Common Light B output contact
	6	NC2	Normally closed Light B output contact

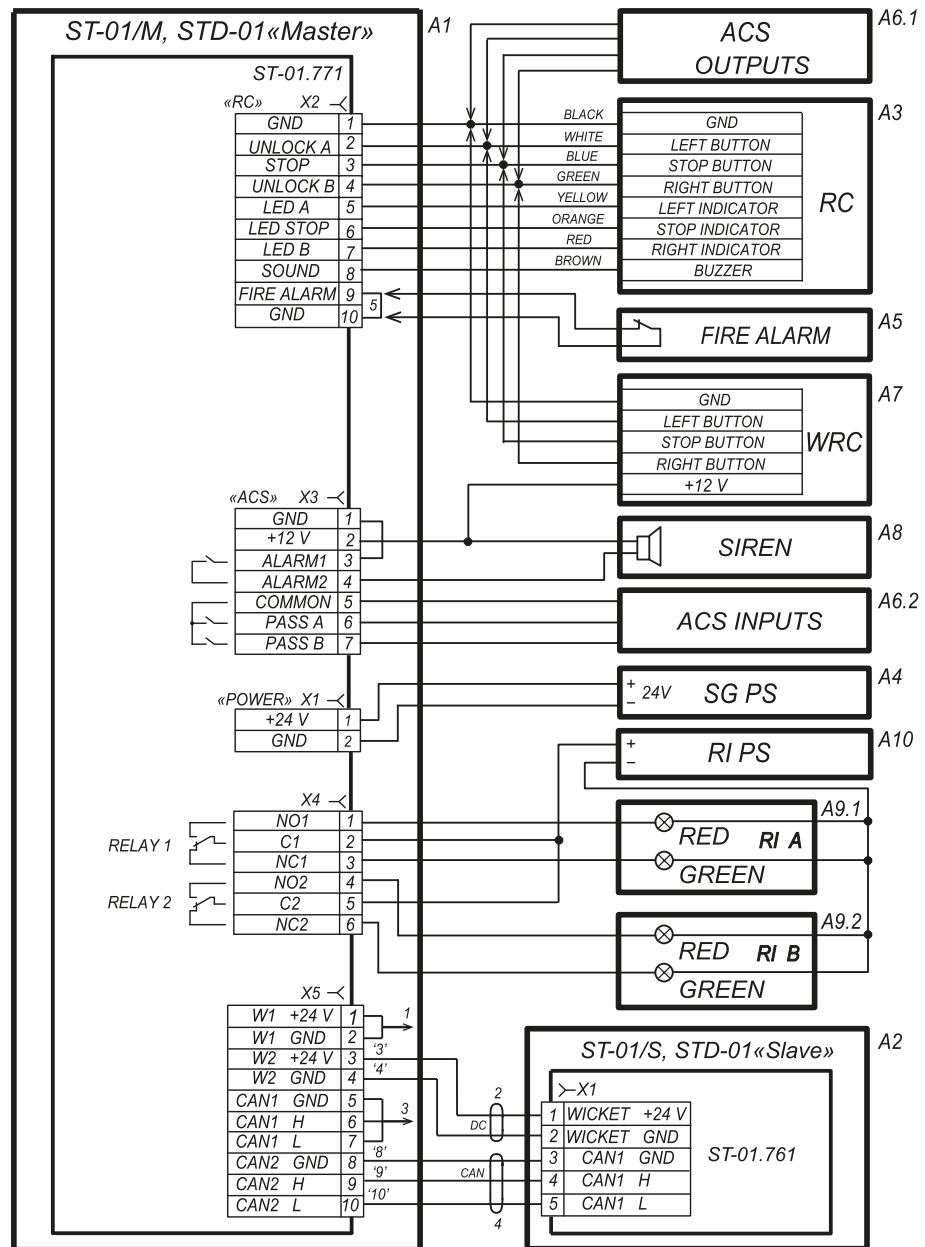

* ST-01 Speed gate wiring diagram



Layout description	
Item	Description
A1	Master section (side of the section)
A2	Slave section (side of the section)
A3	RC-panel
A4*	Turnstile power supply
A5*	Device for sending FireAlarm command
A6*, A6.2*	ACS controller
A7*	WRC
A8*	12V DC siren
A9.1*, A9.2*	Remote indication block
A10*	Remote indicators PS
1, 2	DC connection cable
3, 4	CAN connection cable
5	Jumper wire in case there is no Fire Alarm device (A5). Installed by default.

* The equipment is not included in the standard delivery set

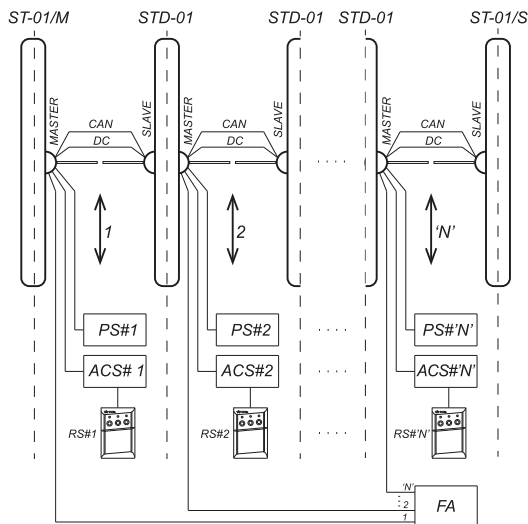

Connection of the ST-01 turnstile and STD-01 bidirectional sections to arrange a passage zone with several passage lanes

Operation algorithm

The speed gate can operate from an RC-panel (included in the delivery set), WRC and ACS controller.

Operation is performed by applying a low-level signal to Unlock A, Stop and Unlock B contacts relative to the GND contact. The response to these signals depends on the control mode selected by the Pulse switch.

Pulse control mode (Pulse switch in the ON position) is when a pulse is applied to the Unlock A (B) input, the speed gate panels will automatically open for a single passage in the A (B) direction. The waiting time for the passage being completed does not depend on the duration of the control pulse and lasts 8 seconds. Sending impulse to the Stop input closes the panels from any position, thus blocking the passage. Simultaneous sending of pulses to the Unlock A (B) and Stop inputs places the turnstile in the "Free passage" mode in the selected direction.

It is recommended to use pulse mode when operating from an RC-panel or WRC. The orientation of the RC-panel buttons can be changed by swapping the wires from the RC-panel that are connected to the unlock A and Unlock B contacts, as well as Led A and Led B, respectively.

Potential control mode (Pulse switch in the OFF position) is when the control signal is applied to the Unlock A (B) input, the glass panels slide away in the selected direction during the entire holding signal time. Sending the control signal to the Stop input closes the sliding panels, thereby blocking the passage, regardless of the signals at the Unlock A (B) inputs.



ST-01 Speed gate

Potential mode is recommended when operating from the ACS controller.

Regardless of the selected control mode, PASS A or PASS B signals are generated when passing in one direction or the other. These signals can inform the ACS controller of the fact of passage.

Emergency opening of the passage lane is performed by removing a low-level signal from the Fire Alarm contact relative to the GND contact.

The product also features an additional "Automatic opening in the selected direction" mode (R1 switch in the ON position). This is a mode of free passage through the turnstile in one pre-selected direction (selected by the R2 switch) with automatic opening and closing of the panels during passage.

Training mode (R1 switch in the OFF position, and R2 switch on the ST-01.771 control board in the ON position) allows manually adjusting the home (closed) position of the turnstile swing panels.

Note

When operating the speed gate from the ACS controller, it is recommended to connect the RC-panel to the ACS controller.

The maximum allowed cable length from the RC-panel (ACS controller) is 40 meters.

The maximum allowed cable length from the power supply depends on its cross section and must be:

- for 1.5 mm² cable – 10 meters
- for 2.5 mm² cable – 20 meters

Example of connection to the ACS

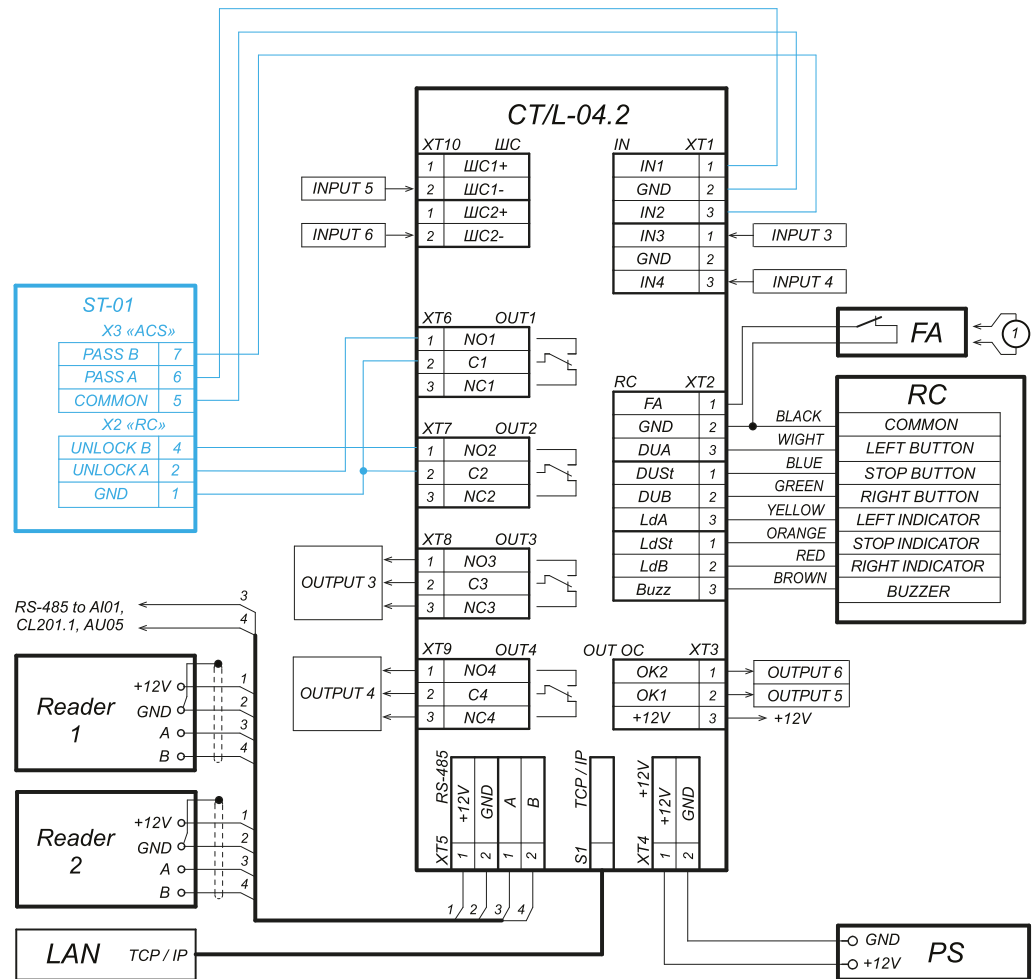

1 - jumper wire, installed when there is no FA device

A layout example of the speed gate connection to the ACS controller



Overall dimensions

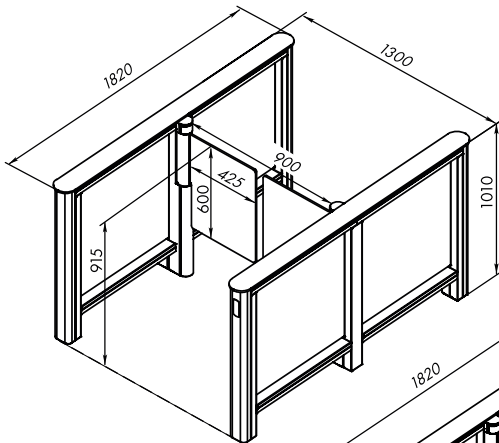

ATG-450 swing panels

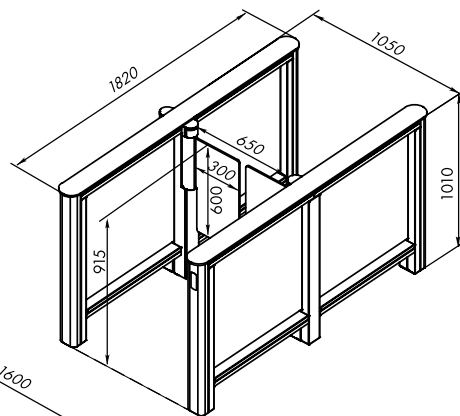

ATG-425 swing panels

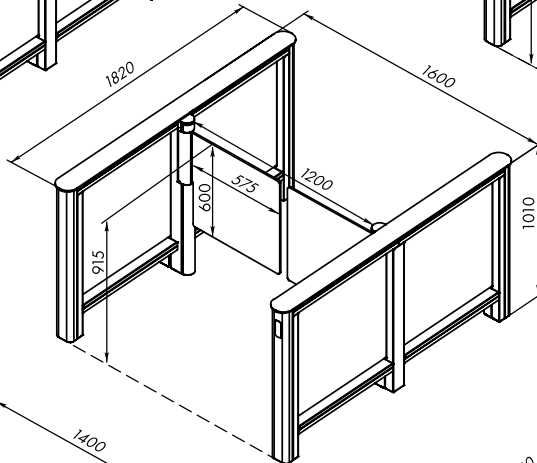

ATG-575 swing panels

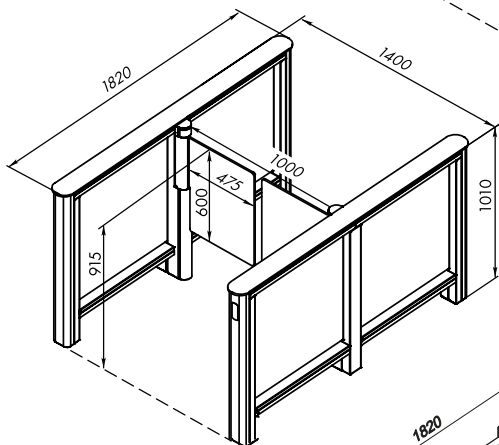

ATG-475 swing panels

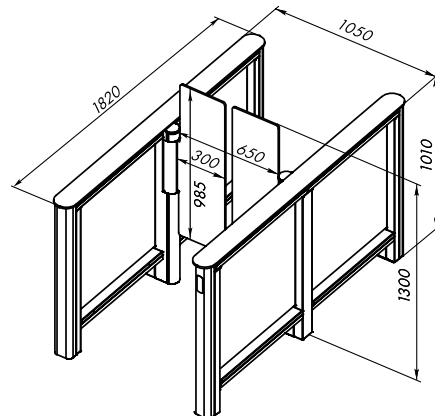

ATG-425H swing panels

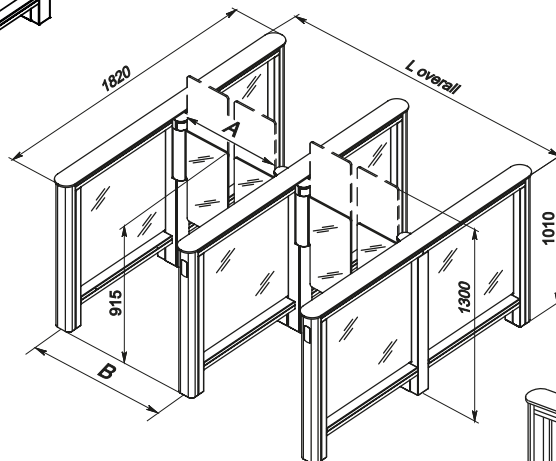

With STD-01 central section

for ATG-300 -A=650, 8=920;
for ATG-300H -A=650, 8=920;
for ATG-425 -A=900, 8=1170;
for ATG-475 -A=1000, 8=1270;
for ATG-575 -A=1200, 8=1470

$L_{overall} = 920n + 1170m + 1270k + 130$ (mm),
n - number of ATG-300 (ATG-300H),
m - number of ATG-425,
k - number of ATG-475,
p - number of ATG-575

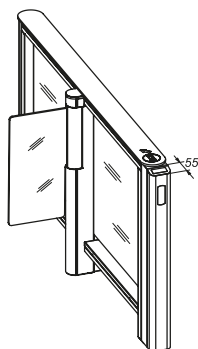

With FP-01Q, FP-01A front panel

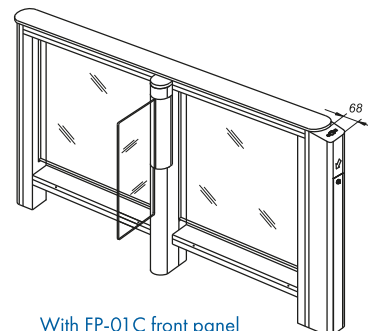

With FP-01C front panel

Overall dimensions



ST-01 Speed gate

Mounting

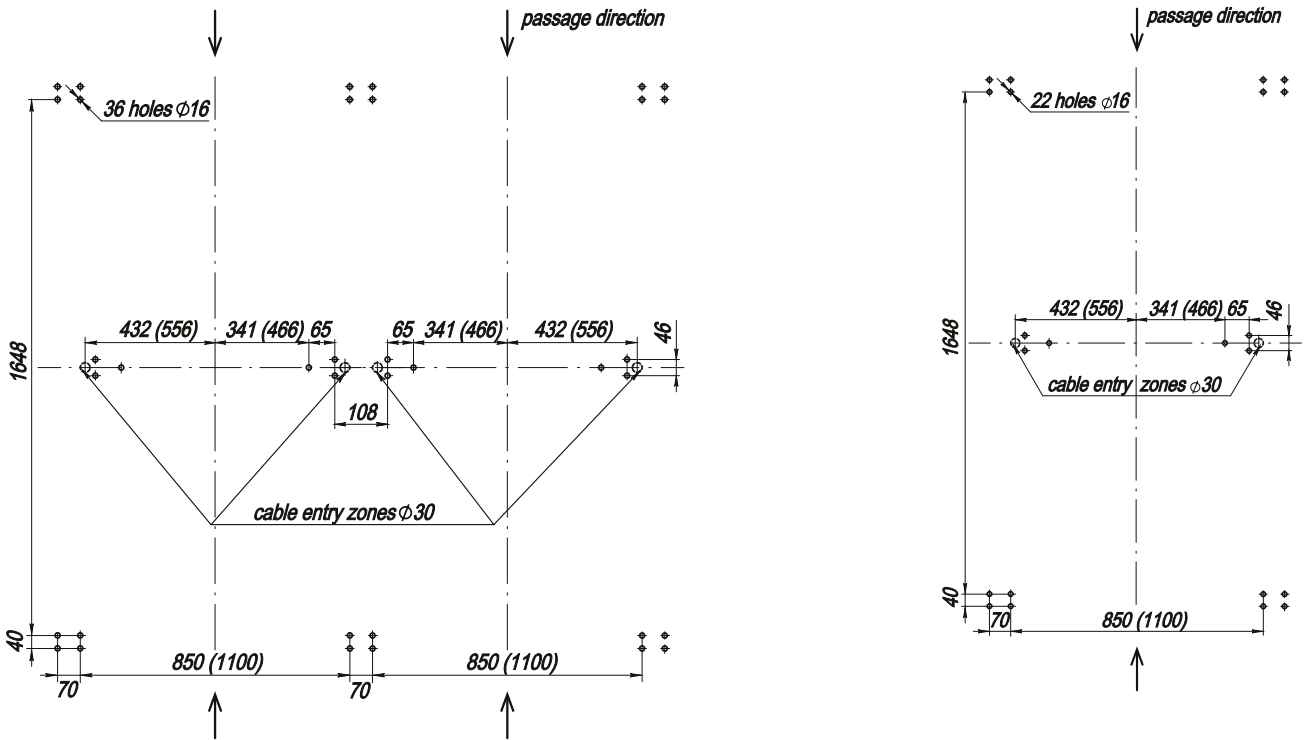

Hole marking for sections mounting and cable entry zone

Foundation requirements: concrete (grade 400 or higher), stone, etc. foundation of at least 150 mm thick, use reinforcing elements (450x450x200 mm) when installing sections on a less steady foundation.

Warranty

The warranty period is 5 (five) years commencing from the date of sale, unless otherwise determined in the delivery contract of the Product. In case of sale and installation of the equipment by authorized PERCo dealers and service centers, the warranty starts from the date of commissioning.

Should there be no date of sale on the warranty card, the warranty period shall commence from the date of manufacture specified in the Certificate and on the Product label.

TTR-10A Motorized tripod turnstile with automatic anti-panic barrier arms for outdoor application

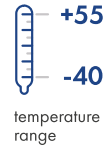

temperature range



operating voltage



Anti-panic barrier arms



passage direction



motor drive



persons/min

Application

TTR-10A Motorized tripod turnstile with automatic anti-panic barrier arms is designed for use in paid access systems, including transport, and at entrances of enterprises.

The main features of the TTR-10A tripod turnstile are the electric drive of the barrier arm rotation during the passage, automatic anti-panic barrier arms that fold down at a signal from an emergency unlocking device, or at a power loss, and stainless-steel housing.

The delivery set includes an RC-panel; the orientation of the RC-panel buttons relative to the directions of passage is set when connecting to the turnstile. The turnstile provides the passage control in two directions; the turnstile operating mode may be set independently for each passage direction.

It is recommended to install one turnstile per 500 people working the same shift, and based on a maximum working load of 30 persons/min. Turnstiles can be equipped with railings. The turnstile provides passage control in two directions, a turnstile operating mode may be set independently for each.



For transport



For wall mounting



Automatic anti-panic function

Operating modes

Supported operating modes:

- passage denial
- single passage in one direction and passage denial in the other direction
- single passage in both directions
- free passage in one direction and passage denial in the other direction
- free passage in one direction and single passage in the other direction
- free passage in both directions

When the power is turned off, the turnstile barrier arm falls down under its own weight, and both directions become open for free passage

Main features

- operation of the turnstile from RC-panel, WRC, ACS
- possibility of installation in the vehicle interior on vertical handrails (pipes) (TTR-10AT), on a vertical wall (TTR-10AK) or on the floor (TTR-10AB)



TTR-10A Motorized tripod turnstile with automatic anti-panic barrier arms for outdoor application

- possibility of outdoor application
- built into the turnstile housing electronic boards
- safe voltage – max. 29 V; power consumption – 150 W (maximum value of 260 W can only be reached for a short period of time in some states of the turnstile, the rest of the time power does not exceed 15 W)
- to power the turnstile, a power supply of at least 5.5 A is needed; when the emergency unlocking device sends a command, as well as when the power is turned off, the passage is automatically opened by switching the barrier arm to the vertical position
- after restoring the supply voltage or removing the Fire Alarm signal the barrier arm is moved to the working position manually
- electric drive provides automatic easy rotation of the barrier arms to the home position during the passage
- smooth silent operation of the turnstile electric drive
- the drive features a high-precision sensor (encoder) that correctly detects the barrier arms position
- possibility to connect an intrusion detector and a siren to the turnstile
- two control modes – pulse and potential
- galvanically isolated outputs
- Fire Alarm control input that allows connecting the emergency unlocking device
- relay outputs for connecting additional external indicators of the passage grant / denial

Design

Turnstile housing – stainless steel with a polycarbonate insert. Barrier arms – stainless steel.

Operating conditions

The turnstile, with regard to resistance to environmental exposure, complies with GOST 15150-69 category NF4 (operation outdoors). The operation of the turnstile is allowed at ambient temperature from -40° C to +50° C (when used under a canopy up to +55° C) and relative humidity of up to 80% at +25° C.

It is a serially produced product certified for compliance with applicable Russian and European CE standards.

Delivery set

Turnstile housing with ready-mounted cover	1
Hub with barrier arms and mounting kit	1
RC-panel (cable length of at least 6.6 m)	1
MT10.1 or MT10.2 mounting bracket or MT10.3 mounting post	1
Mounting kit	1
Documentation set	1
Optional equipment (upon request)	
WRC (consisting of a receiver and two transmitters in the form of key fobs) with a range of up to 40 m	1
Intrusion detector (installed upon request at the manufacturing site)	1
Siren (alert on an unauthorized passage attempt)	1
Turnstile power supply	1

Technical specifications

Operating voltage	22V–29V DC	
Current consumption	max. 5.5 A	
Power consumption	max. 150 W	
Overall dimensions (LxWxH)	TTR-10AT	613x806x746 mm
	TTR-10AK	613x806x714 mm
	TTR-10AB	1055x806x762 mm
Passageway width	500 mm	



Turnstile weight	TTR-10AB	max. 55 kg
Throughput in single passage mode		30 persons / min
Throughput in free passage mode		60 persons / min
IP Code		IP54
Vandal resistance		IK09
Vibration resistance		M28 and M29
Mean time to failure		3,000,000 passages
Mean lifetime		8 years

Connection

The TTR-10A turnstile features two built-in electronic boards – a control board and an interface board. The power supply is connected to the control board, and all other external connections are made to the interface board.

Built-in electronics contacts description by connectors			
Control board			
X1	1, 2	+24, GND	24V DC, 9A power supply connection of the turnstile
Interface board			
X1	1, 2	+12OUT, GND	+12V power supply connection of optional equipment (sirens)
	3, 4	A1, A2	Alarm system connection (sirens)
	5	C	Common for A1, A2, Pass A, Pass B contacts
	6	Pass A	PASS A relay contact (passage in the direction A)
	7	Pass B	PASS B relay contact (passage in the direction B)
X2	1	GND	Common for RC-panel (WRC, ACS)
	2, 3, 4	L, ST, R	Turnstile control inputs
	5, 6, 7, 8	Led A, Led ST, Led B, Sound	Light and sound indication outputs on the RC-panel
	9, 10	FA, GND	Emergency passage opening control input
X3	1, 2, 3	NO1, C1, NC1	Light A relay contacts – connection of a remote indicator for direction A (not included in the standard delivery set)
	5, 6, 7	NO2, C2, NC2	Light B relay contacts – connection of a remote indicator for direction B (not included in the standard delivery set)
X4	1	+12OUT	+12V power supply connection for optional equipment (intrusion detector)
	2, 3, 4	DKZP1, DKZP2, GND	Intrusion detector connection
X5	5	COM	Common for DETECT and READY signals
	6	DETECT	Det Out relay output (intrusion detector status)
	7	READY	Ready relay output (the turnstile availability)
X6	8, 9	LV1, LV2	Relay output for low-voltage signalling (the battery is low)



TTR-10A Motorized tripod turnstile with automatic anti-panic barrier arms for outdoor application

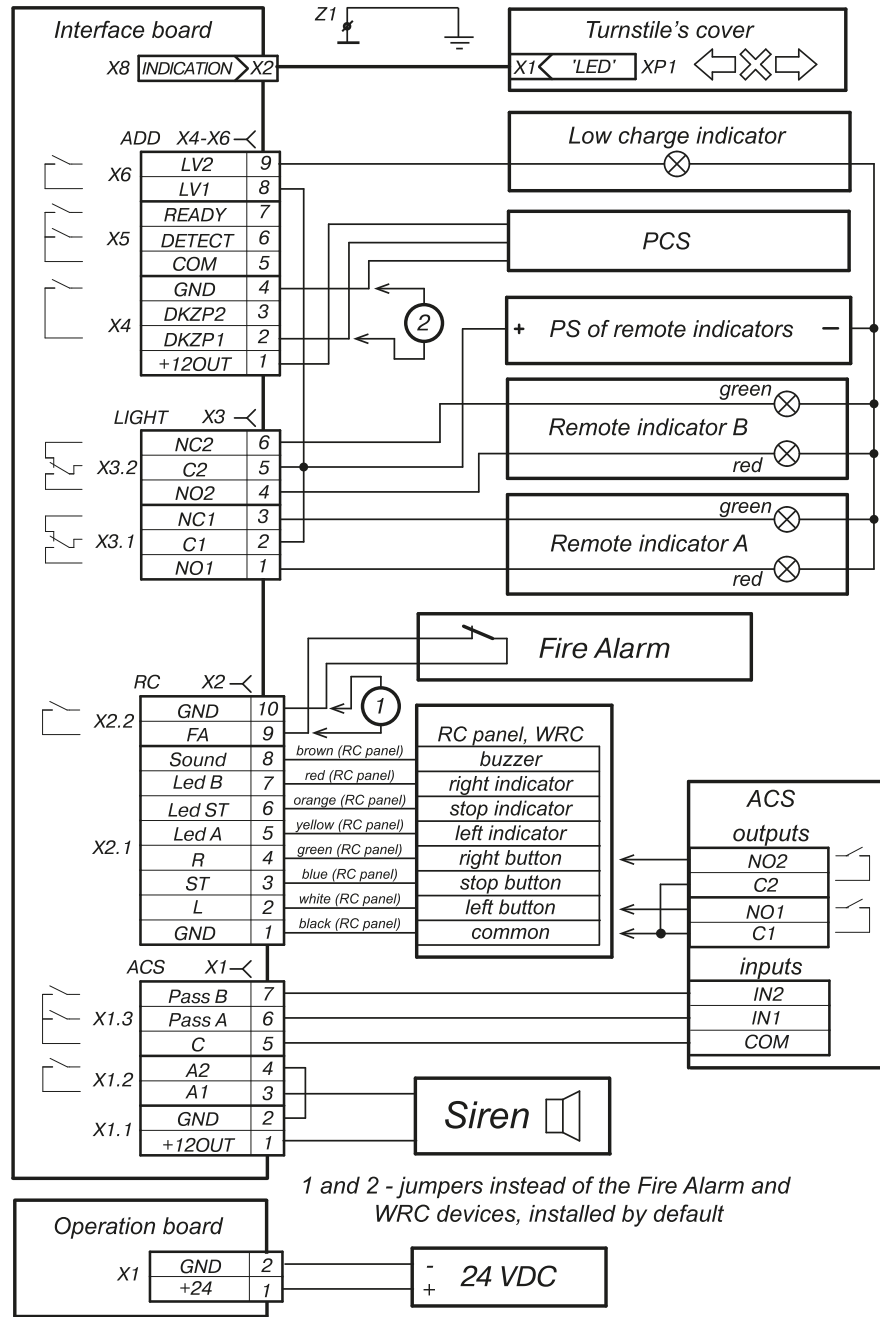

TTR-10A wiring diagram

Operation algorithm

The turnstile can operate from the RC-panel (included in the delivery set), WRC, or ACS controller. The turnstile is controlled by applying a low-level signal to the L, ST, and R contacts relative to the GND contact. The response to these signals depends on the control mode selected by the switch 1. Pulse control mode is when a pulse is applied to the L (R) input, the turnstile will automatically unlock for a single passage in the selected direction. The waiting time for the passage being completed does not depend on the duration of the control pulse and lasts 5 seconds. Sending pulse to the ST input locks both directions. Simultaneous sending of pulses to the L (R) and ST inputs places the turnstile in the "Free passage" mode in the selected direction. It is recommended to use pulse mode when operating from RC-panel or WRC. The orientation of RC-panel buttons (if the turnstile is facing the operator not with the front side, but with the back side) can be changed by swapping the wires from the RC-panel that are connected to the L and R, as well as Led A and Led B, respectively.

Potential control mode is when the control signal is applied to the L (R) input, the turnstile remains unlocked in the selected direction during the entire holding signal time. Sending the control signal to the ST input locks both passage directions regardless of the signals at the L (R) inputs.

Turnstiles, gates and railings

Potential mode is recommended when operating from the ACS controller. Regardless of the selected control mode, when the turnstile barrier arms are moved in one direction or the other, passage signals are generated – PASS A or PASS B respectively. These signals can inform the ACS controller of the fact of passage. Emergency passage opening is performed by removing a low-level signal from the Fire Alarm contact relative to the GND contact.

Note:

When operating the turnstile from the ACS controller, it is recommended to connect the RC-panel to the ACS controller. The maximum allowed cable length of the RC-panel (ACS controller) is 40 meters. The maximum allowed cable length of the power supply depends on its cross section and must be:

- for 2.5 mm² cable – 15 meters

Example of connection to the ACS

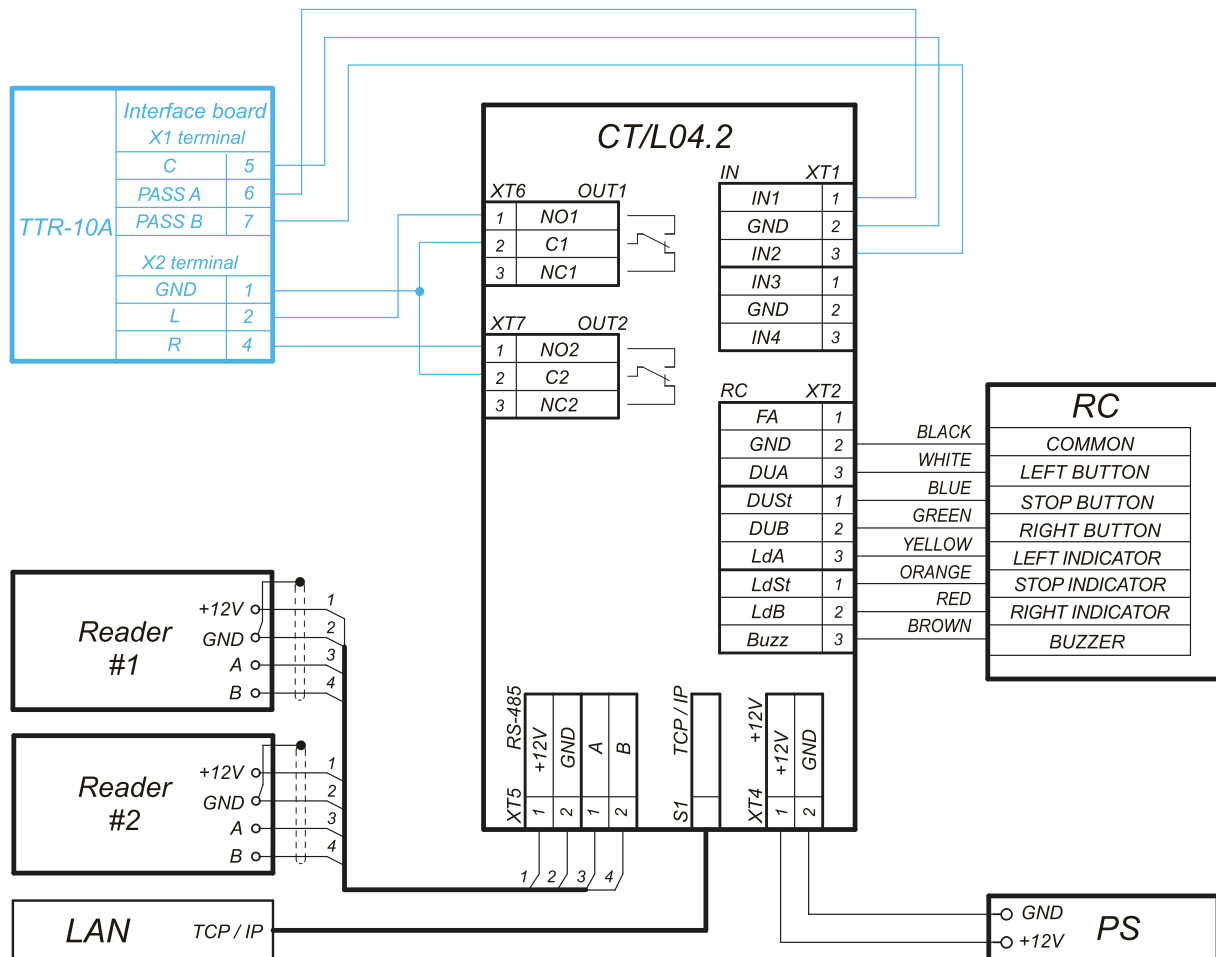

A layout example of the turnstile connection to the ACS controller



TTR-10A Motorized tripod turnstile with automatic anti-panic barrier arms for outdoor application

Overall dimensions

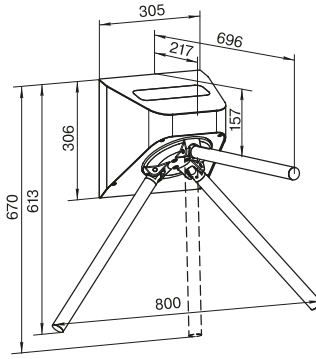

Overall turnstile dimensions without mounting bracket (mounting post)

Mounting

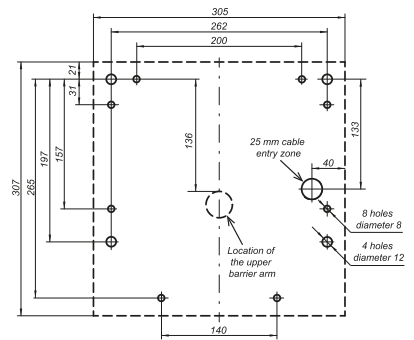
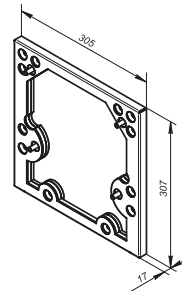
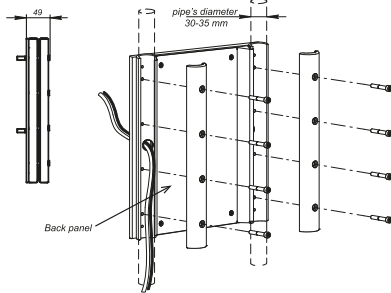
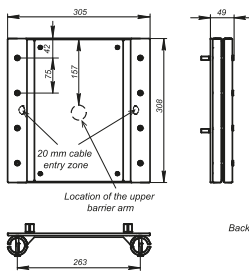

MT10.1 mounting bracket, dimensions and mounting procedure on pipes

MT10.2 mounting bracket, dimensions and hole marking on the wall

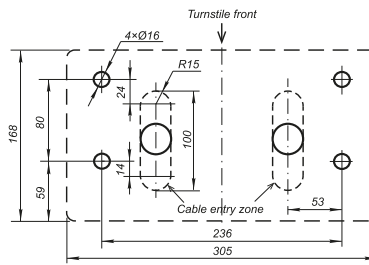
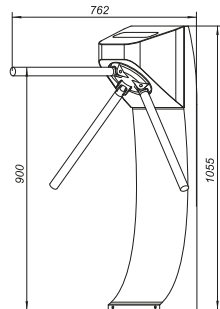

MT10.3 mounting post, dimensions and hole marking on the floor

Passage zone modeling

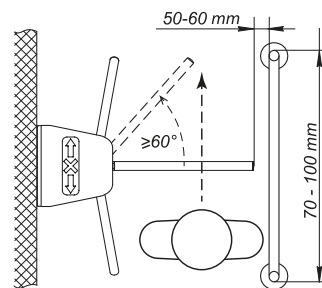

Turnstile top view

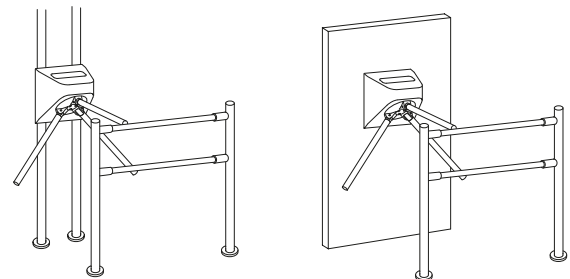

Example of an entrance zone project

Warranty

The warranty period is 5 (five) years commencing from the date of sale, unless otherwise determined in the delivery contract of the Product. In case of sale and installation of the equipment by authorized PERCo dealers and service centers, the warranty starts from the date of commissioning. Should there be no date of sale on the warranty card, the warranty period shall commence from the date of manufacture specified in the Certificate and on the Product label.

TTR-08A Tripod turnstile with automatic anti-panic barrier arms for outdoor application



+55
-20
temperature range

12V
operating voltage

anti-panic barrier arms

2
passage direction

72W
power consumption

30
persons/min

Application

TTR-08A tripod turnstile with automatic anti-panic barrier arms is designed for outdoor and indoor applications.

The main features of the TTR-08A tripod turnstile are automatic anti-panic barrier arms that fold down at a signal from an emergency unlocking device or at a power loss, possibility to install built-in proximity readers, dynamic passage indication, and stainless-steel housing.

The delivery set includes an RC-panel, the orientation of the RC-panel buttons relative to the passage directions is set when connecting to the turnstile.

It is recommended to install one turnstile per 500 people working the same shift, and on the basis of maximum working load of 30 persons/min. Turnstiles can be equipped with railings.



Automatic anti-panic barrier arms



RC-panel

Operating modes

The turnstile provides passage control in two directions; turnstile operating mode may be set independently for each passage direction.

Supported operating modes:

- passage denial in both directions
- single passage in one direction and passage denial in the other direction
- single passage in both directions
- free passage in one direction and passage denial in the other direction
- free passage in one direction and single passage in the other direction
- free passage in both directions

When the power is turned off, the turnstile barrier arm falls down, and both directions become open for free passage.

Main features

- operation of the turnstile from RC-panel, WRC, ACS
- possibility of outdoor installation under a canopy
- built-in electronic board



TTR-08A Tripod turnstile with automatic anti-panic barrier arms for outdoor application

- safe voltage – max. 14 V
- power consumption - max. 72 W (maximum value of 72 W – within 5 seconds after powering the turnstile or removing the Fire Alarm signal; the power consumption is max. 30 W during the rest of the operation)
- to power the turnstile, a power supply of at least 6 A is needed for 5 seconds
- when a command is given by the emergency unlocking device, as well as when the turnstile power supply is turned off, the passage opens automatically by moving the barrier arm to the vertical position
- after restoring the turnstile supply voltage or removing the Fire Alarm signal, the barrier arm is moved to the working position manually
- automatic reset of the barrier arms to the home position after each passage
- damping device provides smooth silent operation
- barrier arm rotation optical sensors record correctly the fact of passage
- built-in dynamic indication of operating modes on the turnstile front and side panels
- possibility to install built-in proximity readers
- reader interrogation zones are indicated with backlit pictograms
- possibility to connect an intrusion detector and a siren to the turnstile
- two control modes – pulse and potential
- galvanically isolated outputs
- Fire Alarm control input that allows connecting the emergency unlocking device
- relay outputs for connecting additional remote indicators of the passage grant / denial

Design

Turnstile housing – stainless steel with ABS plastic inserts.
Barrier arms – stainless steel.

Operating conditions

TTR-08A, with regard to resistance to environmental exposure, complies with GOST 15150 category NF4 (operation outdoors). The operation of the turnstile is allowed at ambient temperature from -20° C to +55° C and relative humidity of up to 80% at +25° C. It is a serially produced product certified for compliance with applicable Russian and European CE standards.

Delivery set

Turnstile housing with built-in electronic board	1
Hub with barrier arms and mounting kit	1
RC-panel (cable length of at least 6.6 m)	1
Mounting kit	1
Documentation set	1
Optional equipment (upon request)	
WRC (consisting of a receiver and two transmitters in the form of key fobs) with a range of up to 40 m	1
Intrusion detector (installed upon request at the manufacture site)	1
Siren (for signaling that an unauthorized passage has been attempted)	1
PFG IR 10-15 anchor (SORMAT company, Finland)	4
Turnstile power supply	1



Technical specifications

Operating voltage	12±1.2 V DC
Current consumption	max. 6 A
Power consumption	max. 72 W
Overall dimensions with installed barrier arms (LxWxH)	798x777x1084 mm
Passageway width	500 mm
Turnstile weight	45 kg
Package dimensions	119x45x42 cm
Throughput in single passage mode	30 persons / min
Throughput in free passage mode	60 persons / min
Mean time to failure	4,000,000 passages
Mean lifetime	8 years

Connection

TTR-08A turnstile is equipped with an integrated CLB.140 electronic board. All connections are made to the board contacts. The microcontroller installed on the board controls the turnstile's actuating mechanism, processes signals from optical sensors for moving the barrier arms, processes commands received from external devices, and generates signals about passages through the turnstile.

Built-in electronic board contacts description by connectors			
Connector	Contact	Electrical circuit	Designation
XT1.L	1, 2, 3	+12 V, Detector, GND	Intrusion detector connection
	4, 5	Fire Alarm, GND	Emergency unlocking input
	6	GND	Power supply negative terminal
	7, 8, 9	Unlock A, Stop, Unlock B	Turnstile control inputs
	10, 11, 12	Led A, Led Stop, Led B	RC-panel indication outputs
XT1.H	1	GND	Power supply negative terminal
	2	+12 V	"Siren" device power supply positive terminal
	3, 4	Alarm 1, Alarm 2	Alarm relay contacts
	5	Common	Common contact for PASS A, PASS B, Ready, Det Out signals
	6	PASS A	PASS A relay contact (passage in the direction A)
	7	PASS B	PASS B relay contact (passage in the direction B)
	8	Ready	Ready relay contact
	9	Det Out	Det Out relay contact
	XT3	1, 2	+12 V, GND
XT4	1, 2, 3	NO, C, NC	Light A relay contacts – connection of a remote indicator for direction A (not included in the standard delivery set)
XT5	1, 2, 3	NO, C, NC	Light B relay contacts – connection of a remote indicator for direction B (not included in the standard delivery set)
XT6	1, 2	"L+", "L-"	AntiPanic relay contacts for connecting the electromagnet of the automatic anti-panic function device.
X1		LED	X1 (LED) connector for connecting the indication board cable
X2		SENS	X2 (SENS) connector for connecting the rotation optical sensor unit cable
X3		MOTOR	X3 (MOTOR) connector for connecting the control mechanism cable with an electromechanical locking device



TTR-08A Tripod turnstile with automatic anti-panic barrier arms for outdoor application

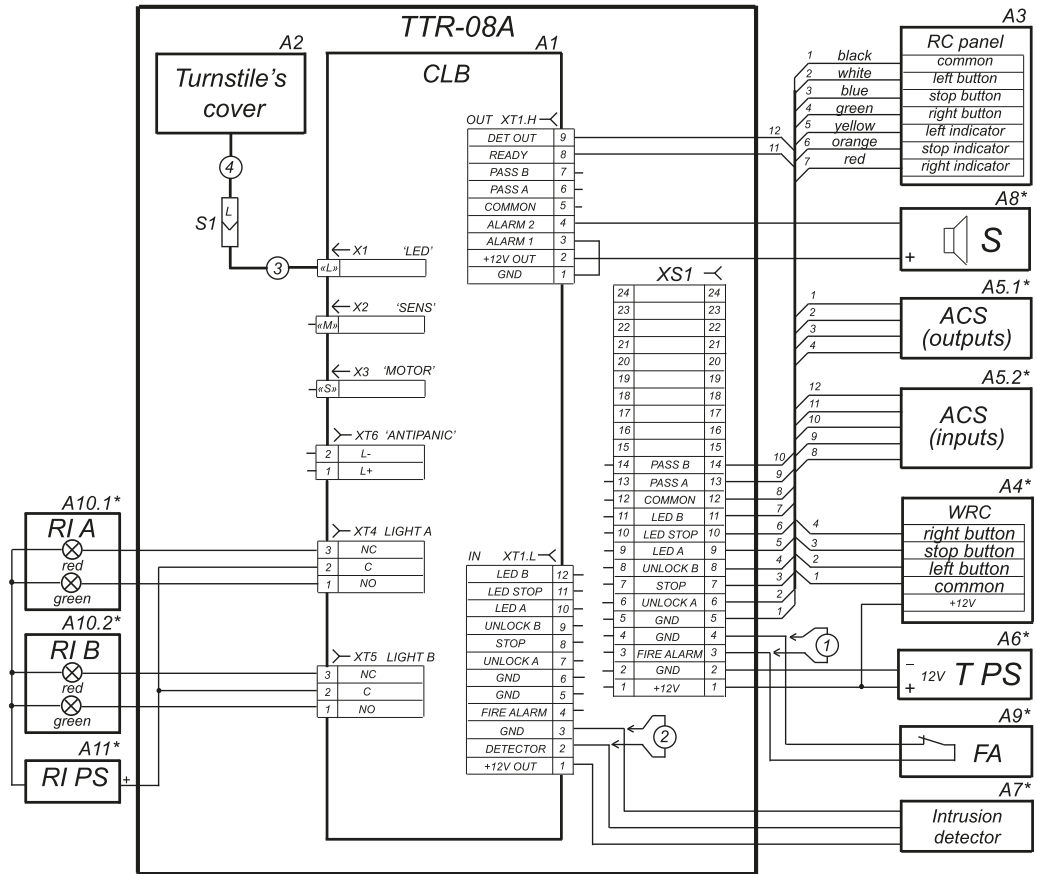

Wiring diagram of external connections to the CLB Board

Diagram description	
ITEM	DESCRIPTION
A1	CLB.140 control board
A2	Turnstile cover with indication blocks
A3	H-06/4.100 RC-panel
A4*	WRC
A5*	Access control system
A6*	Turnstile power supply
A7*	Intrusion detector
A9*	Device that gives the emergency passage opening command (FA)
A10.1*, A10.2*	Remote indicators
A11*	Power supply for remote indicators
XS1	PSK1/12 (12) Klemmsan x 2 terminal block
S1	Connector for connecting the turnstile cover (A2)
1	Jumper wire if there is no FA device (A9)
2	Jumper wire if there is no intrusion detector (A7)
3	Control board indication cable
4	Turnstile cover indication cable

* The equipment is not included in the standard delivery set

Operation algorithm

The turnstile can operate from the RC-panel (included in the delivery set), WRC or ACS controller.

Operation is performed by applying a low-level signal to Unlock A, Stop and Unlock B contacts relative to the GND contact. The response to these signals depends on the control mode selected by the J1 jumper wire.

Pulse control mode is when a pulse is applied to the Unlock A (B) input, the turnstile will automatically open for a single passage in the selected direction. The waiting time for the passage being completed does not depend on the duration of the control pulse and lasts 5 seconds. Sending a pulse to the Stop input locks both passage directions. Simultaneous sending of pulses to Unlock A (B) and Stop inputs places the turnstile in the "Free passage" mode in the selected direction.

It is recommended to use pulse mode when operating from RC-panel or WRC. The orientation of RC-panel buttons (if the turnstile is facing the operator not with the front side, but with the rear side) can be changed by swapping the wires from the RC-panel that are connected to the Unlock A and Unlock B, as well as Led A and Led B, respectively.

Potential control mode is when the control signal is applied to the Unlock A (B) input, the turnstile remains unlocked in the selected direction during the entire holding signal time. Sending control signal to the Stop input locks both passage directions regardless of the signals at the Unlock A (B) inputs.

Potential mode is recommended during operation from the ACS controller.

Regardless of the selected control mode, PASS A or PASS B signals are generated when moving the barrier arms in one direction or the other. These signals can inform the ACS controller of the fact of passage.

Emergency passage opening is performed by removing a low-level signal from the Fire Alarm contact relative to the GND contact.

Note:

When operating the turnstile from the ACS controller, it is recommended to connect the RC-panel to the ACS controller.

The maximum allowed cable length of the RC-panel (ACS controller) is 50 meters.

The maximum allowed cable length of the power supply depends on its cross section and must be:

- for 1.5 mm² cable – 10 meters
- for 2.5 mm² cable – 15 meters



TTR-08A Tripod turnstile with automatic anti-panic barrier arms for outdoor application

Example of connection to the ACS

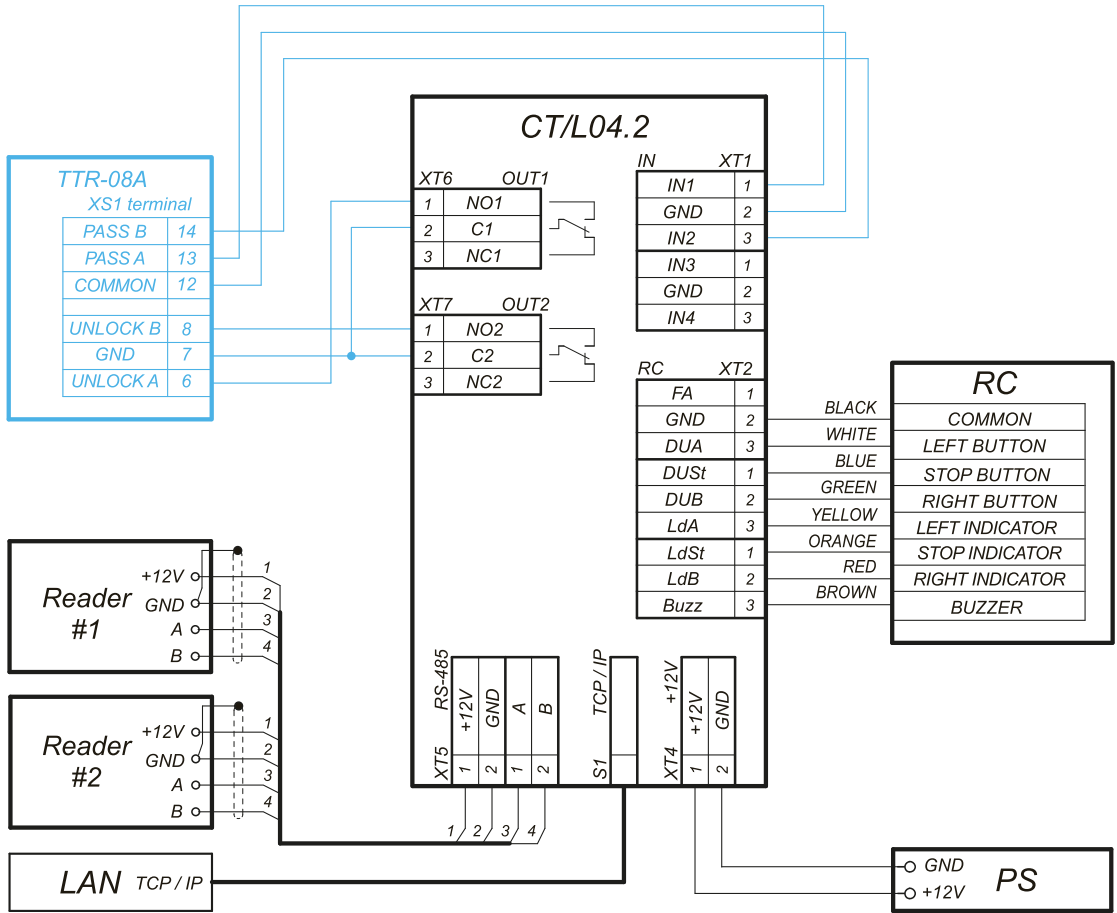

Example of connection to the ACS

Overall dimensions

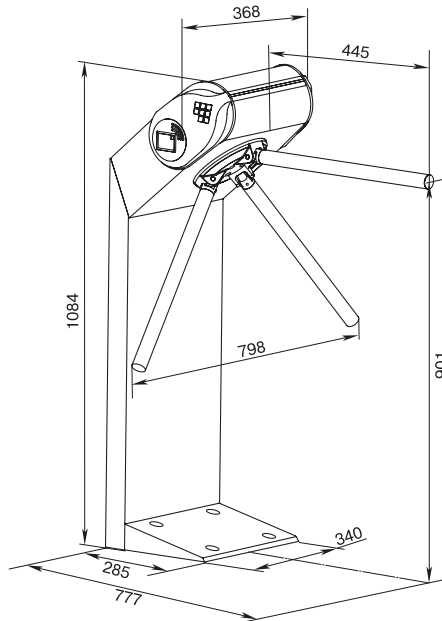

Overall dimensions



Mounting

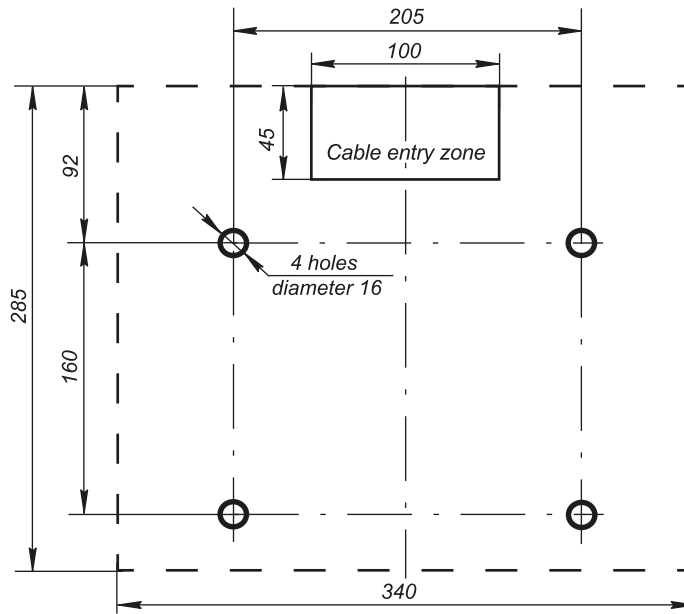

Hole marking for housing mounting and cable entry zone (110x55)

Foundation requirements: concrete (not lower than 400 grade), stone, etc. foundation of at least 150 mm thick, use reinforcing elements (400x400x300 mm) when installing turnstile housing on a less steady foundation.

Passage zone modeling

When the turnstile is operated from ACS, it is recommended to place card readers in the turnstile housing or on the railings that form the passage zone. BH01 0-03 bracket is used for mounting readers on the BH02 series railings.

Passage zone modeling of the TTR-08 turnstile is similar to the TTR-07.1 or TTR-04.1 tripod turnstiles.

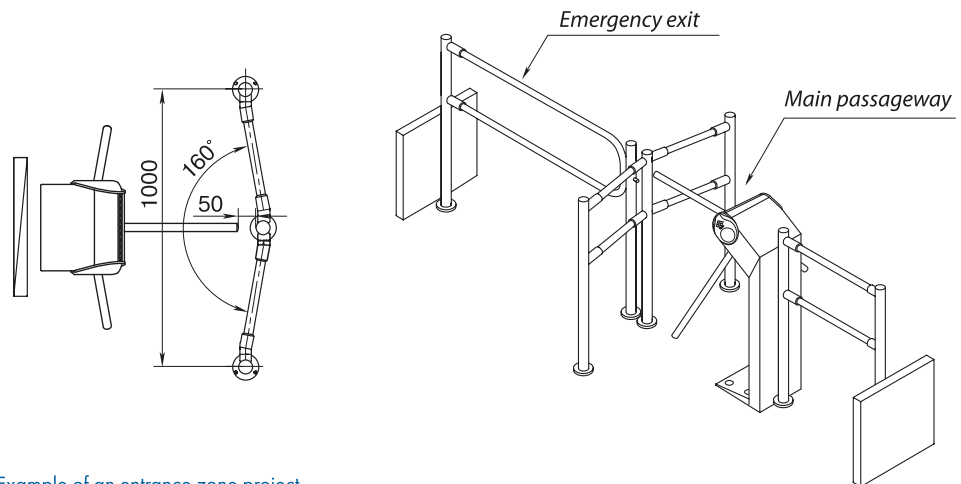

Example of an entrance zone project

Warranty

The warranty period is 5 (five) years commencing from the date of sale, unless otherwise determined in the delivery contract of the Product. In case of sale and installation of the equipment by authorized PERCo dealers and service centers, the warranty starts from the date of commissioning.



TTR-07.1 Tripod turnstile with automatic anti-panic barrier arms



+50
+1
temperature range

12V
operating voltage

anti-panic barrier arms

2
passage direction

72W
power consumption

30
persons/min

Turnstiles, gates and railings

Application

TTR-07.1 tripod turnstile with automatic anti-panic barrier arms is designed for indoor applications. The main feature of the TTR-07.1 turnstile is automatic anti-panic barrier arms that fold down at a signal from an emergency unlocking device or at a power loss which provides free passage in case of emergency.

The delivery set includes an RC-panel, the orientation of the RC-panel buttons relative to the passage directions is set when connecting to the turnstile. It is recommended to install one turnstile per 500 people working the same shift based on a maximum working load of 30 persons/min. Turnstiles can be equipped with railings.



Automatic anti-panic barrier arms



RC-panel

Operating modes

The turnstile provides passage control in two directions; the turnstile operating mode may be set independently for each passage direction.

Supported operating modes:

- passage denial in both directions
- single passage in one direction and passage denial in the other direction
- single passage in both directions
- free passage in one direction and passage denial in the other direction
- free passage in one direction and single passage in the other direction
- free passage in both directions

When the power is turned off, the turnstile barrier arm falls down, and both directions become open for free passage.

Main features

- operation of the turnstile from RC-panel, WRC, ACS
- built-in electronic board
- safe voltage – max. 14 V

Turnstiles, gates and railings



- power consumption - max. 72 W (maximum value of 72 W – within 5 seconds after powering the turnstile or removing the Fire Alarm signal; the power consumption is max. 30 W during the rest of the operation)
- to power the turnstile, a power supply of min. 6 A is needed for 5 seconds
- when a command is given by the emergency passage opening device, as well as when the turnstile power supply is turned off, the passage opens automatically by moving the barrier arm to the vertical position
- after restoring the turnstile supply voltage or removing the Fire Alarm signal, the barrier arm is moved to the working position manually
- automatic reset of the barrier arms to the home position after each passage
- damping device provides smooth silent operation
- barrier arm rotation optical sensors record correctly the fact of passage
- built-in indication of operating modes
- possibility to connect an intrusion detector and a siren to the turnstile
- two control modes – pulse and potential
- galvanically isolated outputs
- Fire Alarm control input that allows connecting the emergency unlocking device
- relay outputs for connecting additional remote indicators of the passage grant / denial



Pictogram indication block

Design

Housing – powder coated steel. Colour – dark grey with pearl mica effect.
Barrier arms – stainless steel.

Operating conditions

The turnstile, with regard to resistance to environmental exposure, complies with GOST 15150-69 category NF4 (operation in premises with climate control).

Operation of the turnstile is allowed at ambient temperature from +1 °C to +50 °C and relative air humidity up to 80% at + 25 °C (non-condensing).

It is a serially produced product certified for compliance with applicable Russian and European CE standards.

Delivery set

Turnstile housing with built-in electronic board	1
Hub with barrier arms and mounting kit	1
RC-panel (cable length of min. 6.6 m)	1
Mounting kit	1
Documentation set	1
Optional equipment (upon request)	
WRC (consisting of a receiver and two transmitters in the form of key fobs) with a range of up to 40 m	1
Intrusion detector (installed upon request at the manufacturing site)	1
Siren (alert on an unauthorized passage attempt)	1
PFG IR 10-15 anchor (SORMAT company, Finland)	4
Turnstile power supply	1

Technical specifications

Operating voltage	12±1.8 V DC
Current consumption	max. 6 A
Power consumption	max. 72 W



TTR-07.1 Tripod turnstile with automatic anti-panic barrier arms

Overall dimensions with installed barrier arms (LxWxH)	798x752x1054 mm
Passageway width	530 mm
Turnstile weight	38 kg
Package dimensions	114x32x32 cm
Throughput in single passage mode	30 persons / min
Throughput in free passage mode	60 persons / min
Mean time to failure	4,000,000 passages
Mean lifetime	8 years

Connection

TTR-07.1 is equipped with integrated CLB.140 electronic board. All connections are made to the board contacts. The microcontroller installed on the board controls the turnstile's actuating mechanism, processes signals from optical sensors for moving the barrier arms, processes commands received from external devices, and generates signals about passages through the turnstile.

Built-in electronic board contacts description by connectors

Connector	Contact	Electrical circuit	Designation
XT1.L	1, 2, 3	+12 V, Detector, GND	Intrusion detector connection
	4, 5	Fire Alarm, GND	Emergency unlocking input
	6	GND	Power supply negative terminal
	7, 8, 9	Unlock A, Stop, Unlock B	Turnstile control inputs
	10, 11, 12	Led A, Led Stop, Led B	RC-panel indication outputs
XT1.H	1	GND	Power supply negative terminal
	2	+12 V	"Siren" device power supply positive terminal
	3, 4	Alarm 1, Alarm 2	Alarm relay contacts
	5	Common	Common contact for PASS A, PASS B, Ready, Det Out signals
	6	PASS A	PASS A relay contact (passage in the direction A)
	7	PASS B	PASS B relay contact (passage in the direction B)
	8	Ready	Ready relay contact
	9	Det Out	Det Out relay contact
	XT3	1, 2	+12 V, GND
XT4	1, 2, 3	NO, C, NC	Light A relay contacts – connection of the remote indicator for direction A (not included in the standard delivery set)
XT5	1, 2, 3	NO, C, NC	Light B relay contacts – connection of the remote indicator for direction B (not included in the standard delivery set)
XT6	1, 2	"L+", "L-"	AntiPanic relay contacts for connecting electromagnet of the automatic anti-panic function device
X1		LED	X1 (LED) connector for connecting indication board cable
X2		SENS	X2 (SENS) connector for connecting rotation optical sensor unit cable
X3		MOTOR	X3 (MOTOR) connector for connecting control mechanism cable with an electromechanical locking device

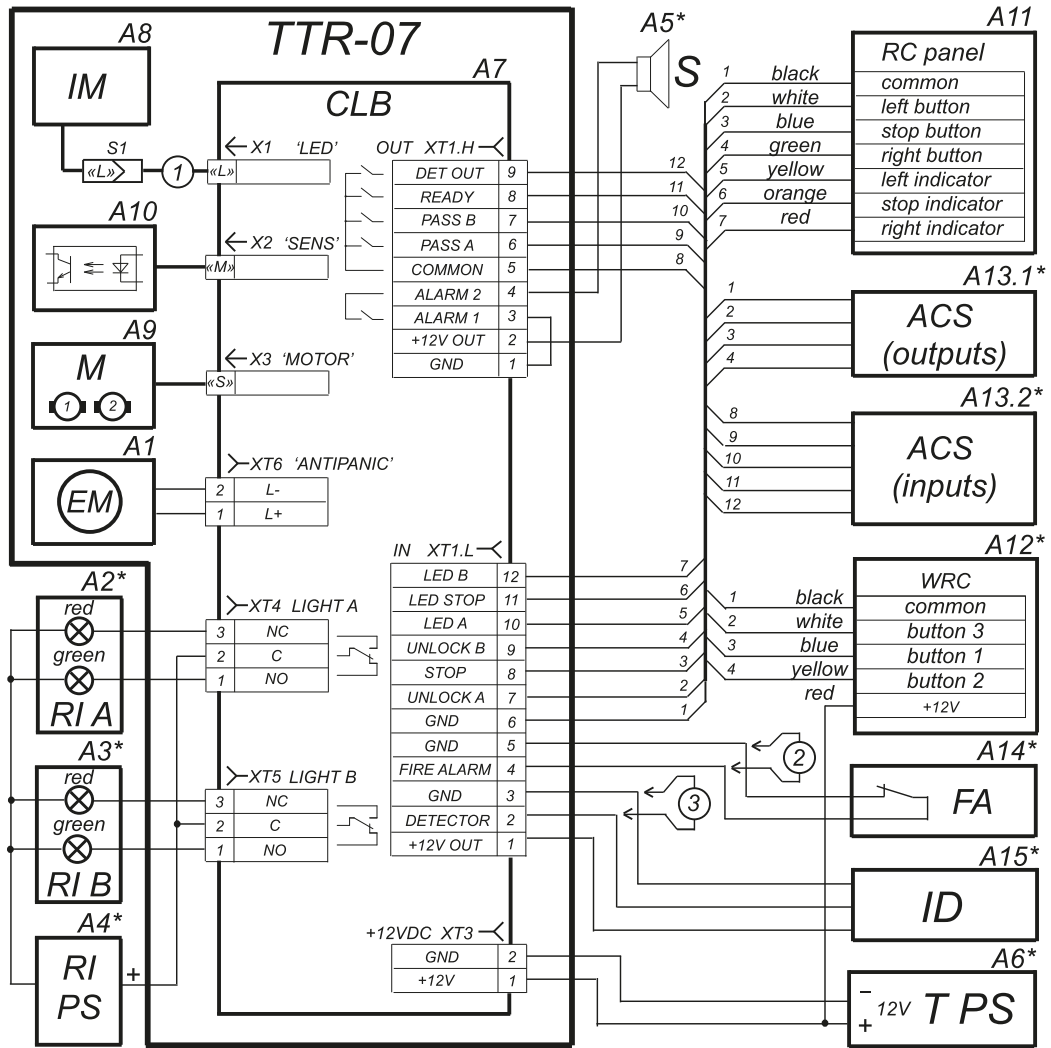

Wiring diagram of external connections to the CLB.2 board

Diagram description	
ITEM	Description
A1	Electromagnet
A2*, A3*	Remote indicator
A4*	Power supply for remote indicators
A5*	12V DC siren
A6*	Turnstile power supply
A7	CLB.140 board
A8	Indication board
A9	Electric motor
A10	Rotation sensor unit
A11	RC-panel
A12*	WRC
A13*	Access control system
A14*	Device that gives an emergency passage opening command
A15*	Intrusion detector
1	indication cable

* The equipment is not included in the standard delivery set



TTR-07.1 Tripod turnstile with automatic anti-panic barrier arms

Operation algorithm

The turnstile can operate from the RC-panel (included in the delivery set), WRC or ACS controller. Operation is performed by applying a low-level signal to Unlock A, Stop and Unlock B contacts relative to the GND contact. The response to these signals depends on the control mode selected by the J1 jumper wire.

Pulse control mode is when a pulse is applied to the Unlock A (B) input, the turnstile will automatically open for a single passage in the selected direction. The waiting time for the passage being completed does not depend on the duration of the control pulse and lasts 5 seconds. Sending a pulse to the Stop input locks both passage directions. Simultaneous sending of pulses to Unlock A (B) and Stop inputs places the turnstile in the "Free passage" mode in the selected direction.

It is recommended to use pulse mode when operating from RC-panel or WRC. The orientation of RC-panel buttons (if the turnstile is facing the operator not with the front side, but with the rear side) can be changed by swapping the wires from the RC-panel that are connected to the Unlock A and Unlock B, as well as Led A and Led B, respectively.

Potential control mode is when the control signal is applied to the Unlock A (B) input, the turnstile remains unlocked in the selected direction during the entire holding signal time. Sending control signal to the Stop input locks both passage directions regardless of the signals at the Unlock A (B) inputs.

Potential mode is recommended during operation from the ACS controller.

Regardless of the selected control mode, PASS A or PASS B signals are generated when moving the barrier arms in one direction or the other. These signals can inform the ACS controller of the fact of passage.

Emergency passage opening is performed by removing a low-level signal from the Fire Alarm contact relative to the GND contact.

Note:

When operating the turnstile from the ACS controller, it is recommended to connect the RC-panel to the ACS controller.

The maximum allowed cable length of the RC-panel (ACS controller) is max. 50 meters.

The maximum allowed cable length of the power supply depends on its cross section and must be:

- 1.5 mm² cable cross-section – 10 m;
- 2.5 mm² cable cross-section – 15 m.

Recommended cable type is 2x1.5 power cable.



Example of connection to the ACS

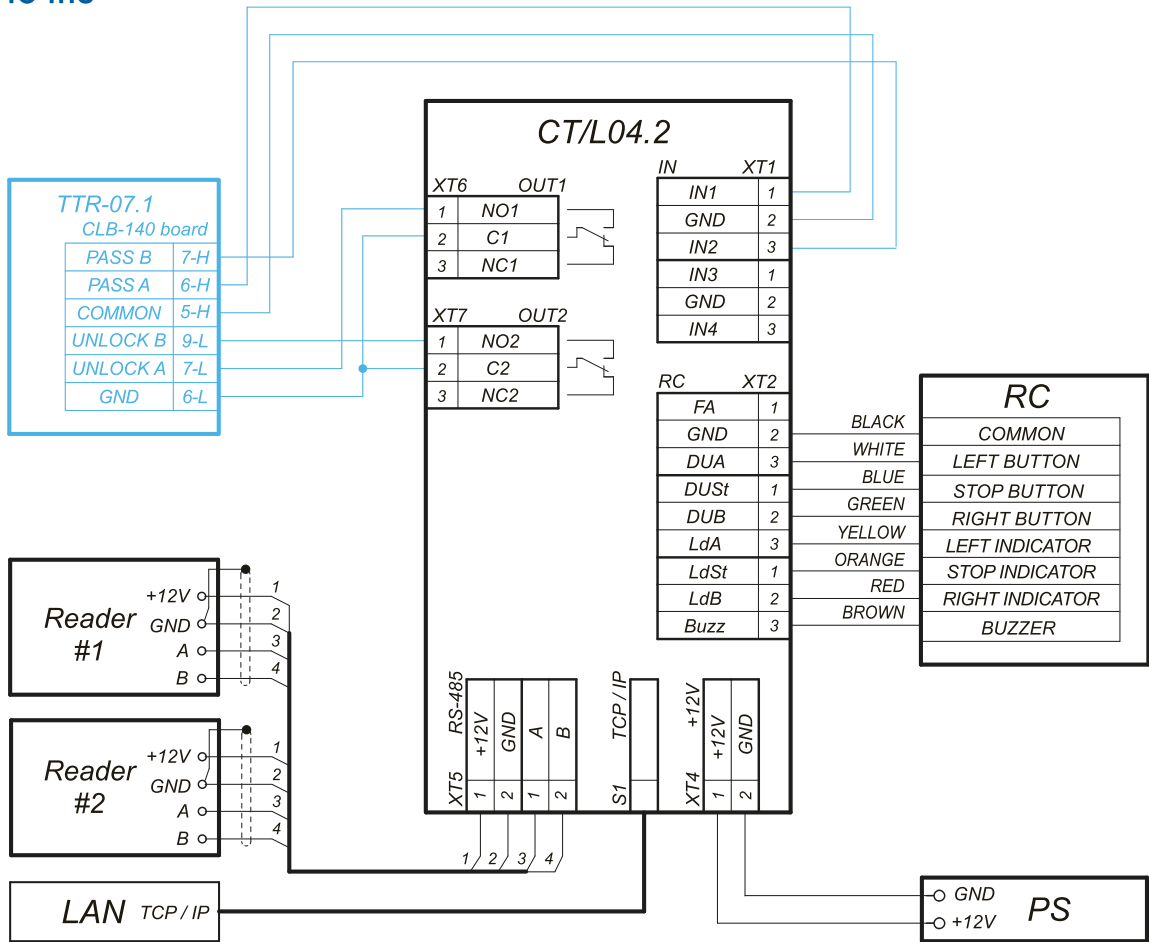

1 - jump wire when there is no Fire Alarm device

Example of turnstile connection to the ACS controller

Overall dimensions

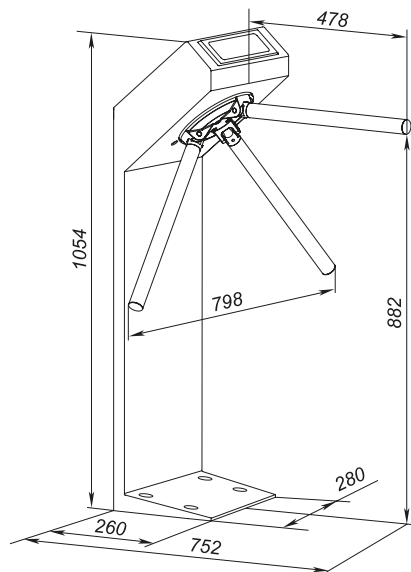

Overall dimensions



TTR-07.1 Tripod turnstile with automatic anti-panic barrier arms

Mounting

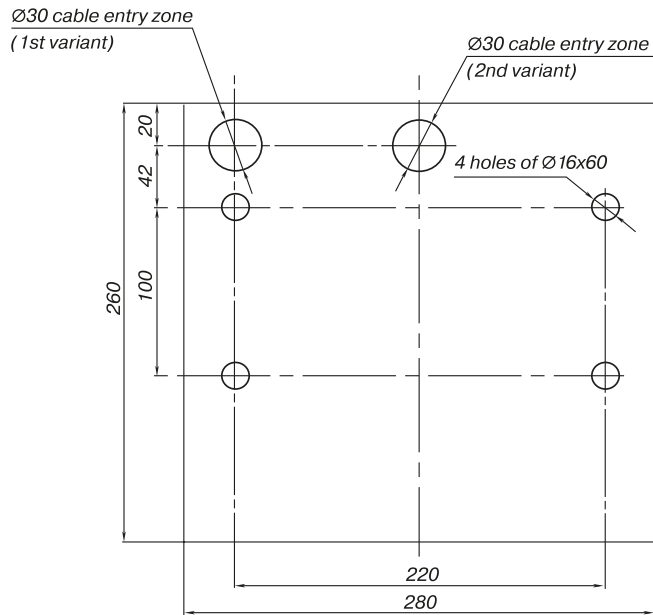

Hole marking for housing mounting and cable entry zone

Foundation requirements: concrete (not lower than 400 grade), stone, etc. foundation of at least 150 mm thick, use reinforcing elements (400x400x300 mm) when installing turnstile housing on a less steady foundation.

Passage zone modeling

When the turnstile is operated from ACS, it is recommended to place card readers in the turnstile housing or on the railings that form the passage zone. BH01 0-03 bracket is used for mounting readers on the BH02 series railings.

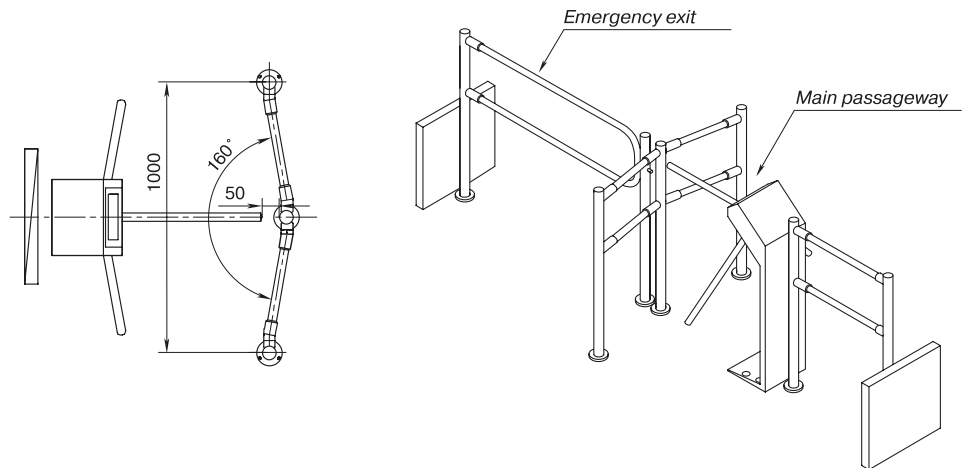

Turnstile top view

Example of an entrance zone project

Warranty

The warranty period is 5 (five) years commencing from the date of sale, unless otherwise determined in the delivery contract of the Product. In case of sale and installation of the equipment by authorized PERCo dealers and service centers, the warranty starts from the date of commissioning.

Should there be no date of sale on the warranty card, the warranty period shall commence from the date of manufacture specified in the Certificate and on the Product label.

TTR-04.1 Tripod Turnstile for indoor application



+50
+1
temperature range

12V
operating voltage

mechanical unlocking

2
passage direction

30
persons/min

Application

TTR-04.1 tripod turnstile is a normally closed electromechanical turnstile designed for indoor application.

The delivery set includes an RC-panel; the orientation of the RC-panel buttons relative to the directions of passage is set when connecting to the turnstile. It is recommended to install one turnstile per 500 people working the same shift based on a maximum working load of 30 persons/min. Turnstiles can be equipped with railings.



RC-panel

Operating modes

The turnstile provides passage control in two directions; the turnstile operating mode may be set independently for each passage direction. Supported operating modes:

- passage denial in both directions
- single passage in one direction and passage denial in the other direction
- single passage in both directions
- free passage in one direction and passage denial in the other direction
- free passage in one direction and single passage in the other direction
- free passage in both directions

When the power is turned off, both passage directions remain as before the power loss.

Main features

- operation of the turnstile from RC-panel, WRC, ACS
- built-in electronic board
- safe voltage – max. 14 V
- and low power consumption – max. 8.5 W
- automatic reset of the barrier arms to the home position after each passage
- damping device provides smooth silent operation



TTR-04.1 Tripod Turnstile for indoor application

- barrier arm rotation optical sensors record correctly the fact of passage
- built-in indication of operating modes
- integrated mechanical release lock
- possibility to connect an intrusion detector and a siren to the turnstile
- two control modes – pulse and potential
- galvanically isolated outputs
- Fire Alarm control input that allows connecting the emergency unlocking device
- relay outputs for connecting additional external indicators of the passage grant / denial



Pictogram indication block



Mechanical unlocking with a key

Design

Housing – powder coated steel. Barrier arms – stainless steel.

Housing finish options:



light beige with pearl mica effect



dark grey with pearl mica effect



glitter black

Item	Housing finish
TTR-04.1R	Sandpaper powder coating with pearl mica effect; light beige colour
TTR-04.1G	Sandpaper powder coating with pearl mica effect; dark grey colour
TTR-04.1E	Powder coating with lacquered finish; glitter black colour

Powder coating to RAL colours is available on order. The turnstile can be equipped with two types of barrier arms.

Item	Description
AS-04	Standard barrier arms
AA-04	Mechanical anti-panic barrier arms

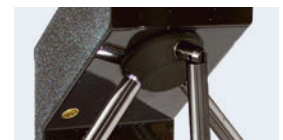

Mechanical anti-panic barrier arms

Operating conditions

The turnstile, with regard to resistance to environmental exposure, complies with GOST 15150-69 category NF4 (operation in premises with climate control).

Operation of the turnstile is allowed at ambient temperature from +1 °C to +50 °C and relative air humidity up to 80% at + 25 °C (non-condensing).

It is a serially produced product certified for compliance with applicable Russian and European CE standards.



Delivery set

Turnstile housing with built-in electronic board	1
Barrier arm (type to be chosen when ordering)	3
Key to mechanical unlocking	2
RC-panel (cable length of 6.6 m)	1
Mounting kit	1
Documentation set	1
Optional equipment (upon request)	
WRC (consisting of a receiver and two transmitters in the form of key fobs) with a range of up to 40 m	1
Intrusion detector (installed upon request at the manufacturing site)	1
Siren (for signalling that an unauthorized passage has been attempted)	1
PFG IR 10-15 anchor (SORMAT company, Finland)	4
Turnstile power supply	1

Technical specifications

Operating voltage	12±1.2 V DC				
Current consumption	max. 700 mA				
Power consumption	max. 8.5 W				
Overall dimensions with installed barrier arms (LxWxH)	855x810x1050 mm				
Passageway width	600 mm				
Turnstile weight	max. 30 kg				
Package dimensions	114x32x32 cm				
Throughput rate	<table border="0" style="width: 100%;"> <tr> <td style="width: 50%; text-align: center;">in the single passage mode</td> <td>30 persons / min</td> </tr> <tr> <td style="width: 50%; text-align: center;">in the free passage mode</td> <td>60 persons / min</td> </tr> </table>	in the single passage mode	30 persons / min	in the free passage mode	60 persons / min
in the single passage mode	30 persons / min				
in the free passage mode	60 persons / min				
Mean time to failure	4,000,000 passages				

Connection

TTR-04.1 is equipped with integrated CLB electronic board. All connections are made to the board contacts. The microcontroller installed on the board controls the turnstile's actuating mechanism, processes signals from optical sensors for moving the barrier arms, processes commands received from external devices, and generates signals about passages through the turnstile.

T5, TTD-03.1, TTD-03.2 also feature given electronic board thus this section content is applicable to the abovementioned turnstiles.

Built-in electronic board contacts description by connectors			
Connector	Contact	Electrical circuit	Designation
XT1.L	1, 2	Fire Alarm, GND	Emergency unlocking input
	3	GND	Power supply negative terminal
	4, 5, 6	Unlock A, Stop, Unlock B	Turnstile control inputs
	7, 8, 9	Led A, Led Stop, Led B	RC-panel indication outputs
XT1.H	1	GND	Power supply negative terminal
	2	+12 V	"Siren" device power supply positive terminal
	3, 4	Alarm 1, Alarm 2	Alarm relay contacts
	5	Common	Common contact for PASS A, PASS B, Ready, Det Out signals
	6	PASS A	PASS A relay contact (passage in the direction A)
	7	PASS B	PASS B relay contact (passage in the direction B)
	8	Ready	Ready relay contact
9	Det Out	Det Out relay contact	
XT2	1, 2, 3	+12 V, Detector, GND	Intrusion detector connection



TTR-04.1 Tripod Turnstile for indoor application

Built-in electronic board contacts description by connectors

Connector	Contact	Electrical circuit	Designation
XT3	1, 2	+12 V, GND	External power supply connection
XT4	1, 2, 3	NO, C, NC	Light A relay contacts – connection of a remote indicator for direction A (not included in the standard delivery set)
XT5	1, 2, 3	NO, C, NC	Light B relay contacts – connection of the remote indicator for direction B (not included in the standard delivery set)

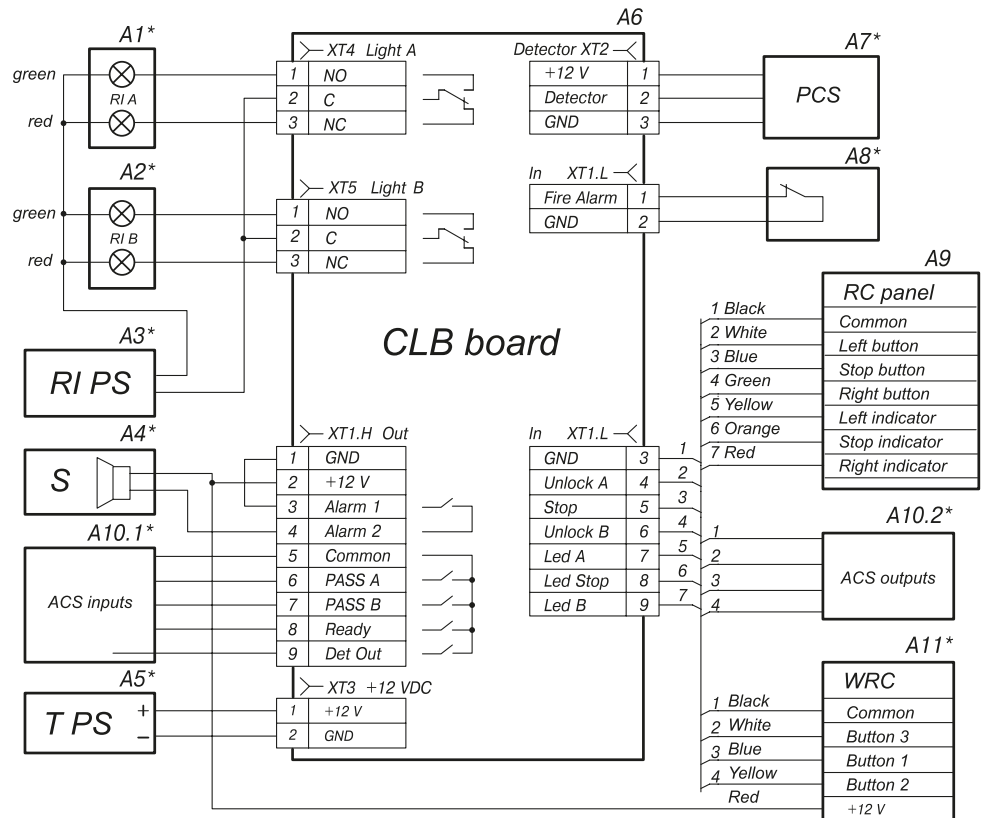

Wiring diagram of external connections to the CLB Board

Diagram description	
Item	Description
A1*, A2*	Remote indicators
A3*	Power supply for remote indicators
A4*	12V DC siren
A5*	Turnstile power supply
A6	CLB board
A7*	Intrusion detector
A8*	Device that gives an emergency unlocking command
A9	RC-panel
A10*	Access control system
A11*	WRC

* The equipment is not included in the standard delivery set



Operation algorithm

The turnstile can operate from the RC-panel (included in the delivery set), WRC or ACS controller.

Operation is performed by applying a low-level signal to Unlock A, Stop and Unlock B contacts relative to the GND contact. The response to these signals depends on the control mode selected by the J1 jumper wire.

Pulse control mode is when a pulse is applied to the Unlock A (B) input, the turnstile will automatically open for a single passage in the selected direction. The waiting time for the passage being completed does not depend on the duration of the control pulse and lasts 5 seconds. Sending a pulse to the Stop input locks both passage directions. Simultaneous sending of pulses to Unlock A (B) and Stop inputs places the turnstile in the "Free passage" mode in the selected direction.

Pulse mode is recommended when operating from the RC-panel. The orientation of RC-panel buttons (if the turnstile is facing the operator not with the front side, but with the rear side) can be changed by swapping the wires from the RC-panel that are connected to the Unlock A and Unlock B, as well as Led A and Led B, respectively.

Potential control mode is when the control signal is applied to the Unlock A (B) input, the turnstile remains unlocked in the selected direction during the entire holding signal time; Sending control signal to the Stop input locks both passage directions regardless of the signals at the Unlock A (B) inputs.

Potential mode is recommended during operation from the ACS controller.

Regardless of the selected control mode, PASS A or PASS B signals are generated when moving the barrier arms in one direction or the other. These signals can inform the ACS controller of the fact of passage.

Emergency passage opening is performed by removing a low-level signal from the Fire Alarm contact relative to the GND contact.

Note:

When operating the turnstile from the ACS controller, it is recommended to connect the RC-panel to the ACS controller.

Recommended cable type: CQR CABS8 8x0.22c.

The maximum allowed cable length from the power supply depends on its cross section and must be:

- 0.2 mm² cable cross-section – 10 m
- 0.75 mm² cable cross-section – 25 m
- 1.5 mm² cable cross-section – 50 m

Recommended cable type: power cable (2x0.75)



TTR-04.1 Tripod Turnstile for indoor application

Example of connection to the ACS

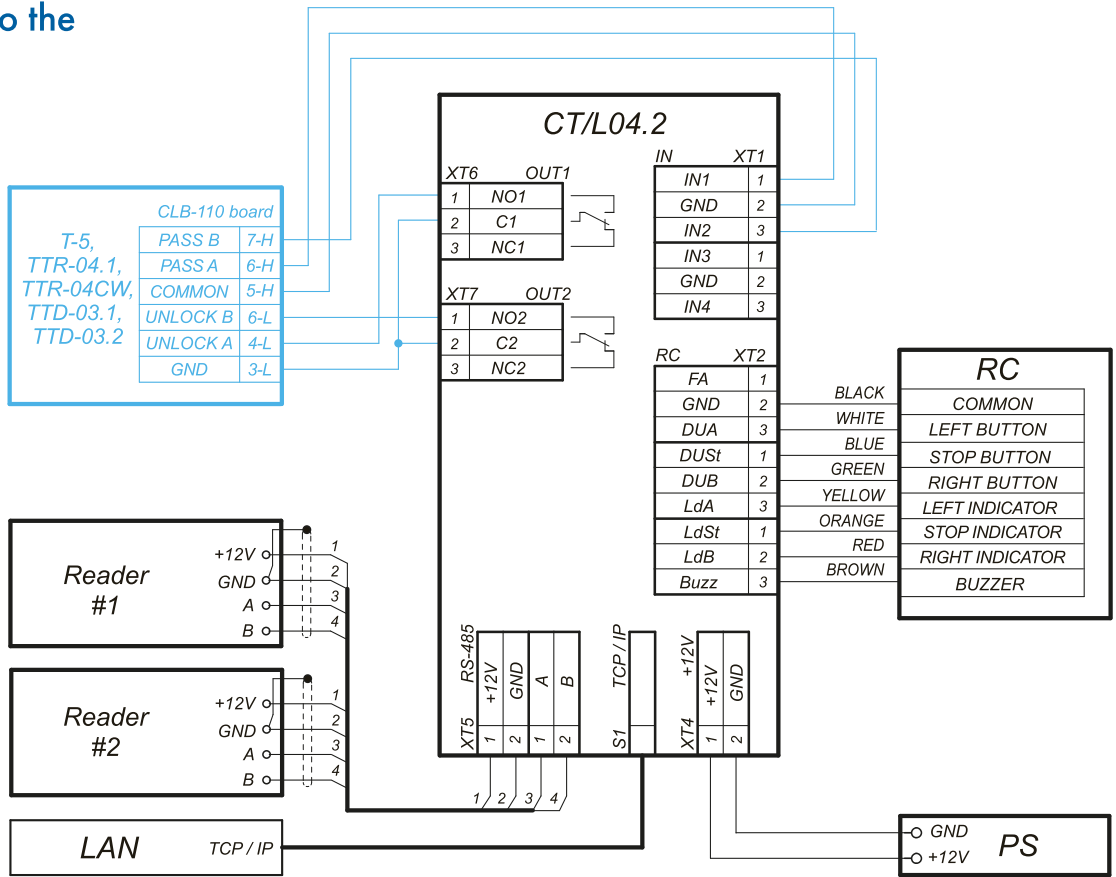

1 - jump wire when there is no Fire Alarm device

Example of turnstile connection to the ACS controller

Overall dimensions

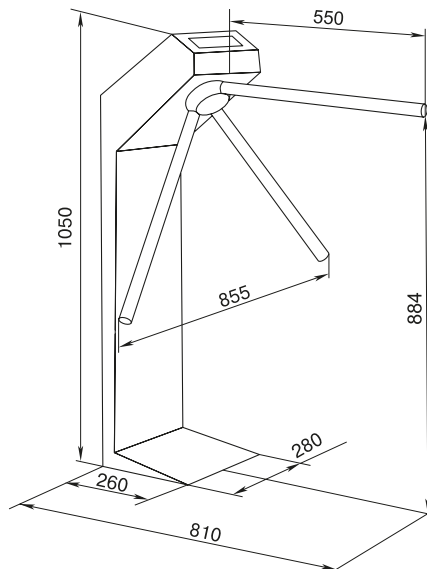

Overall dimensions



Mounting

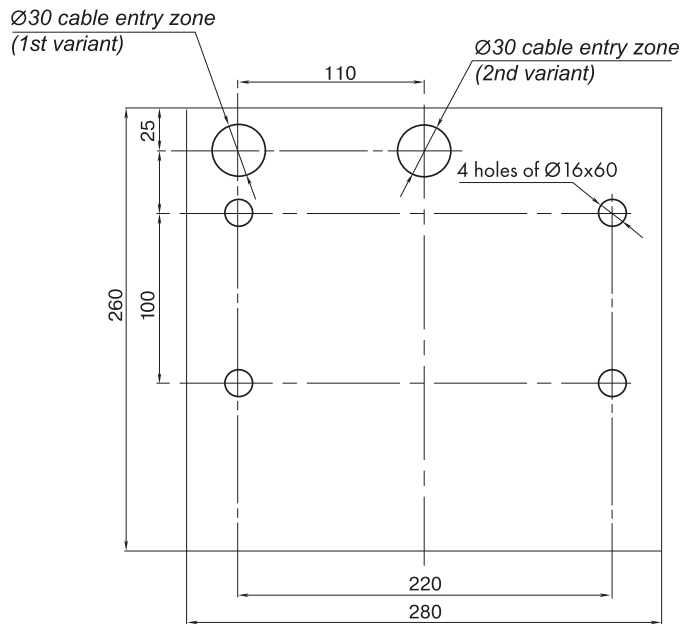

Hole marking for housing mounting and cable entry zone

Foundation requirements: concrete (not lower than 400 grade), stone, etc. foundation of at least 150 mm thick, use reinforcing elements (300x300x300 mm) when installing turnstile housing on a less steady foundation.

Passage zone modeling

When the turnstile is operated from ACS, it is recommended to place card readers in the turnstile housing or on the railings that form the passage zone. BH01 0-03 bracket is used for mounting readers on the BH02 series railings.

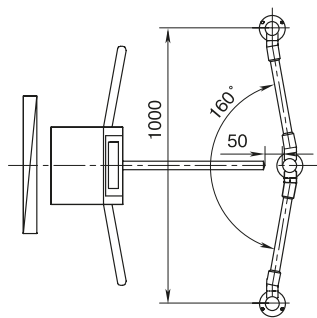

Turnstile top view

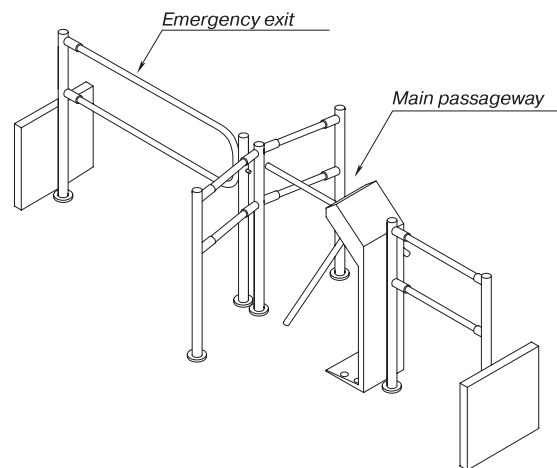

Example of an entrance zone project

Warranty

The warranty period is 5 (five) years commencing from the date of sale, unless otherwise determined in the delivery contract of the Product. In case of sale and installation of the equipment by authorized PERCo dealers and service centers, the warranty starts from the date of commissioning.

Should there be no date of sale on the warranty card, the warranty period shall commence from the date of manufacture specified in the Certificate and on the Product label.



TTR-04CW Tripod Turnstile for outdoor application



+50
-40
temperature range

12V
operating voltage

mechanical unlocking

2
passage direction

30
persons/min

Turnstiles, gates and railings

Application

TTR-04CW tripod turnstile is a normally closed electromechanical turnstile designed for outdoor operation under a canopy.

The turnstile housing features anti-corrosion coating, heating system and heat insulation which allows operating the turnstile at up to -40°C.

The delivery set includes an RC-panel; the orientation of the RC-panel buttons relative to the directions of passage is set when connecting to the turnstile. It is recommended to install one turnstile per 500 people working the same shift based on a maximum working load of 30 persons/min. Turnstiles can be equipped with railings.



RC-panel

Operating modes

The turnstile provides passage control in two directions, turnstile operating mode may be set independently for each passage direction. Supported operating modes:

- passage denial in both directions
- single passage in one direction and passage denial in the other direction
- single passage in both directions
- free passage in one direction and passage denial in the other direction
- free passage in one direction and single passage in the other direction
- free passage in both directions

When the power is turned off, both passage directions remain as before the power loss.

Main features

- operation of the speed gate from RC-panel, WRC, ACS
- built into the turnstile housing electronic board
- anti-corrosion coating of the turnstile housing
- heating system of the turnstile housing
- heat insulation of the housing

Turnstiles, gates and railings



- turnstile powered by 12 V DC external power supply
- turnstile heating system powered by 24 V AC external power supply
- automatic reset of the barrier arms to the home position after each passage
- damping device provides smooth silent operation
- barrier arm rotation optical sensors record correctly the fact of passage
- built-in indication of operating modes
- integrated mechanical release lock
- two control modes – pulse and potential
- galvanically isolated outputs
- Fire Alarm control input that allows connecting the emergency unlocking device
- relay outputs for connecting additional remote indicators of the passage grant / denial



Pictogram indication block



Mechanical unlocking with a key

Design

Housing – galvanized and powder-coated steel.



Light beige with pearl mica effect

Powder coating to RAL colours is available on order.

Operating conditions

TTR-04CW, with regard to resistance to environmental exposure, complies with GOST 15150 category N2 (operation outdoors under a canopy or in premises without climate control). The operation of the turnstile is allowed at ambient temperature from -40°C to +50°C and relative air humidity of up to 98% at + 25°C.

It is recommended to install one turnstile per 500 people working the same shift based on a maximum working load of 30 persons/min.

It is a serially produced product certified for compliance with applicable Russian and European CE standards.

Delivery set

Turnstile housing with built-in electronic board and heating system	1
Barrier arm	3
RC-panel (6.6 m-long cable)	1
Key to mechanical release lock	2
Mounting kit	1
Documentation set	1
Optional equipment (upon request)	
WRC (consisting of a receiver and two transmitters in the form of key fobs) with a range of up to 40 m	1
PFG IR 10-15 anchor (SORMAT company, Finland)	4
Turnstile power supply (12V, 2A)	1
Siren*	1

* The equipment is not included in the standard delivery set



TTR-04CW Tripod Turnstile for outdoor application

Technical specifications

Operating voltage	12±1.2 V DC	
Turnstile power consumption (excluding heating system)	max. 8.5 W	
Heating system operating voltage	24 V AC	
Heating system power consumption	max. 60 W	
Overall housing dimensions with installed barrier arms (LxWxH)	855x810x1050 mm	
Housing weight	max. 37 kg	
Passageway width	600 mm	
Package dimensions	114x32x32 cm	
Throughput rate	in the single passage mode	30 persons / min
	in the free passage mode	60 persons / min
Mean time to failure	4,000,000 passages	

Connection

TTR-04CW turnstile is equipped with integrated CLB electronic board. All connections are made to the board contacts. The microcontroller installed on the board controls the turnstile's actuating mechanism, processes signals from optical sensors for moving the barrier arms, processes commands received from external devices, and generates signals about passages through the turnstile.

Built-in electronic board contacts description by connectors

Connector	Contact	Electrical circuit	Designation
XT1.L	1, 2	Fire Alarm, GND	Emergency unlocking input
	3	GND	Power supply negative terminal
	4, 5, 6	Unlock A, Stop, Unlock B	Turnstile control inputs
	7, 8, 9	Led A, Led Stop, Led B	RC-panel indication outputs
XT1.H	1	GND	Power supply negative terminal
	2	+12 V	"Siren" device power supply positive terminal
	3, 4	Alarm 1, Alarm 2	Alarm relay contacts
	5	Common	Common contact for PASS A, PASS B, Ready, Det Out signals
	6	PASS A	PASS A relay contact (passage in the direction A)
	7	PASS B	PASS B relay contact (passage in the direction B)
	8	Ready	Ready relay contact
9	Det Out	Det Out relay contact	
XT2	1, 2, 3	+12 V, Detector, GND	Intrusion detector connection
XT3	1, 2	+12 V, GND	External power supply connection
XT4	1, 2, 3	NO, C, NC	Light A relay contacts – connection of a remote indicator for direction A (not included in the standard delivery set)
XT5	1, 2, 3	NO, C, NC	Light B relay contacts – connection of the remote indicator for direction B (not included in the standard delivery set)

Heating system controller board contacts description by connectors

Connector	Contact	Electrical circuit	Designation
XT1	1, 2	~24 V	Power supply connection
XT2	1, 2	Heater 1, Heater 2	Heating unit connection
XP1	1	"IND"	Heating system indicator connection

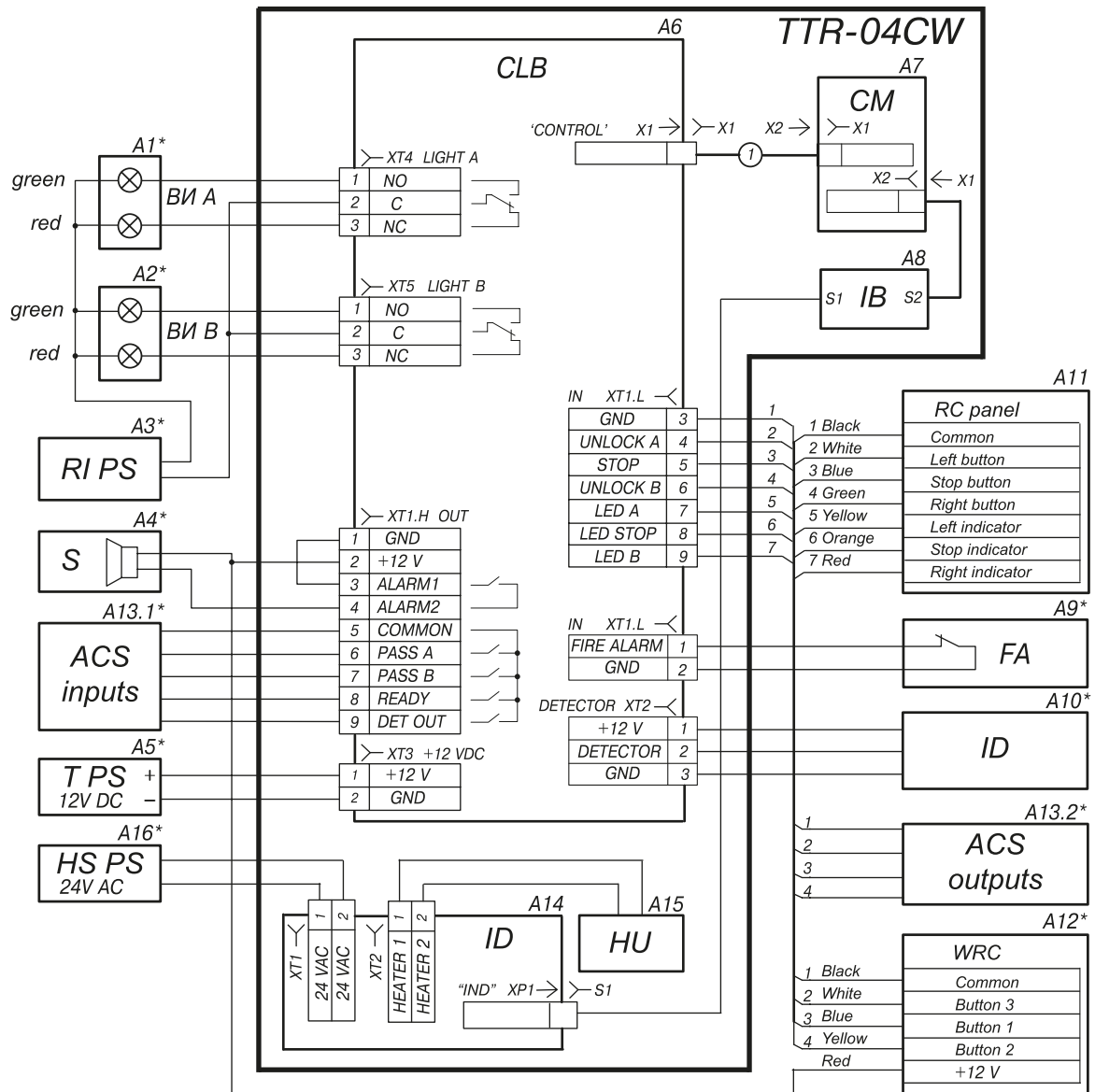

Wiring diagram of external connections to the CLB Board

Diagram description	
Item	Description
A1*, A2*	Remote indicators
A3*	Power supply for remote indicators
A4*	Siren
A5*	Turnstile power supply
A6	CLB board
A7	Turnstile control mechanism
A8	Indication board (on the turnstile top cover)
A9*	Device that gives an emergency unlocking command
A10*	Intrusion detector
A11*	RC-panel
A12	WRC
A13*	Access control system
A14	Heating system controller
A15	Heating unit
A16*	Heating system power supply

* The equipment is not included in the standard delivery set



TTR-04CW Tripod Turnstile for outdoor application

Operation algorithm

The turnstile can operate from the RC-panel (included in the delivery set), WRC or ACS controller.

Operation is performed by applying a low-level signal to Unlock A, Stop and Unlock B contacts relative to the GND contact. The response to these signals depends on the control mode selected by the J1 jumper wire.

Pulse control mode is when a pulse is applied to the Unlock A (B) input, the turnstile will automatically open for a single passage in the selected direction. The waiting time for the passage being completed does not depend on the duration of the control pulse and lasts 5 seconds. Sending a pulse to the Stop input locks both passage directions. Simultaneous sending of pulses to Unlock A (B) and Stop inputs places the turnstile in the "Free passage" mode in the selected direction.

Pulse mode is recommended when operating from the RC-panel. The orientation of RC-panel buttons (if the turnstile is facing the operator not with the front side, but with the back side) can be changed by swapping the wires from the RC-panel that are connected to the Unlock A and Unlock B, as well as Led A and Led B, respectively.

Potential control mode is when the control signal is applied to the Unlock A (B) input, the turnstile remains unlocked in the selected direction during the entire holding signal time. Sending control signal to the Stop input locks both passage directions regardless of the signals at the Unlock A (B) inputs.

Potential mode is recommended during operation from the ACS controller.

Regardless of the selected control mode, PASS A or PASS B signals are generated when moving the barrier arms in one direction or the other. These signals can inform the ACS controller of the fact of passage.

Emergency passage opening is performed by removing a low-level signal from the Fire Alarm contact relative to the GND contact.

Note:

When operating the turnstile from the ACS controller, it is recommended to connect the RC-panel to the ACS controller.

The maximum allowed cable length of the RC-panel (ACS controller) is 40 meters.
Recommended cable type: CQR CABS8 8x0.22c.

The maximum allowed cable length of the power supply depends on its cross section and must be:

- 0.2 mm² cable cross-section – 10 m
- 0.75 mm² cable cross-section – 25 m
- 1.5 mm² cable cross-section – 50 m

Recommended cable type: Power cable (2x0.75)



Example of connection to the ACS

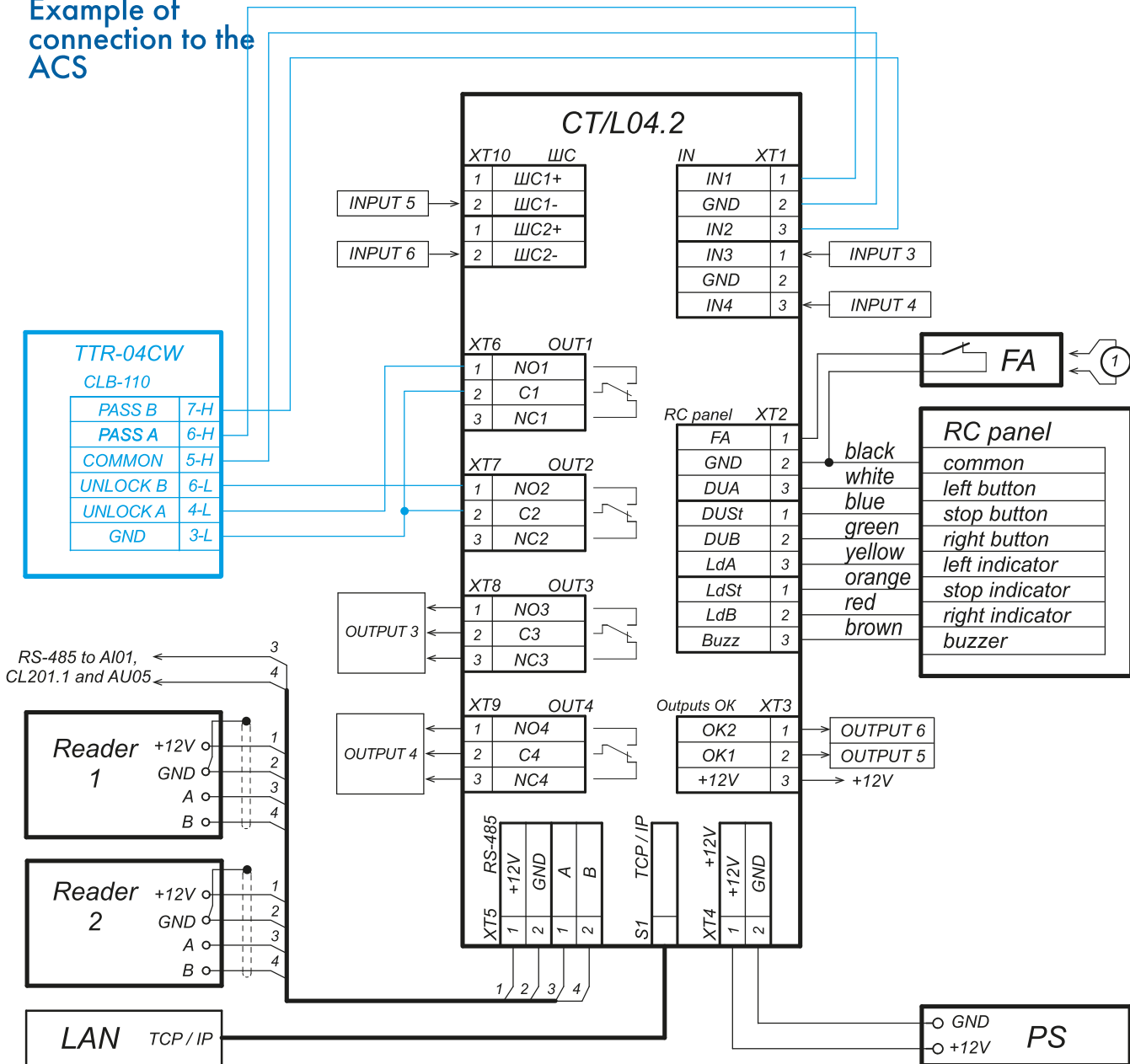

1 - jump wire when there is no Fire Alarm device

Example of turnstile connection to the ACS controller



TTR-04CW Tripod Turnstile for outdoor application

Overall dimensions

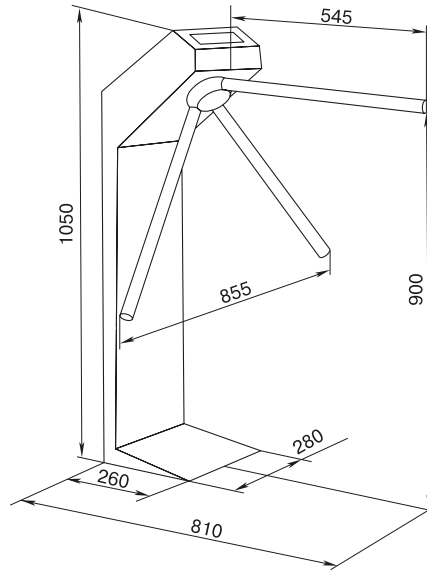

Overall dimensions

Mounting

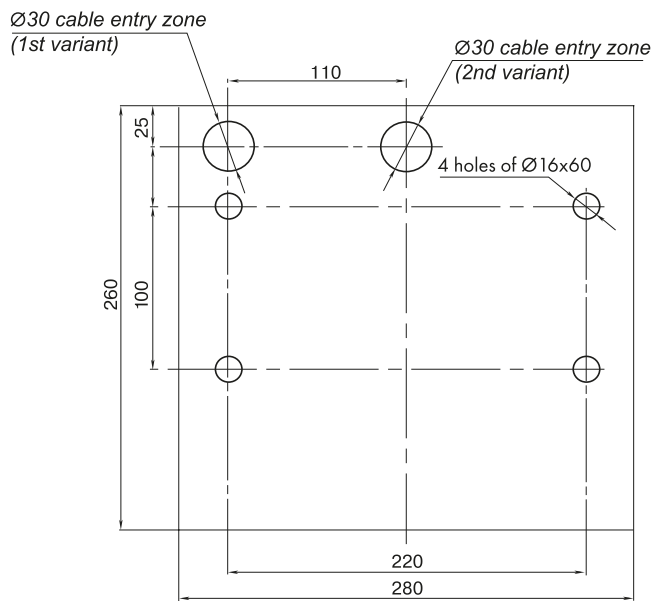

Hole marking for housing mounting and cable entry zone

When the turnstile is operated from ACS, it is recommended to place card readers in the turnstile housing or on the railings that form the passage zone. BH01 0-03 bracket is used for mounting readers on the BH02 series railings.



Passage zone modeling

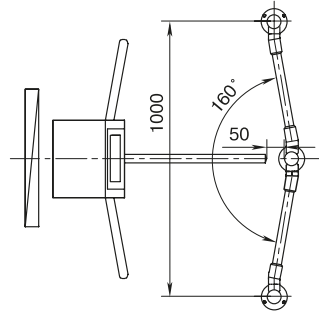

Turnstile top view

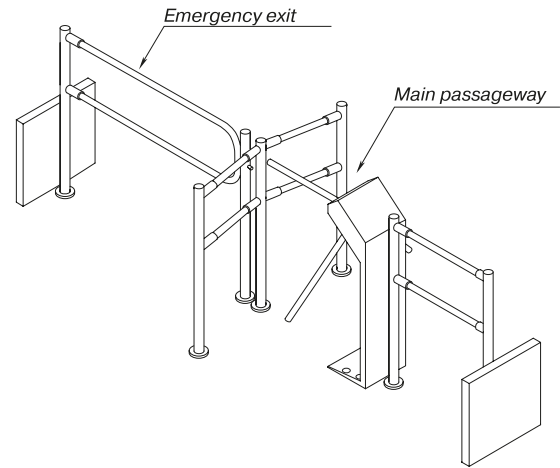

Example of an entrance zone project

Warranty

The warranty period is 5 (five) years commencing from the date of sale, unless otherwise determined in the delivery contract of the Product. In case of sale and installation of the equipment by authorized PERCo dealers and service centers, the warranty starts from the date of commissioning.

Should there be no date of sale on the warranty card, the warranty period shall commence from the date of manufacture specified in the Certificate and on the Product label.



T-5 Tripod turnstile



+50
+1
temperature range

12V
operating voltage

mechanical unlocking

2
passage direction

30
persons/min

Turnstiles, gates and railings

Application

T-5 tripod turnstile is a normally closed electromechanical turnstile designed for indoor operation. The delivery set includes an RC-panel. Buttons' orientation relative to the passage directions is to be set upon connecting the RC-panel to the turnstile. It is recommended to install one turnstile per 500 people working the same shift based on a maximum working load of 30 persons/min. The turnstile can be equipped with railings.



RC-panel

Operating modes

The turnstile provides passage control in two directions, turnstile operating mode may be set independently for each passage direction. Supported operating modes:

- passage denial in both directions
- single passage in one direction and passage denial in the other direction
- single passage in both directions
- free passage in one direction and passage denial in the other direction
- free passage in one direction and single passage in the other direction
- free passage in both directions

When the power is turned off, both passage directions remain as before the power loss.

Main features

- operation of the turnstile from RC-panel, WRC, ACS
- built into the turnstile housing electronic board
- safe voltage – max. 14 V
- and low power consumption – max. 8.5 W
- automatic reset of the barrier arms to the home position after each passage
- damping device provides smooth silent operation
- barrier arm rotation optical sensors record correctly the fact of passage
- integrated mechanical release lock

Turnstiles, gates and railings

- possibility to connect an intrusion detector and a siren to the turnstile
- two control modes – pulse and potential
- galvanically isolated outputs
- Fire Alarm control input that allows connecting the emergency unlocking device



Pictogram indication



Mechanical unlocking with a key

Design

Housing – powder-coated steel. Colours – beige, light grey. The turnstile can be equipped with three types of barrier arms:

Item	Description
AS-05	Standard barrier arms (steel, powder coating, black)
AS-04	Standard barrier arms (inox.)
AA-04	Mechanical anti-panic barrier arms (inox.)

Operating conditions

The turnstile, with regard to resistance to environmental exposure, complies with GOST 15150-69 category NF4 (operation in premises with climate control). The operation of the turnstile is allowed at ambient temperature from +1 °C to +50 °C and relative air humidity up to 80% at + 25 °C (non-condensing).

It is a serially produced product certified for compliance with applicable Russian and European CE standards.

Delivery set

Turnstile housing	1
Barrier arm (model to be chosen when ordering)	3
RC-panel (cable length of 6.6 m)	1
Key to mechanical release lock	2
Mounting kit	1
Documentation set	1
Optional equipment (upon request)	
WRC (consisting of a receiver and two transmitters in the form of key fobs) with a range of up to 40 m	1
Intrusion detector (installed upon request at the manufacturing site)	1
Siren (alert on an unauthorized passage attempt)	1
PFG IR 10-15 anchor (SORMAT company, Finland)	4
Turnstile power supply	1

Technical specifications

Operating voltage	12±1.8 V DC	
Current consumption	max. 700 mA	
Power consumption	max. 8.5 W	
Overall dimensions with installed barrier arms (LxWxH)	with AS-05 barrier arms	744x 744x1025 mm
	with AS-04, AA-04 barrier arms	861x833x1025 mm
Passageway width	with AS-05 barrier arms	500 mm
	with AS-04, AA-04 barrier arms	600 mm



T-5 Tripod turnstile

Turnstile weight	35 kg	
Package dimensions (L×W×H)	114x32x32 cm	
Throughput rate	in the single passage mode	30 persons / min
	in the free passage mode	60 persons / min
Mean time to failure	4,000,000 passages	

Connection

T-5 turnstile is equipped with integrated CLB electronic board.
 The connection procedure is stated in the "TTR-04.1 Tripod turnstile" section.

Note

Turnstile does not provide connection of remote indicators (Light A, Light B relay contacts).

Overall dimensions

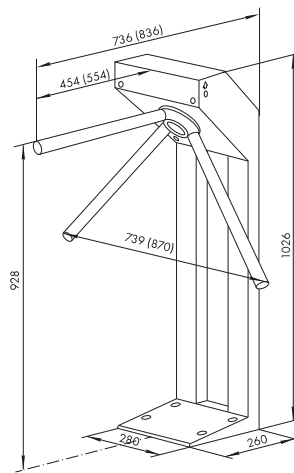

Overall dimensions

Mounting

Foundation requirements: concrete (grade 400 or higher), stone or similar foundations of at least 150 mm thick. For the installation on a less steady foundation it is recommended to apply reinforcing elements (300×300×300 mm).

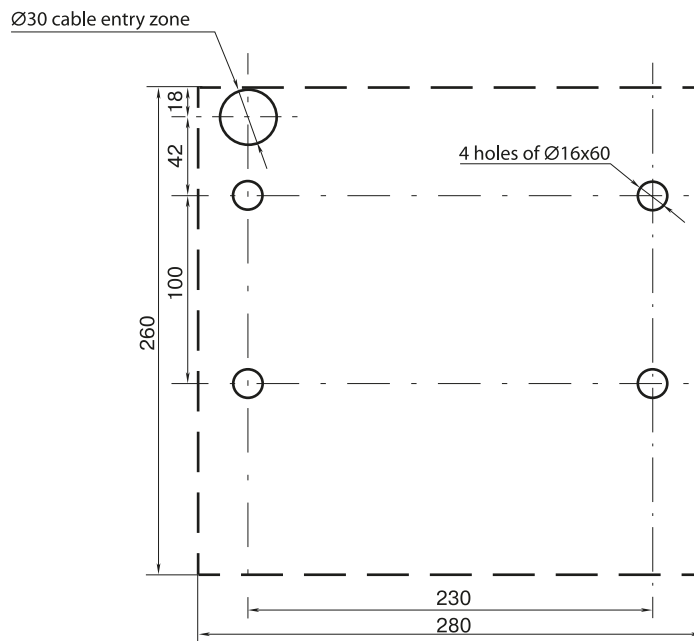

Hole marking for housing mounting and cable entry zone



Passage zone modeling

When the turnstile is operated from ACS, it is recommended to place card readers in the turnstile housing or on the railings that form the passage zone. BH01 0-03 bracket is used for mounting readers on the BH02 series railings.

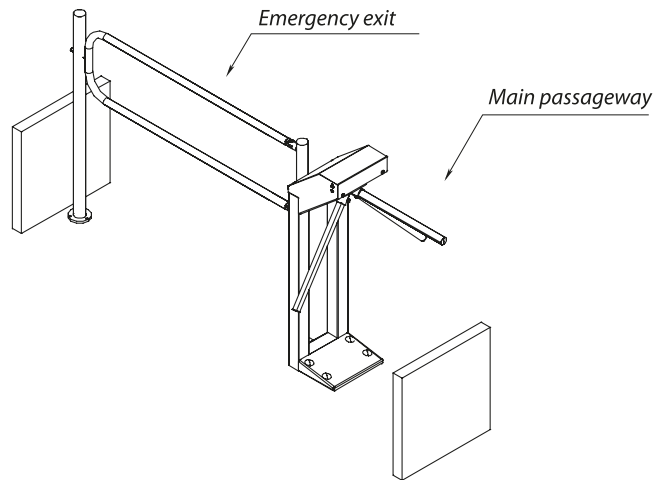

Example of an entrance zone project

Warranty

The warranty period is 5 (five) years commencing from the date of sale, unless otherwise determined in the delivery contract of the Product. In case of sale and installation of the equipment by authorized PERCo dealers and service centers, the warranty starts from the date of commissioning.

Should there be no date of sale on the warranty card, the warranty period shall commence from the date of manufacture specified in the Certificate and on the Product label.



TTD-10A Box tripod turnstile



temperature range



operating voltage



anti-panic barrier arms



passage direction



persons/min



Turnstile mode indication



Passage direction indication



Automatic anti-panic barrier arms

Application

TTD-10A box tripod turnstile is a normally closed electromechanical turnstile designed for both outdoor (standard version) and indoor operation.

Modularity is a specific feature of the TTD-08A turnstile which allows integrating into the turnstile a wide range of optional equipment: card capture reader, coin acceptor, proximity readers, biometric readers, barcode readers, etc. The turnstile is equipped with automatic anti-panic barrier arms that fold down at a signal from an emergency unlocking device or power loss and is made of high-quality stainless steel.

Three design versions are available and feature different side modules:

TTD-10AB (standard version) features two standard side modules,

TTD-10AC (with built-in card capture reader) features one standard side module and one side module with a built-in card capture reader,

TTD-10AP (with built-in coin acceptor) features one standard side module and one side module with a built-in coin acceptor.

TTD-12AB (standard motorized version) features two standard side modules.

TTD-12AC (motorized version with built-in card capture reader) features one standard side module and one side module with a built-in card capture reader.

The delivery set also includes two boxes with side covers for different application and are to be chosen when ordering the turnstile.

Type	Design	Application
C-10B	from stainless steel	without additional functions
C-10R	with window from radio-transparent material	to built-in RFID-reader installation
C-10A	with a bracket and a window from radio-transparent material	for face recognition terminal and RFID-reader installation
C-10Q	from stainless steel and tinted glass with transparent window	for built-in barcode reader installation
C-10F	with a bracket	for biometric reader installation
C-10C	with a slot for card capturing	to use as a part of turnstile with a card capture reader

The delivery set also includes an RC-panel; RC-panel buttons orientation relative to the passage directions is set when connecting to the turnstile.

It is recommended to install one turnstile per 500 people working the same shift based on a maximum working load of 30 persons/min.

Operating modes

The turnstile provides passage control in two directions, turnstile operating mode may be set independently for each passage direction. Supported operating modes:

- passage denial in both directions
- single passage in one direction and passage denial in the other direction
- single passage in both directions
- free passage in one direction and passage denial in the other direction
- free passage in one direction and single passage in the other direction
- free passage in both directions

When the power is turned off, the turnstile barrier arm falls down, and both directions become open for free passage.

Main features

- operation of the turnstile from RC-panel, WRC, ACS
- possibility of outdoor application
- built-in electronic board
- safe voltage – max. 14 V
- power consumption - max. 84 W (maximum value of 84 W – within 5 seconds after powering the turnstile or removing the Fire Alarm signal; the power consumption is max. 40 W during the rest of the operation)
- to power the turnstile, a power supply of min. 8 A is needed for 5 seconds
- when a command is given by the emergency unlocking device, as well as when the turnstile power supply is turned off, the passage is automatically opened by moving the barrier arm to the vertical position; after restoring the turnstile supply voltage or removing the Fire Alarm signal, the barrier arm is moved to the working position manually
- automatic reset of the barrier arms to the home position after each passage
- damping device provides smooth silent operation
- barrier arm rotation optical sensors record correctly the fact of passage
- possibility to install a wide range of optional equipment by using special side modules (with built-in card capture reader and coin acceptor for corresponding turnstile design versions) and special side covers to be installed into the turnstile: proximity readers, biometric readers, barcode readers etc.
- possibility to connect an intrusion detector and a siren to the turnstile
- two control modes – pulse and potential
- galvanically isolated outputs
- Fire Alarm control input that allows connecting the emergency unlocking device
- relay outputs for connecting additional external indicators of the passage grant / denial

Design

Turnstile housing, side modules, side covers and barrier arms – stainless steel.

Operating conditions

TTD-10A turnstile, with regard to resistance to environmental exposure, complies with GOST15150-69 category N1 (for outdoor application). The operation of the turnstile is allowed at ambient temperature from -20° C to +50° C (when used under a canopy - up to +55° C) and relative air humidity of up to 90% at +30° C.

RC-panel should be operated at ambient air temperature from +1° C to +40° C and relative air humidity of up to 80% at +25° C. When installing optional equipment, installers should take into consideration the operating conditions of installed equipment.

It is a serially produced product certified for compliance with applicable Russian and European CE standards.



TTD-10A Box tripod turnstile

Delivery set

Turnstile housing (box #1)			1
	TTD-10AB		2
Side modules (box #2):	TTD-10AC	Standard	1
		with a card capture reader	1
	TTD-10AP	Standard with a coin acceptor	1
Side cover (packages #3 and #4)			2
RC-panel			1
Mounting kit			1
Documentation set			1

Technical specifications

Operating voltage	12±1.2 VDC	
Current consumption	max. 7 A	
Power consumption	84 W	
Overall dimensions with installed barrier arms (LxWxH)	1361x750x1024 mm	
Passageway width	560 mm	
Turnstile weight	max. 100 kg	
Throughput in single passage mode	30 persons / min	
Throughput in free passage mode	60 persons / min	
IP Code	TTD-10AB	IP55 (EN 60529)
	TTD-10AC	IP41 (EN 60529)
	TTD-10AP	IP54 (EN 60529)
Mean time to failure	4,000,000 passages	
Mean lifetime	8 years	

Connection

TTD-10A turnstile is equipped with integrated CLB.140 electronic board. All connections are made to the board contacts through the XTU1 – XTU3 remote terminal blocks. The microcontroller installed on the board controls the turnstile's actuating mechanism, processes signals from optical sensors for moving the barrier arms, processes commands received from external devices, and generates signals about passages through the turnstile.

Built-in electronic board contacts description by connectors

Connector	Contact	Electrical circuit	Designation
XT1.L	1, 2, 3	+12 V, Detector, GND	ID connection input
	4-12	Internal	XTU2 remote terminal block connection (contacts 3-11)
XT1.H	1, 2	GND, +12 V	+12V output for powering siren or additional devices
	3, 4	Alarm 1, Alarm 2	Siren control
	5-7	Internal	XTU2 remote terminal block connection (contacts 12-14)
	8	Ready	Abnormal turnstile operation signal output
	9	Det Out	Intrusion detector output (transit)
XT3	1, 2	Internal	XTU1 remote terminal block connection (contacts 1-2)
XT4	1, 2, 3	NO, C, NC	Light A relay contacts – connection of the remote indicator for direction A (not included in the standard delivery set)
XT5	1, 2, 3	NO, C, NC	Light B relay contacts – connection of the remote indicator for direction B (not included in the standard delivery set)

Turnstiles, gates and railings



XTU1	1, 2	+12V, GND	12 VDC external power supply connection
	1, 2	+12V, GND	+12VDC for optional equipment
XTU2	3, 4	Fire Alarm, GND	Emergency passage opening control input
	5-8	GND, Unlock A, Stop, Unlock B	Turnstile control inputs
	9-11	Led A, Led Stop, Led B	RC-panel indication outputs
	12-14	Common PASS A, PASS B	Signals of the passage sensors for directions A and B
XTU3	1-5	+12V, R, GND, L, +7V	Connection of indication cable from the main cover indication block
	6, 8	+7V, GND	Connection of indication cable from the right side indication block
	7, 9	+7V, GND	Connection of indication cable from the left side indication block

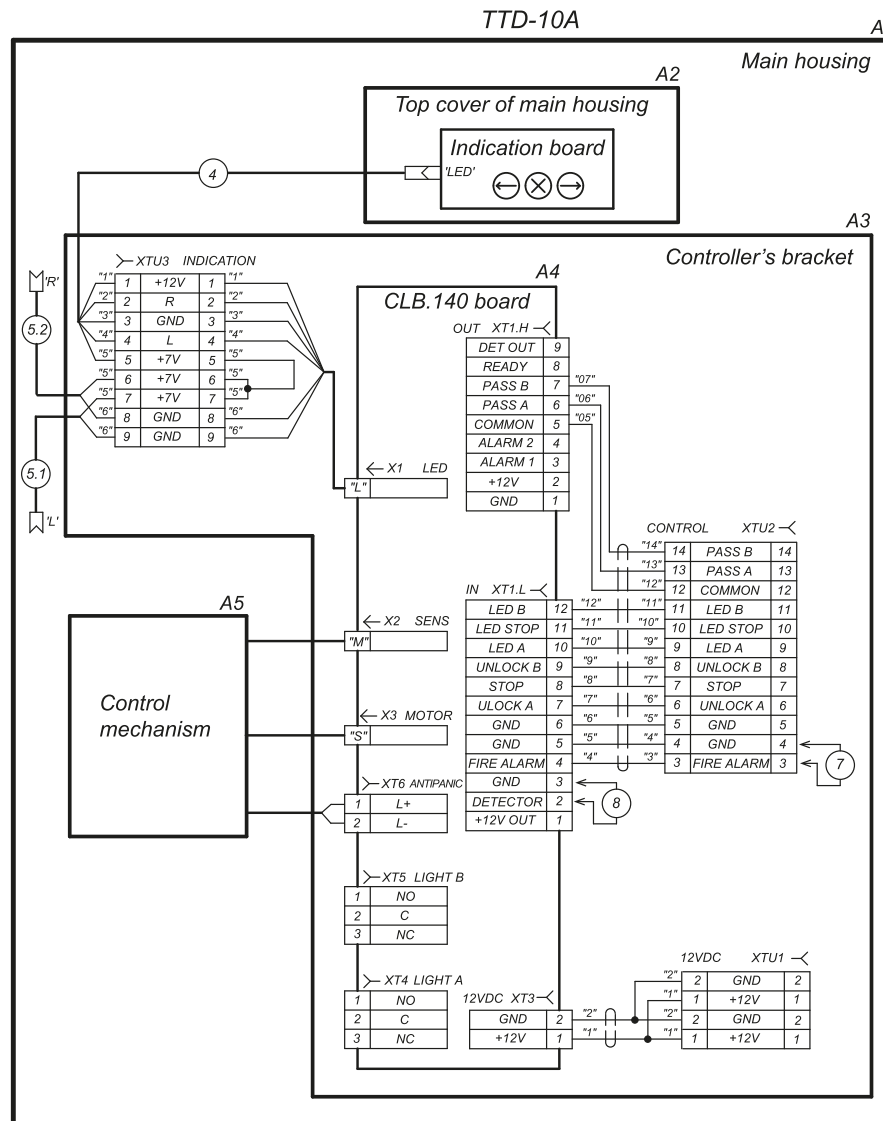

TTD-10 wiring diagram



TTD-10A Box tripod turnstile

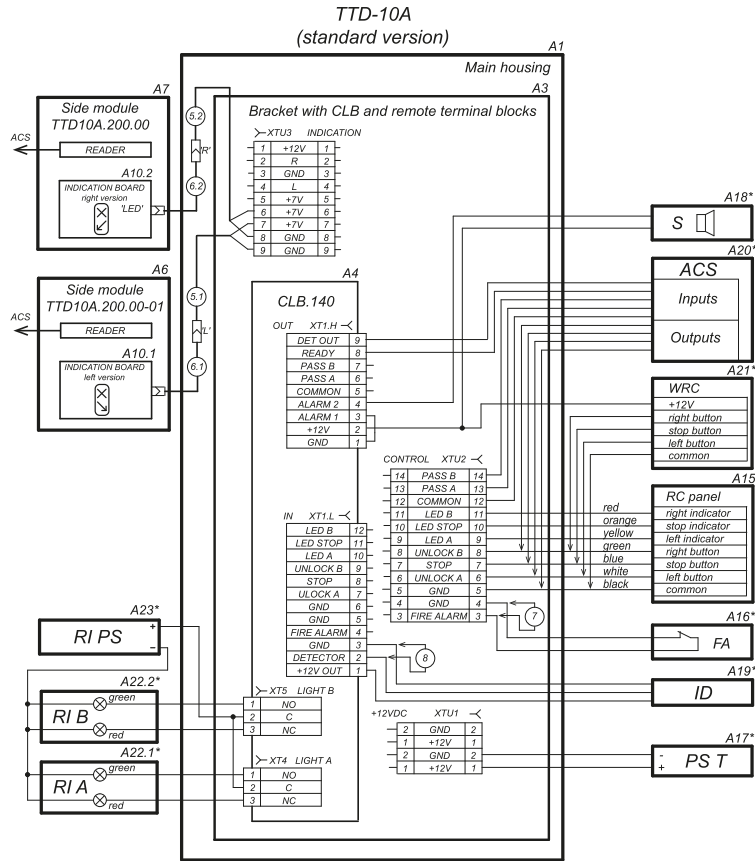

Connection layout of TTD-10AB and optional equipment

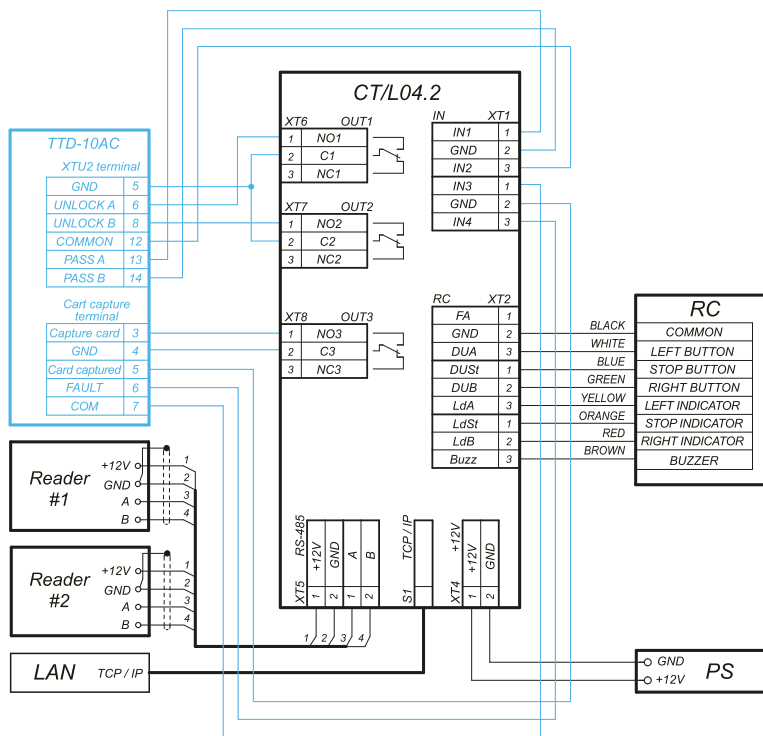

Wiring diagram of TTD-10AC and optional equipment

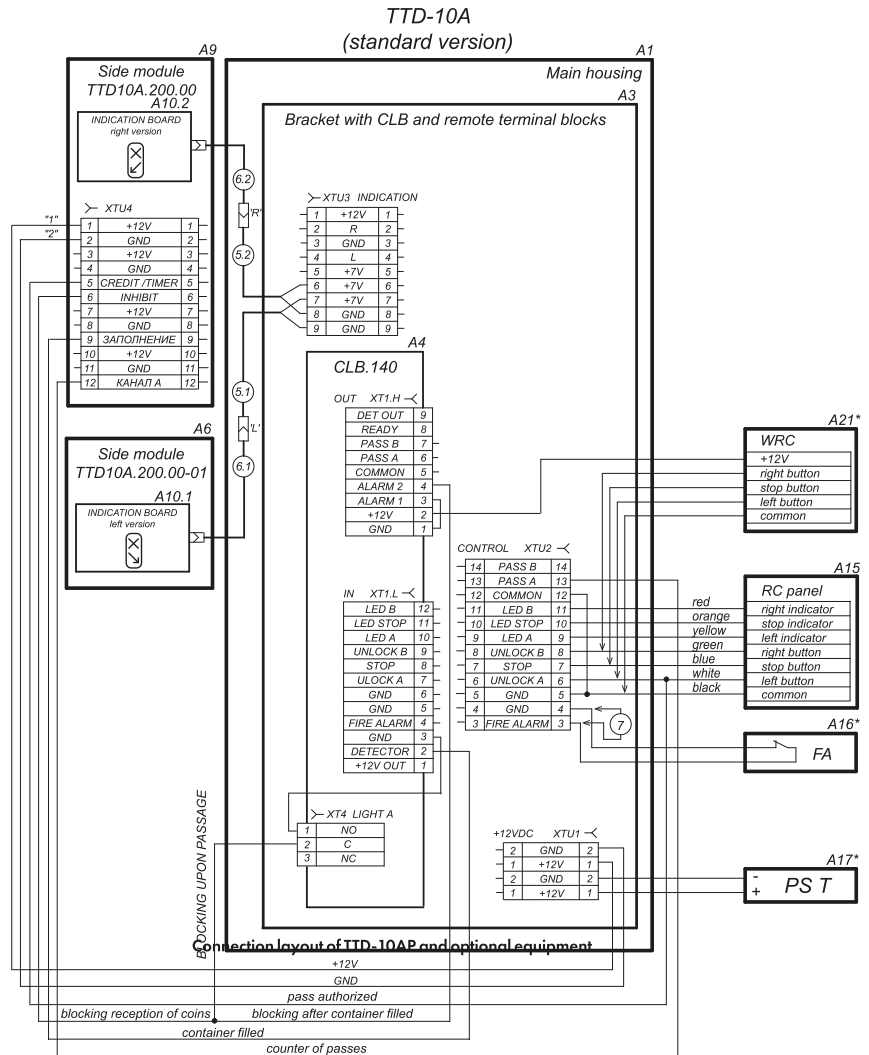

Wiring diagram of TTD-10AP and optional equipment

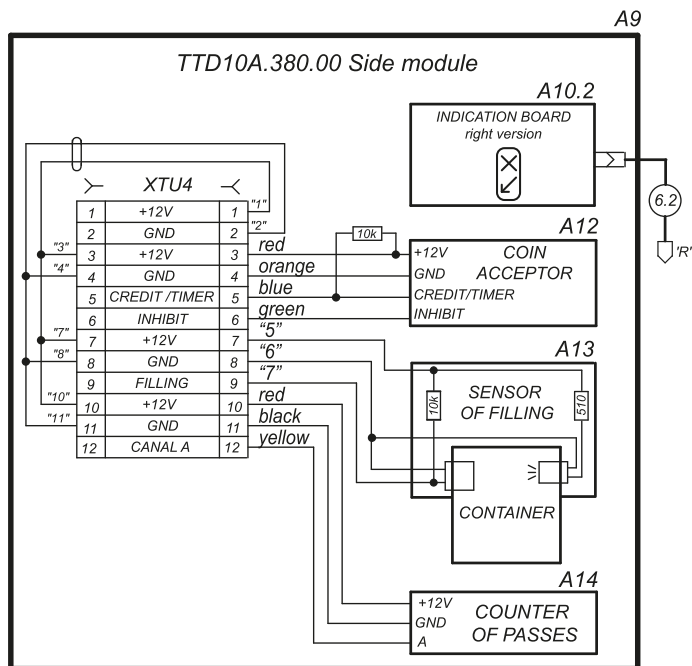

Wiring diagram of the TTD-10AP side module



TTD-10A Box tripod turnstile

Layout description	
Item	Description
A1	Main housing
A2	Cover assembly
A3	Bracket for controller
A4	Control board
A5	Control mechanism
A6	Left standard side module
A7	Right standard side module
A8	Side module with a card capture reader
A9	Side module with a coin acceptor
A10	Side module indication board
A11	Card capture reader mechanism
A12	ICT UCA2 coin acceptor
A13	Container filling sensor
A14	Yenox H2-7EA2 passage counter
A15	RC-panel
A16*	Emergency passage opening device (Fire Alarm)
A17*	12V DC /8A turnstile power supply
A18*	12V DC siren
A19*	Intrusion detector
A20*	ACS controller
A21*	WRC
A22*	Remote indicators
A23*	Remote indicators PS
XTU1 – XTU4	Remote terminal blocks
4	Cover indication cable
5	Indication cable from the main housing to side modules
6	Side modules indication cables
7	Jumper wire if there is no emergency passage opening device FA (A16)
8	Jumper wire if there is no intrusion detector (A19)

* The equipment is not included in the standard delivery set

Operation algorithm

The turnstile can operate from the RC-panel (included in the delivery set), WRC or ACS controller. Operation is performed by applying a low-level signal to Unlock A, Stop and Unlock B contacts relative to the GND contact. The response to these signals depends on the control mode selected by the J1 jumper wire.

Pulse control mode is when a pulse is applied to the Unlock A (B) input, the turnstile will automatically open for a single passage in the selected direction; the waiting time for the passage being completed does not depend on the duration of the control pulse and lasts 5 seconds. sending a pulse to the Stop input locks both passage directions; simultaneous sending of pulses to Unlock A (B) and Stop inputs places the turnstile in the "Free passage" mode in the selected direction.

It is recommended to use pulse mode during operation from RC-panel or WRC. The orientation of RC-panel buttons (if the turnstile is facing the operator not with the front side, but with the rear side) can be changed by swapping the wires from the RC-panel that are connected to the Unlock A and Unlock B, as well as Led A and Led B, respectively.

Potential control mode is when the control signal is applied to the Unlock A (B) input, the turnstile remains unlocked in the selected direction during the entire holding signal time; Sending control signal to the Stop input locks both passage directions regardless of the signals at the Unlock A (B) inputs.

Turnstiles, gates and railings



Potential mode is recommended during operation from the ACS controller.

Regardless of the selected control mode, PASS A or PASS B signals are generated when moving the barrier arms in one direction or the other. These signals can inform the ACS controller of the fact of passage.

Emergency passage opening is performed by removing a low-level signal from the Fire Alarm contact relative to the GND contact

Note:

When operating the turnstile from the ACS controller, it is recommended to connect the RC-panel to the ACS controller.

The maximum allowed cable length of the RC-panel (ACS controller) is 40 meters.

The maximum allowed cable length of the power supply depends on its cross section and must be:

- 1.5 mm² cable cross-section – 10 m
- 2.5 mm² cable cross-section – 15 m

Example of connection to the ACS

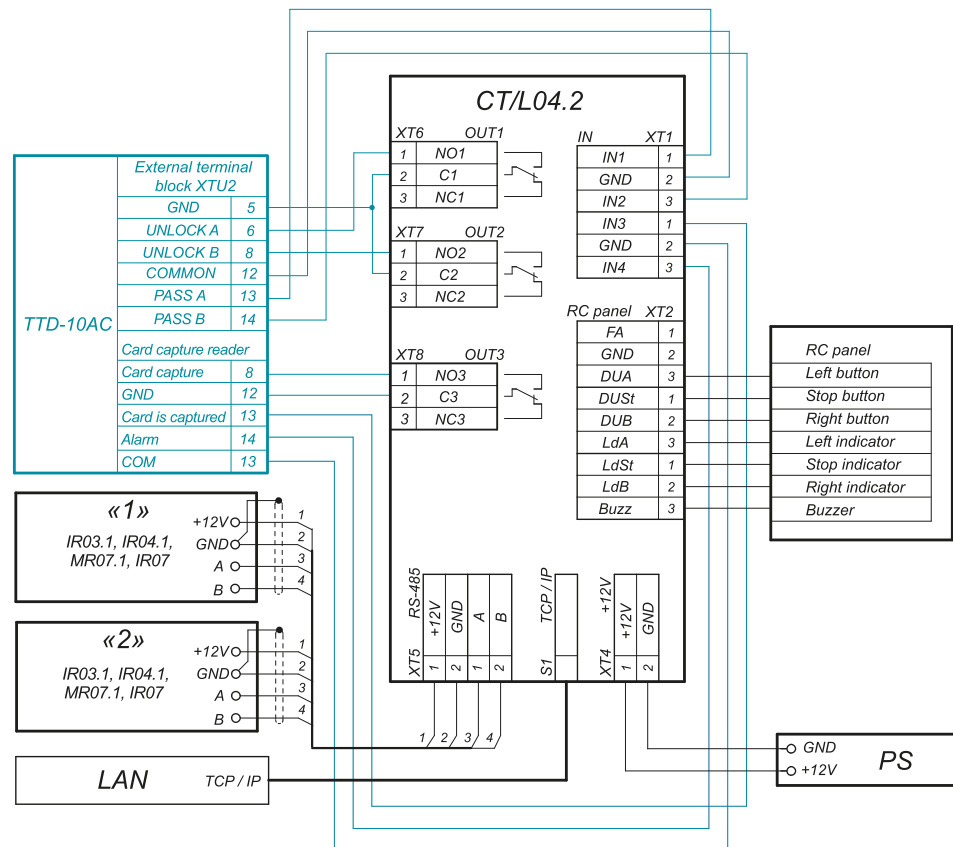

Example of connection of the TTD-10A turnstile to the ACS



TTD-10A Box tripod turnstile

Overall dimensions

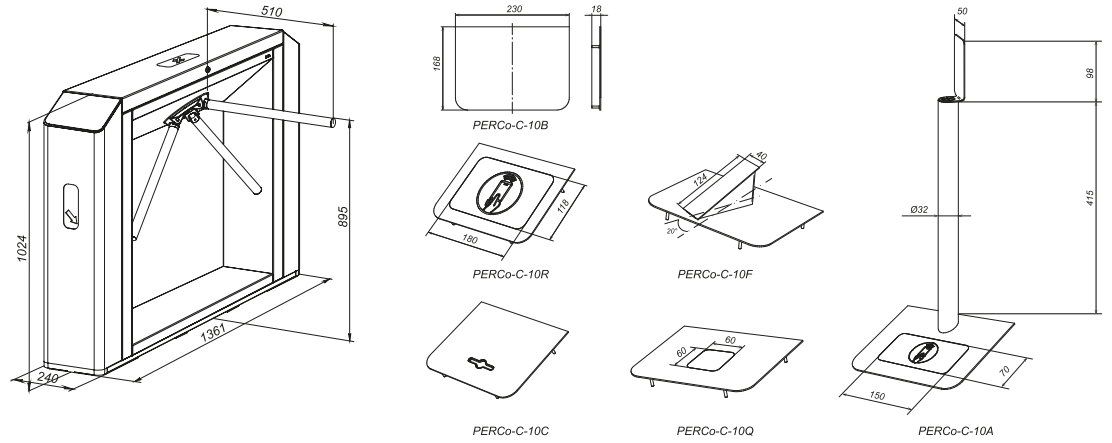

Built-in barcode scanner



Built-in proximity card reader



Built-in card capture reader



Built-in reader and coin acceptor



Built-in reader and a mounting arm for external equipment installation



Cover for external biometric reader installation

Overview and overall dimensions of different side covers.

Mounting

Foundation requirements: concrete (not lower than 400 grade), stone, etc. foundation of at least 150 mm thick, use reinforcing elements (400x400x300 mm) when installing turnstile housing on a less steady foundation.

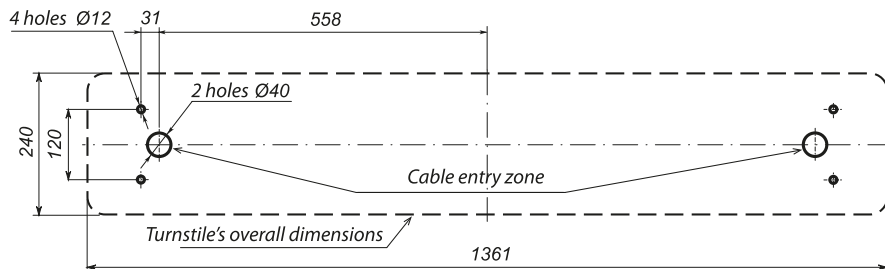

Hole marking for turnstile mounting and cable entry zone

Warranty

The warranty period is 5 (five) years commencing from the date of sale, unless otherwise determined in the delivery contract of the Product. In case of sale and installation of the equipment by authorized PERCo dealers and service centers, the warranty starts from the date of commissioning.

Should there be no date of sale on the warranty card, the warranty period shall commence from the date of manufacture specified in the Certificate and on the Product label.

TTD-08A Box tripod turnstile



+55
-20
temperature range

12V
operating voltage

anti-panic barrier arms

2
passage direction

30
persons/min

72W
power consumption

Application

TTD-08A box tripod turnstile made of stainless steel is a modern solution to arrange access control with a possibility of outdoor operation without a canopy. Due to its design, the turnstile can be installed at entrances of company offices, enterprises, business centers, banks etc.

TTD-08A key features

- modern housing design made of stainless steel
- pictogram indication which is well seen in any lighting
- places for hidden installation of readers inside the housing are indicated with pictograms
- automatic anti-panic barrier arms
- possibility to operate outdoors without a canopy at temperatures from -20° C to +45° C (under a canopy from -20°C to +55°C)



Operating modes indication



Passage direction indication

Operating modes

It is recommended to install one turnstile per 500 people working the same shift based on a maximum working load of 30 persons/min. Turnstiles can be equipped with railings.

The turnstile provides passage control in two directions, the turnstile operating mode may be set independently for each passage direction. Supported operating modes:

- passage denial in both directions
- single passage in one direction and passage denial in the other direction
- single passage in both directions
- free passage in one direction and passage denial in the other direction
- free passage in one direction and single passage in the other direction
- free passage in both directions

When the power is turned off, the turnstile barrier arm falls down, and both directions become open for free passage.



TTD-08A Box tripod turnstile

Main features

- operation of the turnstile from RC-panel, WRC, ACS
- possibility of outdoor application
- built-in electronic board
- safe voltage – max. 14 V
- power consumption - max. 72 W (maximum value of 72 W – within 5 seconds after powering the turnstile or removing the Fire Alarm signal; the power consumption is max. 30 W during the rest of the operation)
- to power the turnstile, a power supply of min. 6 A is needed for 5 seconds
- when a command is given by the emergency unlocking device, as well as when the turnstile power supply is turned off, the passage is automatically opened by moving the barrier arm to the vertical position
- after restoring the turnstile supply voltage or removing the Fire Alarm signal, the barrier arm is moved to the working position manually
- automatic reset of the barrier arms to the home position after each passage
- damping device provides smooth silent operation
- barrier arm rotation optical sensors record correctly the fact of passage
- turnstile features additional light indication of the passage direction on the side panels
- possibility to install built-in proximity readers
- reader interrogation zones are indicated with backlit pictograms
- possibility to connect an intrusion detector and a siren to the turnstile
- two control modes – pulse and potential
- outputs galvanic isolation
- Fire Alarm control input that allows connecting the emergency unlocking device
- relay outputs for connecting additional external indicators of the passage grant/denial

Design

Turnstile housing – stainless steel with ABS plastic inserts.
Barrier arms – stainless steel.

Operating conditions

TTD-08A turnstile, with regard to resistance to environmental exposure, complies with GOST 15150-69 category N1 (for outdoor application). The operation of the turnstile is allowed at ambient temperature from +20°C to +55°C and relative air humidity up to 80% at + 25°C. It is a serially produced product certified for compliance with applicable Russian and European CE standards.

Delivery set

Turnstile housing with built-in electronic board	1
Hub with barrier arms and mounting kit	1
RC-panel (cable length of min. 6.6 m)	1
Mounting kit	1
Documentation set	1
Optional equipment (upon request)	
WRC (consisting of a receiver and transmitters in the form of key fobs) with a range of up to 40 m	1
Intrusion detector (installed upon request at the manufacturing site)	1
Siren (alert on an unauthorized passage attempt)	1
PFG IR 10-15 anchor (SORMAT company, Finland)	4
Turnstile power supply	1

Technical specifications

Operating voltage	12±1.2 V DC
Current consumption	max. 6 A
Power consumption	max. 72 W
Overall dimensions with installed barrier arms (LxWxH)	1170x750x1020 mm
Passageway width	560 mm
Turnstile weight	max 70 kg
Package dimensions (LxWxH)	132x110x40 cm
Throughput in single passage mode	30 persons / min
Throughput in free passage mode	60 persons / min
Mean time to failure	4,000,000 passages
Mean lifetime	8 years

Connection

TTD-08A turnstile is equipped with integrated CLB.140 electronic board. All connections are made to the board contacts. The microcontroller installed on the board controls the turnstile's actuating mechanism, processes signals from optical sensors for moving the barrier arms, processes commands received from external devices, and generates signals about passages through the turnstile.

Built-in CLB electronic board contacts description by connectors			
Connector	Contact	Electrical circuit	Designation
XT1.L	1, 2,3	+12 V, Detector, GND	Intrusion detector connection
	4,5	Fire Alarm, GND	Emergency unlocking input
	6	GND	Power supply negative terminal
	7, 8, 9	Unlock A, Stop, Unlock B	Turnstile control inputs
	10, 11, 12	Led A, Led Stop, Led B	RC-panel indication outputs
XT1.H	1	GND	Power supply negative terminal
	2	+12 V	"Siren" device power supply positive terminal
	3, 4	Alarm 1, Alarm 2	Alarm relay contacts
	5	Common	Common contact for PASS A, PASS B, Ready, Det Out signals
	6	PASS A	PASS A relay contact (passage in the direction A)
	7	PASS B	PASS B relay contact (passage in the direction B)
	8	Ready	Ready relay contact
	9	Det Out	Det Out relay contact
XT3	1, 2	+12 V, GND	Connecting an external power supply
XT4	1, 2,3	NO, C, NC	Light A relay contacts – connection of the remote indicator for direction A (not included in the standard delivery set)
XT5	1, 2, 3	NO, C, NC	Light B relay contacts – connection of the remote indicator for direction B (not included in the standard delivery set)
XT6	1, 2, 3	"L+", "L-"	AntiPanic relay contacts for connecting electromagnet of the automatic anti-panic function device
X1		LED	X1 (LED) connector for connecting indication board cable
X2		SENS	X2 (SENS) connector for connecting rotation optical sensor unit cable
X3		MOTOR	X3 (MOTOR) connector for connecting control mechanism cable with an electromechanical locking device



TTD-08A Box tripod turnstile

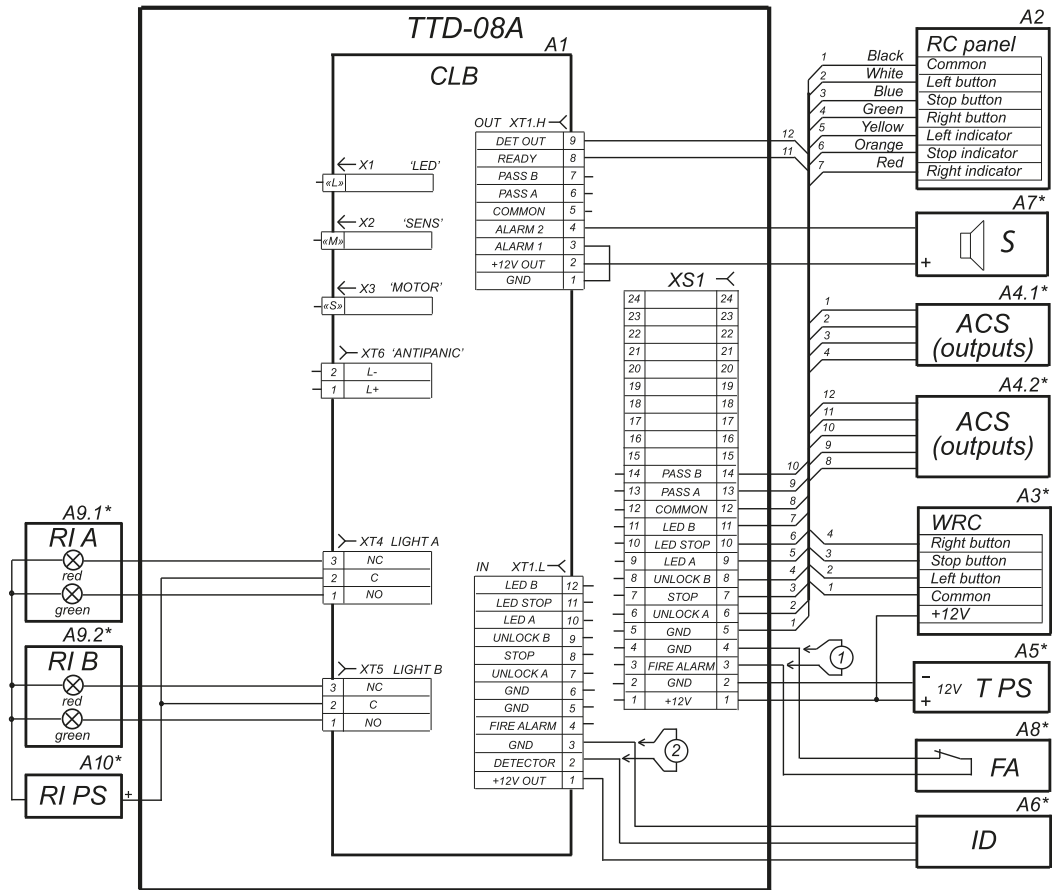

Wiring diagram of external connections to the CLB Board

Diagram description	
Item	Description
A1	CLB.140 control board
A2	RC-panel
A3*	WRC
A4*	Access control system
A5*	Turnstile power supply
A6*	Intrusion detector
A7*	12V DC siren
A8*	Device that gives the emergency passage opening command (FA)
A9.1*, A9.2*	Remote indicators
A10*	Power supply for remote indicators
XS1	PSK1/12 (12) Klemсан x 2 terminal block
1	Jumper wire if there is no FA device (A8)
2	Jumper wire if there is no intrusion detector (A6)
3	Control board indication cable
4	Turnstile cover indication cable

* The equipment is not included in the standard delivery set

Operation algorithm

The turnstile can operate from the RC-panel (included in the delivery set), WRC or ACS controller.

Operation is performed by applying a low-level signal to Unlock A, Stop and Unlock B contacts relative to the GND contact. The response to these signals depends on the control mode selected by the J1 jumper wire.

Pulse control mode is when a pulse is applied to the Unlock A (B) input, the turnstile will automatically open for a single passage in the selected direction. The waiting time for the passage being completed does not depend on the duration of the control pulse and lasts 5 seconds. Sending a pulse to the Stop input locks both passage directions. Simultaneous sending of pulses to Unlock A (B) and Stop inputs places the turnstile in the "Free passage" mode in the selected direction.

It is recommended to use pulse mode during operation from RC-panel or WRC. The orientation of RC-panel buttons (if the turnstile is facing the operator not with the front side, but with the rear side) can be changed by swapping the wires from the RC-panel that are connected to the Unlock A and Unlock B, as well as Led A and Led B, respectively.

Potential control mode is when the control signal is applied to the Unlock A (B) input, the turnstile remains unlocked in the selected direction during the entire holding signal time. Sending control signal to the Stop input locks both passage directions regardless of the signals at the Unlock A (B) inputs.

Potential mode is recommended during operation from the ACS controller.

Regardless of the selected control mode, PASS A or PASS B signals are generated when moving the barrier arms in one direction or the other. These signals can inform the ACS controller of the fact of passage.

Emergency passage opening is performed by removing a low-level signal from the Fire Alarm contact relative to the GND contact.

Note:

When operating the turnstile from the ACS controller, it is recommended to connect the RC-panel to the ACS controller.

The maximum allowed cable length of the RC-panel (ACS controller) is 40 meters.

The maximum allowed cable length of the power supply depends on its cross section and must be:

- 1.5 mm² cable cross-section – 10 m
- 2.5 mm² cable cross-section – 15 m

There is a possibility to install PERCo card readers inside the turnstile housing. If third-party readers are installed, they must comply to the following technical requirements:

- overall dimensions – max. 135x90x30 mm
- identifiers reading range – min. 50 mm



TTD-08A Box tripod turnstile

Example of connection to the ACS

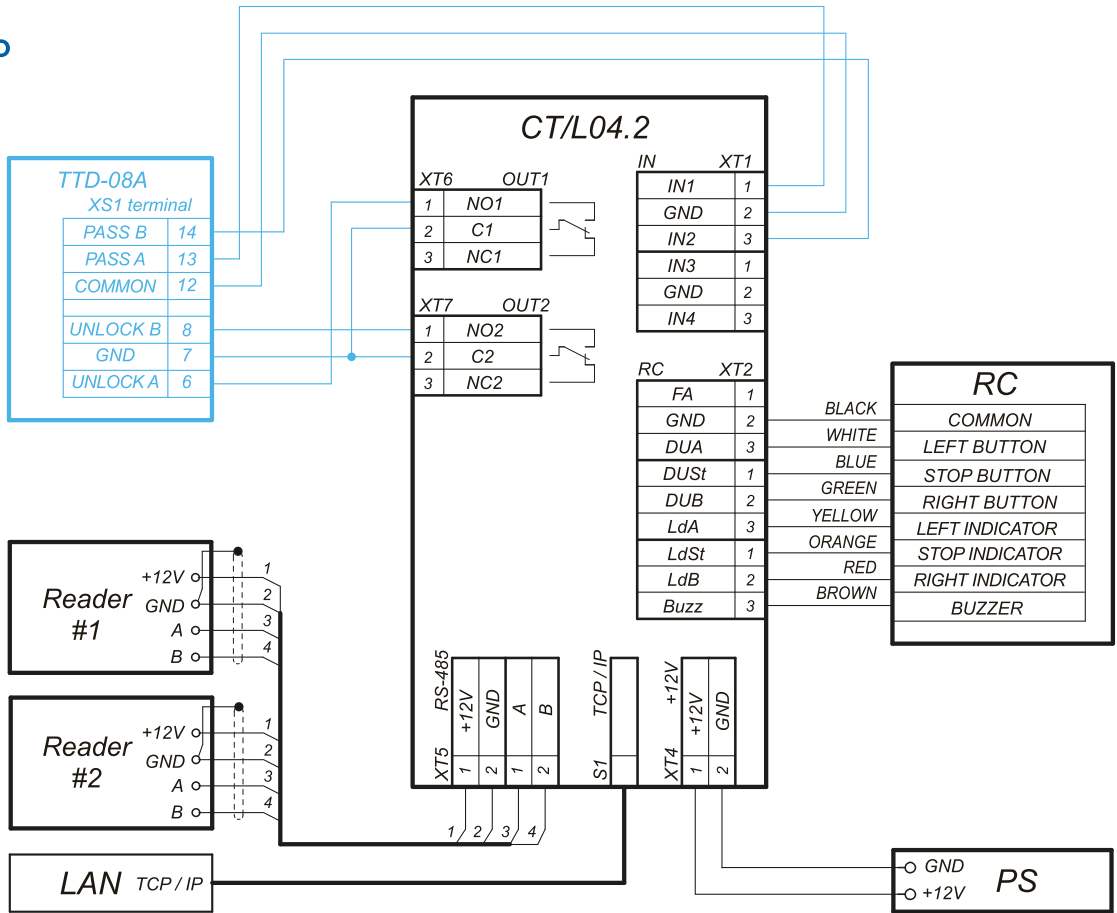

1 - jumper wire, installed if there is no FA device

Example of turnstile connection to the ACS controller

Overall dimensions

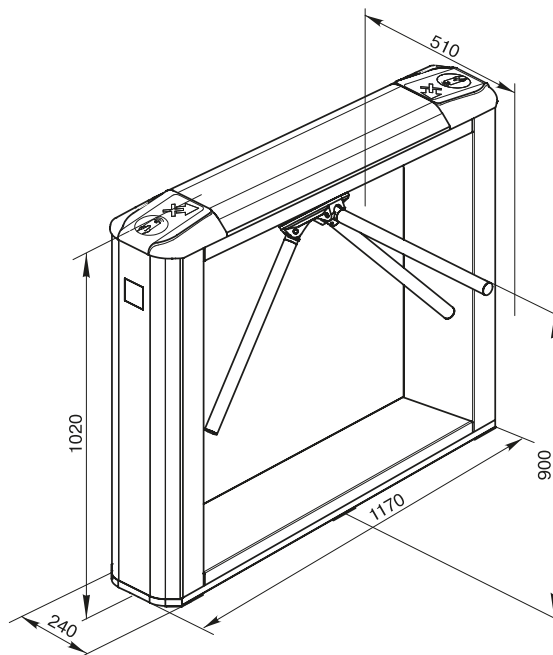

Overall dimensions



Mounting

Foundation requirements: concrete (not lower than 400 grade), stone, etc. foundation of at least 150 mm thick, use reinforcing elements (400x400x300 mm) when installing turnstile housing on a less steady foundation.

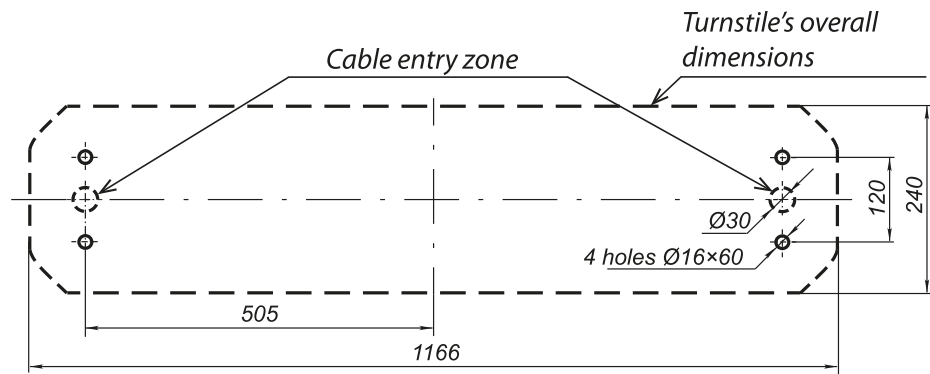

Hole marking for turnstile mounting and cable entry zone

Passage zone modeling

When the turnstile is operated from ACS, it is recommended to place card readers in the turnstile housing. BH01 0-03 bracket is used for mounting readers on the BH02 series railings.

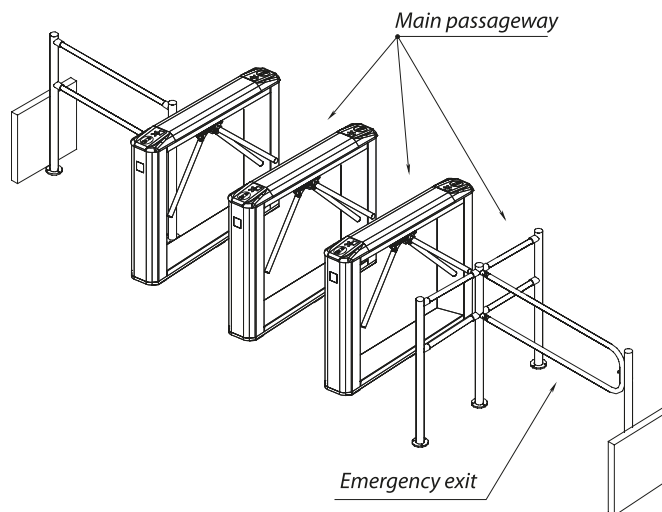

Example of an entrance zone project

Warranty

The warranty period is 5 (five) years commencing from the date of sale, unless otherwise determined in the delivery contract of the Product. In case of sale and installation of the equipment by authorized PERCo dealers and service centers, the warranty starts from the date of commissioning.

Should there be no date of sale on the warranty card, the warranty period shall commence from the date of manufacture specified in the Certificate and on the Product label.



TB01.1A Box tripod turnstile



+50
+1
temperature range

12V
operating voltage

72 W
power consumption

2
passage direction

30
persons/min

Anti-panic barrier arms

EMM/HID
card format

2
readers

Turnstiles, gates and railings

Application

TB01.1A turnstile is an electromechanical box tripod turnstile with built-in readers and automatic anti-panic barrier arms designed for indoor operation.

The delivery set includes an RC-panel, the orientation of the RC-panel buttons relative to the passage directions is set when connecting to the turnstile. It is recommended to install one turnstile per 500 people working the same shift and based on a maximum working load of 30 persons/min. Turnstiles can be equipped with railings.



Automatic anti-panic barrier arms

Operating modes

The turnstile provides passage control in two directions, the turnstile operating mode may be set independently for each passage direction. Supported operating modes:

- passage denial in both directions
- single passage in one direction and passage denial in the other direction
- single passage in both directions
- free passage in one direction and passage denial in the other direction
- free passage in one direction and single passage in the other direction
- free passage in both directions



RC-panel

When the power is turned off, the turnstile barrier arm falls down, and both directions become open for free passage.

Main features

- turnstile is equipped with two proximity readers (EMM/HID) featuring Wiegand interface
- operation of the turnstile from RC-panel, WRC, ACS
- front-end covers with built-in readers feature pictogram indication of the readers and turnstile operating modes
- safe voltage – max. 14 V
- power consumption - max. 72 W (72 W – within 5 seconds after powering the turnstile or removing the Fire Alarm signal; the power consumption is max. 30 W during the rest of the operation)

Turnstiles, gates and railings



- when a command is given by the emergency passage opening device, as well as when the turnstile power supply is turned off, the passage is automatically opened by moving the barrier arm to the vertical position
- after restoring the turnstile supply voltage or removing the Fire Alarm signal, the barrier arm is moved to the working position manually
- automatic reset of the barrier arms to the home position after each passage
- damping device provides smooth silent operation
- barrier arm rotation optical sensors record correctly the fact of passage
- built into the turnstile housing electronic board
- there is a possibility to install ACS controller board inside the housing
- two control modes – pulse and potential
- galvanically isolated outputs
- Fire Alarm control input that allows connecting the emergency unlocking device
- relay outputs for connecting additional external indicators of the passage grant / denial
- installing several turnstiles in a row allows arranging passage zone without additional railings.
- turnstile is manufactured in the same design as TBC01.1A with integrated card capture reader

Built-in reader



Pictogram indication block

Design

Turnstile housing – stainless steel with plastic inserts. Barrier arms – stainless steel.

Operating conditions

The product with regard to resistance to environmental exposure complies with GOST 15150-69 category NF4 (operation in premises with climate control).

Operation of the turnstile is allowed at ambient temperature from +1 °C to +50 °C and relative air humidity up to 80% at + 25 °C.

It is a serially produced product certified for compliance with applicable Russian and European CE standards.

Delivery set

Turnstile housing with installed hub with anti-panic barrier arm, proximity readers, passage indicators.	1
RC-panel (cable length of 6.6 m)	1
S 2.5 Allen key for top cover lock	1
Key to the side panels	2
Mounting kit	1
Documentation set	1
Optional equipment (upon request)	
WRC (consisting of a receiver and transmitters in the form of key fobs) with a range of up to 40 m	1
PFG IR 10-15 anchor (SORMAT company, Finland)	4
Turnstile power supply	1



TB01.1A Box tripod turnstile

Technical specifications

Operating voltage	12±1.2 V DC	
Current consumption	max. 6.0 A	
Power consumption	max. 72 W	
Number of readers	2	
Card reading distance at the nominal operating voltage	for HID cards	6 cm
	for EMM cards	8 cm
Throughput rate	in the single passage mode	30 persons / min
	in the free passage mode	60 persons / min
Mean time to failure	4,000,000 passages	
Overall dimensions with installed barrier arms (LxWxH)	1170x750x1030 mm	
Passageway width	560 mm	
Turnstile weight	max. 72 kg	
Package dimensions (LxWxH)	128x39x110 cm	

Connection

TB01.1A turnstile is equipped with integrated CLB.140 electronic board and two built-in readers with Wiegand interface.

Integrated CLB.140 electronic board contacts description by connectors.

Integrated electronic board contacts description by connectors			
Connector	Contact	Electrical circuit	Designation
XT1.L	1, 2, 3	+12 V, Detector, GND	Intrusion detector connection
	4, 5	Fire Alarm, GND	Emergency unlocking input
	6	GND	Power supply negative terminal
	7, 8, 9	Unlock A, Stop, Unlock B	Turnstile control inputs
	10, 11, 12	Led A, Led Stop, Led B	RC-panel indication outputs
XT1.H	1	GND	Power supply negative terminal
	2	+12 V	"Siren" device power supply positive terminal
	3, 4	Alarm 1, Alarm 2	Alarm relay contacts
	5	Common	Common contact for PASS A, PASS B, Ready, Det Out signals
	6	PASS A	PASS A relay contact (passage in the direction A)
	7	PASS B	PASS B relay contact (passage in the direction B)
	8	Ready	Ready relay contact
	9	Det Out	Det Out relay contact
XT3	1, 2	+12 V, GND	Connecting an external power supply
XT4	1, 2, 3	NO, C, NC	Light A relay contacts – connection of the remote indicator for direction A (not included in the standard delivery set)
XT5	1, 2, 3	NO, C, NC	Light B relay contacts – connection of the remote indicator for direction B (not included in the standard delivery set)
XT6	1, 2, 3	"L+", "L-"	AntiPanic relay contacts for connecting electromagnet of the automatic anti-panic function device
X1		LED	X1 (LED) connector for connecting indication board cable
X2		SENS	X2 (SENS) connector for connecting rotation optical sensor unit cable
X3		MOTOR	X3 (MOTOR) connector for connecting control mechanism cable with an electromechanical locking device

Turnstiles, gates and railings

Integrated CLB.140 electronic board is installed on the bracket inside the turnstile housing. Contacts for external power supply, contacts for built-in readers and card capture reader control lines are routed to this bracket.

Terminal block contacts description for connecting readers and card capture reader.

Description of the X1.2 terminal block contacts "Connection of a reader"		
Contact	Electrical circuit	Application
3, 4	R0:D0, R0:D1	Wiegand interface lines of the reader 1
5, 6	R0:Led Red R0:Led Green	Indication control of the reader 1 *
7	R0:Beeper	Sound signal control of the reader 1
8	GND & Shield	Common cable and cable shield of the readers 1
9	GND & Shield	Common cable and cable shield of the readers 2
10	R1:Beeper	Sound signal control of the reader 2
11, 12	R1:Led Red R1:Led Green	Indication control of the reader 2 *
13, 14	R1:D0, R1:D1	Wiegand interface lines of the reader 2

* By default, reader indication control lines (pictogram Indicators on the front-end covers) are connected to the remote Indicators control outputs of the CLB.140 board. It allows indicating the current operating mode of the turnstile. If necessary, the reader indication control lines can be reconnected to the corresponding ACS controller outputs.

See figures below for external connection layouts and TBO1.1A turnstile wiring diagram.



TB01.1A Box tripod turnstile

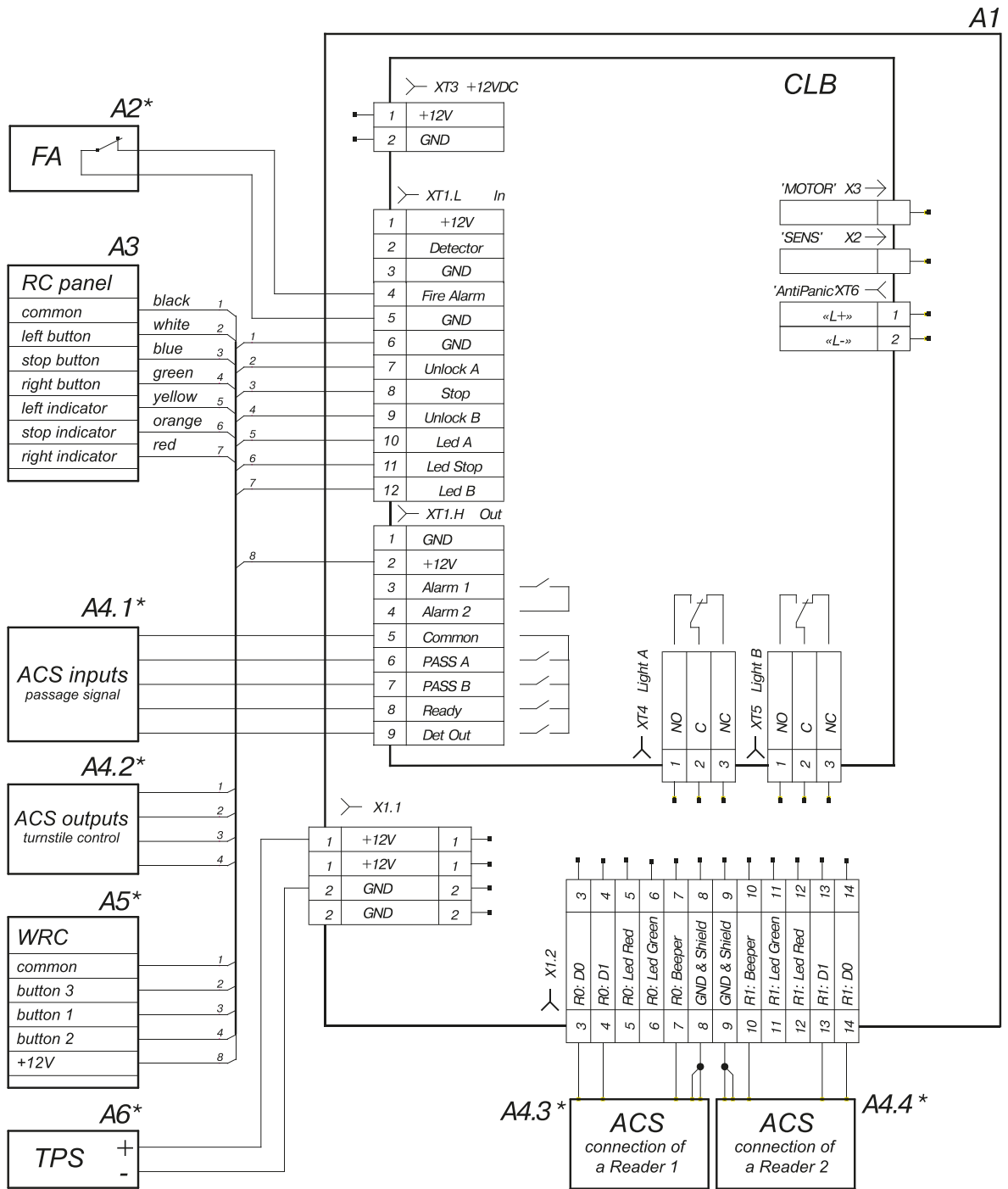

Wiring diagram of TB01.1A and optional equipment

Wiring diagram description	
Item	Description
A1	Bracket with control board and terminal blocks
A2*	Device that gives an emergency unlocking command
A3	RC-panel
A4*	Access control system (ACS controller)**
A5*	WRC
A6*	Turnstile power supply

* The equipment is not included in the standard delivery set

** Bracket dimensions for installing ACS controller board – 205x150 mm. The maximum height of the ACS controller board – 35 mm.

Operation algorithm

The turnstile can operate from the RC-panel (included in the delivery set), WRC or ACS controller.

Operation is performed by applying a low-level signal to Unlock A, Stop and Unlock B contacts relative to the GND contact. The response to these signals depends on the control mode selected by the J1 jumper wire.

Pulse control mode is when a pulse is applied to the Unlock A (B) input, the turnstile will automatically open for a single passage in the selected direction. The waiting time for the passage being completed does not depend on the duration of the control pulse and lasts 5 seconds. Sending a pulse to the Stop input locks both passage directions. Simultaneous sending of pulses to Unlock A (B) and Stop inputs places the turnstile in the "Free passage" mode in the selected direction.

Pulse mode is recommended during operation from the RC-panel. The orientation of RC-panel buttons (if the turnstile is facing the operator not with the front side, but with the rear side) can be changed by swapping the wires from the RC-panel that are connected to the Unlock A and Unlock B, as well as Led A and Led B, respectively.

Potential control mode is when the control signal is applied to the Unlock A (B) input, the turnstile remains unlocked in the selected direction during the entire holding signal time. Sending control signal to the Stop input locks both passage directions regardless of the signals at the Unlock A (B) inputs.

Potential mode is recommended during operation from the ACS controller.

Regardless of the selected control mode, PASS A or PASS B signals are generated when moving the barrier arms in one direction or the other. These signals can inform the ACS controller of the fact of passage in the selected direction.

Emergency passage opening is performed by removing a low-level signal from the Fire Alarm contact relative to the GND contact.

Note:

When operating the turnstile from the ACS controller, it is recommended to connect the RC-panel to the ACS controller.

By default, Wiegand-26 is set as data output format for readers. There is a possibility to change the format for Wiegand, Wiegand-37 or Wiegand-42 when installing. Setting one or another data output format changes only data output format and does not interfere with other card formats reading.

The maximum allowed cable length of the RC-panel (ACS controller) is 40 meters.

The maximum allowed cable length of the power supply depends on its cross section and must be:

- 1.5 mm² cable cross-section – 10 m
- 2.5 mm² cable cross-section – 15 m



TB01.1A Box tripod turnstile

Overall dimensions

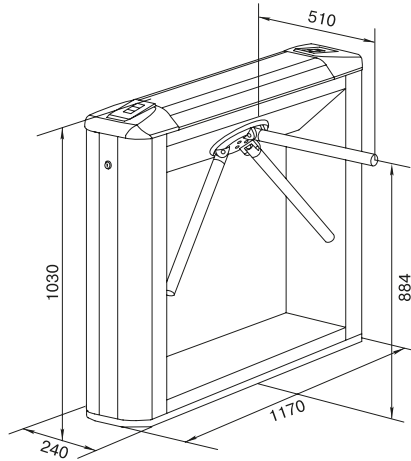

TB01.1A turnstile overall dimensions

Mounting

Foundation requirements: concrete (grade 400 or higher), stone or similar foundations of at least 150 mm thick. For the installation of the turnstile on a less steady foundation it is recommended to apply reinforcing elements (550×550×200 mm).

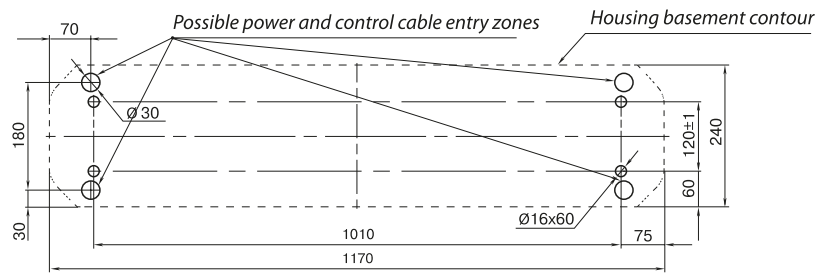

Hole marking

Passage zone modeling

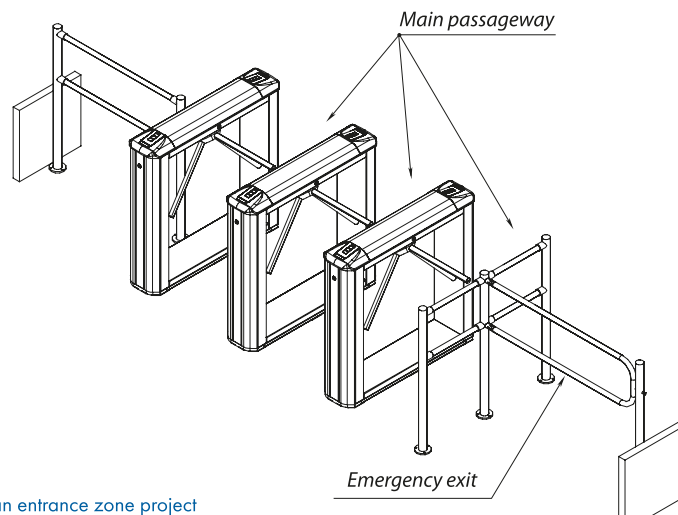

Example of an entrance zone project

Warranty

The warranty period is 5 (five) years commencing from the date of sale, unless otherwise determined in the delivery contract of the Product. In case of sale and installation of the equipment by authorized PERCo dealers and service centers, warranty starts from the date of commissioning.

Should there be no date of sale on the warranty card, the warranty period shall commence from the date of manufacture specified in the Certificate and on the Product label.

TBC01.1A Box tripod turnstile



+50
+1
temperature range

12V
operating voltage

1
card capture reader

2
passage direction

30
persons/min

anti-panic barrier arms

EMM/HID
card format

2
readers

72W
power consumption

Application

TBC01.1A turnstile is an electromechanical box tripod turnstile with built-in readers, card capture reader and automatic anti-panic barrier arms designed for indoor operation.

The delivery set includes an RC-panel, the orientation of the RC-panel buttons relative to the passage directions is set when connecting to the turnstile. It is recommended to install one turnstile per 500 people working the same shift and based on a maximum working load of 30 persons/min. Turnstiles can be equipped with railings.

The turnstile provides passage control in two directions, turnstile operating mode may be set independently for each passage direction.



Automatic anti-panic barrier arms



RC-panel

Operating modes

Supported operating modes:

- passage denial in both directions
- single passage in one direction and passage denial in the other direction
- single passage in both directions
- free passage in one direction and passage denial in the other direction
- free passage in one direction and single passage in the other direction
- free passage in both directions

When the power is turned off, the turnstile barrier arm falls, and both directions become open for free passage.

Main features

- the turnstile is equipped with two proximity readers (EMM/HID) featuring Wiegand interface and card capture reader
- operation of the turnstile from RC-panel, WRC, ACS
- as a part of ACS, a built-in card capture reader allows capturing temporary cards upon a command from the system controller
- the turnstile design allows changing the card capture reader position
- slot of the card capture reader features a backlight that informs visitors about the need to drop the visitor card into the card capture reader
- front-end covers with built-in readers feature pictogram indication of the readers and



TBC01.1 A Box tripod turnstile

turnstile operating modes

- safe voltage – max. 14 V
- power consumption - max. 72 W (72 W – within 5 seconds after powering the turnstile or removing the Fire Alarm signal; the power consumption is max. 30 W during the rest of the operation)
- when a command is given by the emergency passage opening device, as well as when the turnstile power supply is turned off, the passage is automatically opened by moving the barrier arm to the vertical position
- after restoring the turnstile supply voltage or removing the Fire Alarm signal, the barrier arm is moved to the working position manually
- automatic reset of the barrier arms to the home position after each passage
- damping device provides smooth silent operation
- barrier arm rotation optical sensors record correctly the fact of passage
- built into the turnstile housing electronic board
- there is a possibility to install ACS controller board inside the housing
- two control modes – pulse and potential
- outputs galvanic isolation
- Fire Alarm control input that allows connecting the emergency unlocking device
- relay outputs for connecting additional external indicators of the passage grant / denial
- installing several turnstiles in a row allows arranging passage zone without additional railings.
- turnstile is manufactured in the same design as TBO1.1A

Built-in reader



Pictogram indication block

Design

Turnstile housing – stainless steel with plastic inserts. Barrier arms – stainless steel.

Operating conditions

The turnstile, with regard to resistance to environmental exposure, complies with GOST 15150-69 category NF4 (operation in premises with climate control). The operation of the turnstile is allowed at ambient temperature from +1 °C to +50°C and relative air humidity up to 80% at + 25°C.

It is a serially produced product certified for compliance with applicable Russian and European CE standards.

Delivery set

Turnstile housing with installed hub with anti-panic barrier arm, proximity readers, passage indicators and card capture reader.	1
RC-panel (cable length of 6.6 m)	1
S 2.5 Allen key for top cover lock	1
Key to the side panels	2
Key to the container of the card capture reader	2
Mounting kit	1
Documentation set	1



Technical specifications

Optional equipment (upon request)		
WRC (consisting of a receiver and two transmitters in the form of key fobs) with a range of up to 40 m	1	
PFG IR 10-15 anchor (SORMAT company, Finland)	4	
Turnstile power supply	1	
Operating voltage	12±1.2 V DC	
Current consumption	max. 6.0 A	
Power consumption	max. 72 W	
Number of readers	2	
Card reading distance at the nominal operating voltage	for HID cards	6 cm
	for EMM cards	8 cm
Throughput rate	in the single passage mode	30 persons / min
	in the free passage mode	60 persons / min
Mean time to failure	4,000,000 passages	
Overall dimensions with installed barrier arms (LxWxH)	1170x750x1030 mm	
Passageway width	560 mm	
Turnstile weight	max. 72 kg	
Package dimensions (LxWxH)	128x39x110 cm	

Connection

TBC01.1A turnstile is equipped with integrated CLB.140 electronic board and two built-in readers with Wiegand interface and card capture reader electronic board.

Integrated CLB.140 electronic board contacts description by connectors.

Integrated electronic board contacts description by connectors			
Connector	Contact	Electrical circuit	Designation
XT1.L	1, 2, 3	+12 V, Detector, GND	Intrusion detector connection
	4, 5	Fire Alarm, GND	Emergency unlocking input
	6	GND	Power supply negative terminal
	7, 8, 9	Unlock A, Stop, Unlock B	Turnstile control inputs
	10, 11, 12	Led A, Led Stop, Led B	RC-panel indication outputs
XT1.H	1	GND	Power supply negative terminal
	2	+12 V	"Siren" device power supply positive terminal
	3, 4	Alarm 1, Alarm 2	Alarm relay contacts
	5	Common	Common contact for PASS A, PASS B, Ready, Det Out signals
	6	PASS A	PASS A relay contact (passage in the direction A)
	7	PASS B	PASS B relay contact (passage in the direction B)
	8	Ready	Ready relay contact
	9	Det Out	Det Out relay contact
	XT3	1, 2	+12 V, GND
XT4	1, 2, 3	NO, C, NC	Light A relay contacts – connection of the remote indicator for direction A (not included in the standard delivery set)
XT5	1, 2, 3	NO, C, NC	Light B relay contacts – connection of the remote indicator for direction B (not included in the standard delivery set)
XT6	1, 2, 3	"L+", "L-"	AntiPanic relay contacts for connecting electromagnet of the automatic anti-panic function device



TBC01.1A Box tripod turnstile

X1	LED	X1 (LED) connector for connecting indication board cable
X2	SENS	X2 (SENS) connector for connecting rotation optical sensor unit cable
X3	MOTOR	X3 (MOTOR) connector for connecting control mechanism cable with an electromechanical locking device

Integrated CLB.140 electronic board is installed on the bracket inside the turnstile housing. Contacts for external power supply, contacts for built-in readers and card capture reader control lines are routed to this bracket.

Terminal block contacts description for connecting readers and card capture reader.

Terminal block contacts description for connecting readers and card capture reader			
Connector	Contact	Electrical circuit	Designation
X1.2	3, 4	R0:D0, R0:D1	Wiegand interface lines of the reader 1
	5, 6	R0:Led Red R0:Led Green	Indication control of the reader 1*
	7	R0:Beeper	Sound signal control of the reader 1
	8	GND & Shield	Common cable and cable shield of the readers 1
	9	GND & Shield	Common cable and cable shield of the readers 2
	10	R1:Beeper	Sound signal control of the reader 2
	11, 12	R1:Led Red R1:Led Green	Indication control of the reader 2*
	13, 14	R1:D0, R1:D1	Wiegand interface lines of the reader 2
X1.3	17	Capture card	Command to the card capture reader for card capturing
	18	GND	Common
	19	Card captured	Signal from the card capture reader on card being captured
	20	Fault	Signal from the card capture reader about container filling
	21	COM	Common for "Card captured" and "Alarm" signals

* By default, reader indication control lines (pictogram Indicators on the front-end covers) are connected to the remote Indicators control outputs of the CLB.140 board. It allows indicating the current operating mode of the turnstile. If necessary, the reader indication control lines can be reconnected to the corresponding ACS controller outputs.

See figures below for external connection layouts and TBC01.1A turnstile wiring diagram.

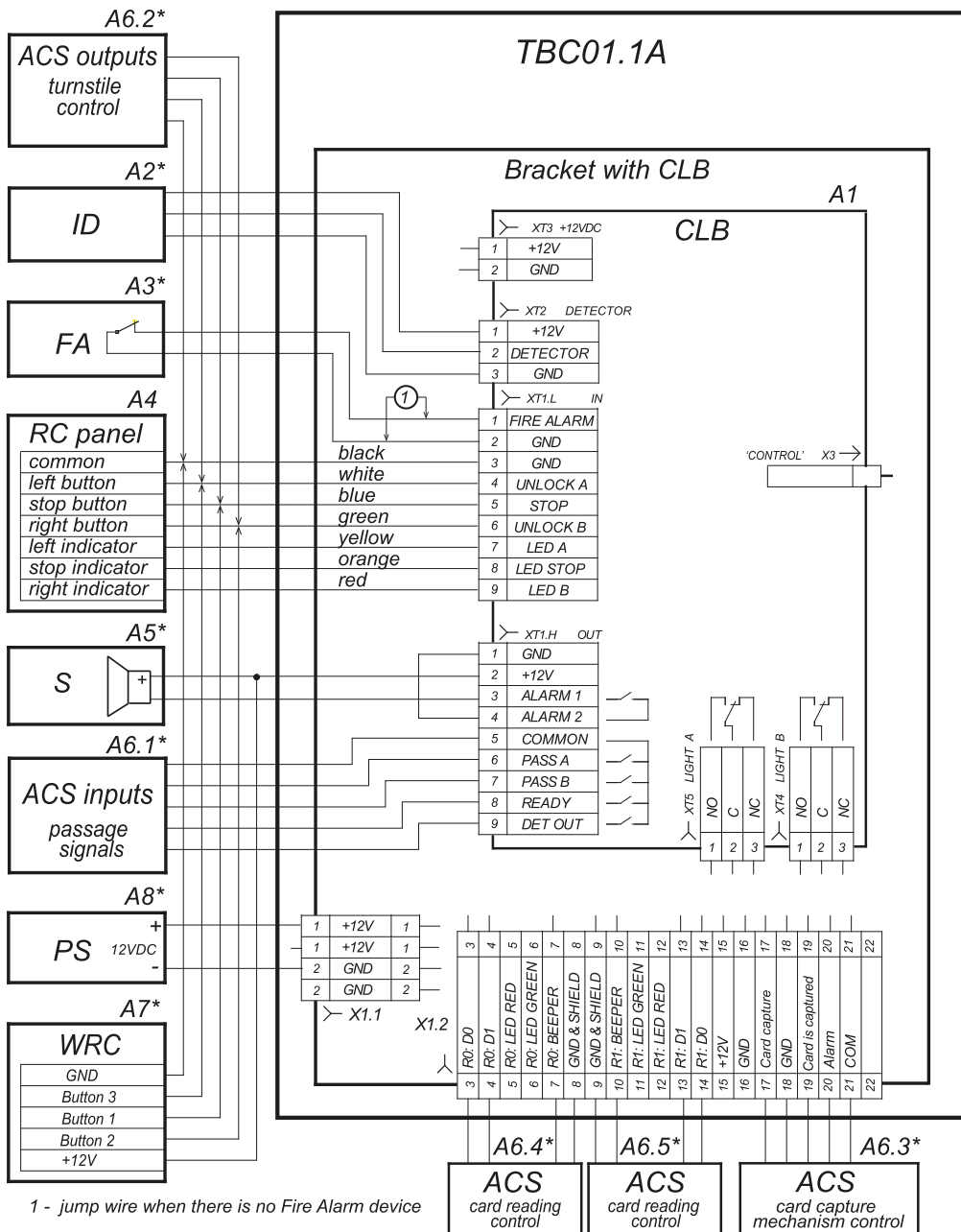

Wiring diagram of the TBC01.1A turnstile and optional equipment

Diagram description	
ITEM	DESCRIPTION
A1	Bracket with CLB board and terminal blocks
A2*	Device that gives an emergency unlocking command
A3*	RC-panel
A4	ACS controller**
A5*	WRC
A6*	Turnstile power supply

* The equipment is not included in the standard delivery set

** Bracket dimensions for installing ACS controller board – 205x150 mm. The maximum height of the ACS controller board – 35 mm



TBC01.1 A Box tripod turnstile

Operation algorithm

The turnstile can operate from the RC-panel (included in the delivery set), WRC or ACS controller.

Operation is performed by applying a low-level signal to Unlock A, Stop and Unlock B contacts relative to the GND contact. The response to these signals depends on the control mode selected by the J1 jumper wire.

Pulse control mode is when a pulse is applied to the Unlock A (B) input, the turnstile will automatically open for a single passage in the selected direction. The waiting time for the passage being completed does not depend on the duration of the control pulse and lasts 5 seconds. Sending a pulse to the Stop input locks both passage directions. Simultaneous sending of pulses to Unlock A (B) and Stop inputs places the turnstile in the "Free passage" mode in the selected direction.

Pulse mode is recommended during operation from the RC-panel. The orientation of RC-panel buttons (if the turnstile is facing the operator not with the front side, but with the rear side) can be changed by swapping the wires from the RC-panel that are connected to the Unlock A and Unlock B, as well as Led A and Led B, respectively.

Potential control mode is when the control signal is applied to the Unlock A (B) input, the turnstile remains unlocked in the selected direction during the entire holding signal time. Sending control signal to the Stop input locks both passage directions regardless of the signals at the Unlock A (B) inputs.

Potential mode is recommended during operation from the ACS controller.

Regardless of the selected control mode, PASS A or PASS B signals are generated when moving the barrier arms in one direction or the other. These signals can inform the ACS controller of the fact of passage in the selected direction.

Emergency passage opening is performed by removing a low-level signal from the Fire Alarm contact relative to the GND contact.

Note:

When operating the turnstile from the ACS controller, it is recommended to connect the RC-panel to the ACS controller.

by default, Wiegand-26 is set as data output format for readers. There is a possibility to change the format for Wiegand, Wiegand-37 or Wiegand-42 when installing. Setting one or another data output format changes only data output format and does not interfere with other card formats reading.

Built-in card capture reader is operated through the ACS controller.

Upon presenting a card to the slot of the card capture reader, the built-in reader transfers the card number to the ACS controller. If the card is subject to withdrawal, the ACS controller gives the "Capture card" command (upon this command the slot backlight is on) and is waiting for the "Card captured" command. "Card captured" signal means that the card was inserted into the card capture reader container. Afterwards, the ACS controller gives the command authorizing the passage.

Card can be inserted into the card capture reader container only when the "Capture card" is activated.

If the card presented to the reader is not subject to withdrawal, the ACS controller gives immediately the command authorizing the passage.

"Card captured" and "Fault" outputs are normally open relay contacts. "Capture card" input is controlled by "Dry contact" or "Open collector" controller outputs.

The maximum allowed cable length of the RC-panel (ACS controller) is 40 meters.

The maximum allowed cable length of the power supply depends on its cross section and must be:

- 1.5 mm² cable cross-section – 10 m
- 2.5 mm² cable cross-section – 15 m



Overall dimensions

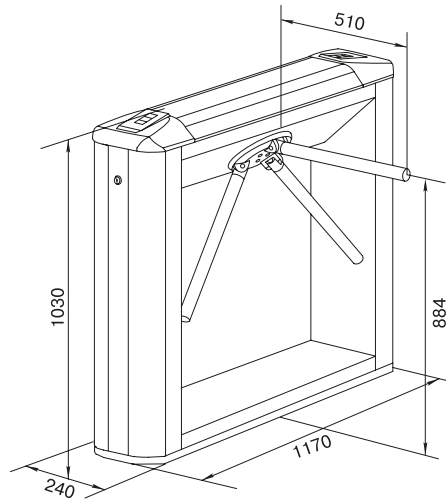

TBC01.1A turnstile overall dimensions

Mounting

Foundation requirements: concrete (grade 400 or higher), stone or similar foundations of at least 150 mm thick. For the installation of the turnstile on a less steady foundation it is recommended to apply reinforcing elements (550×550×200 mm).

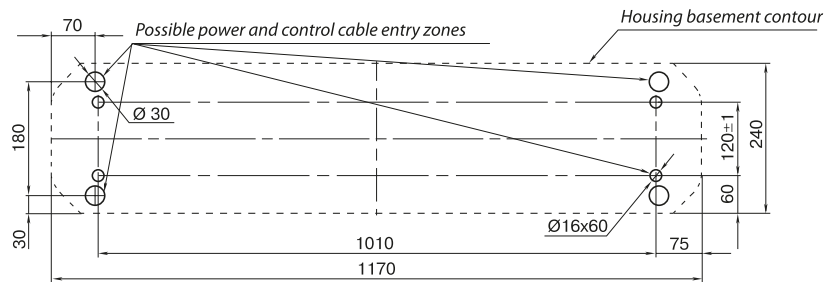

Hole marking

Passage zone modeling

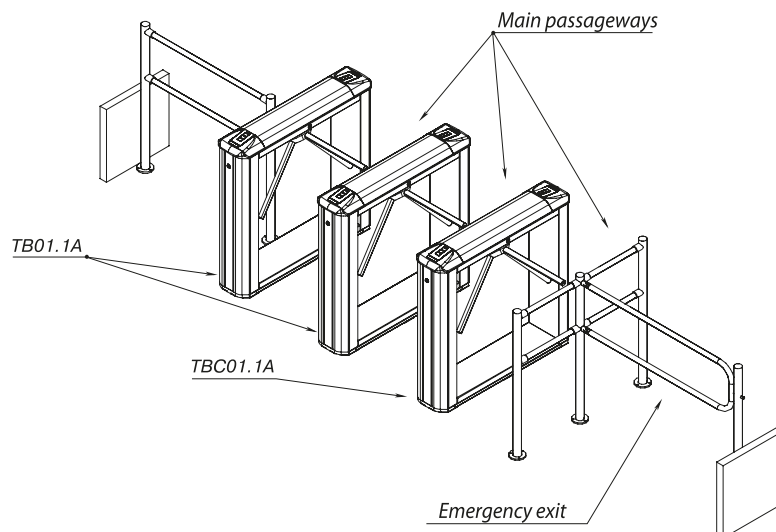

Example of an entrance zone project

Warranty

The warranty period is 5 (five) years commencing from the date of sale, unless otherwise determined in the delivery contract of the Product. In case of sale and installation of the equipment by authorized PERCo dealers and service centers, the warranty starts from the date of commissioning.

Should there be no date of sale on the warranty card, the warranty period shall commence from the date of manufacture specified in the Certificate and on the Product label.



TTD-03.1 Box tripod turnstile



+50
+1
temperature range

12V
operating voltage

2
passage direction

30
persons/min

mechanical unlocking

Application

TTD-03.1 box turnstile is a normally closed electromechanical turnstile designed for indoor operation.

The delivery set includes an RC-panel, the orientation of the RC-panel buttons relative to the passage directions is set when connecting to the turnstile. It is recommended to install one turnstile per 500 people working the same shift and based on a maximum working load of 30 persons/min. Turnstiles can be equipped with railings.



RC-panel

Operating modes

The turnstile provides passage control in two directions, turnstile operating mode may be set independently for each passage direction. Supported operating modes:

- passage denial in both directions
- single passage in one direction and passage denial in the other direction
- single passage in both directions
- free passage in one direction and passage denial in the other direction
- free passage in one direction and single passage in the other direction
- free passage in both directions

When the power is turned off, both passage directions remain as before the power loss.

Main features

- installing several turnstiles in a row allows arranging passage zone without additional railings
- operation of the turnstile from RC-panel, WRC, ACS
- built into the turnstile housing electronic board
- built into the turnstile top cover passage grant / denial indication
- radio-transparent turnstile top cover allows installing ACS proximity readers inside the housing; reader's interrogation zone is displayed in colour; there are brackets inside the housing for readers mounting



LED indication

Turnstiles, gates and railings



- safe voltage – max. 14 V
- and low power consumption – max. 8.5 W
- automatic reset of the barrier arms to the home position after each passage
- damping device provides smooth silent operation
- barrier arm rotation optical sensors record correctly the fact of passage
- integrated mechanical release lock
- possibility to connect an intrusion detector and a siren to the turnstile
- two control modes – pulse and potential
- outputs galvanic isolation
- Fire Alarm control input that allows connecting the emergency unlocking device
- relay outputs for connecting additional external indicators of the passage grant / denial

Design

Housing – stainless steel or powder coated steel. Possible housing finishes:

Item	Finish
TTD-03.1S	Polished stainless steel
TTD-03.1G	Steel, sandpaper powder coating with pearl mica effect; dark grey colour



Polished stainless steel



Steel, sandpaper powder coating with pearl mica effect; dark grey colour

Powder coating to RAL colours is available on order. Turnstile top cover is manufactured in two versions:

Top cover type	Design
C-03G blue	Artificial stone, blue colour, two built-in indicators
C-03G black	Artificial stone, black colour, two built-in indicators



Blue colour



Black colour

The turnstile can be equipped with two types of barrier arms:

Item	Description
AS-01	Standard barrier arms
AA-01	Mechanical anti-panic barrier arms



Mechanical anti-panic barrier arms

Specify turnstile, top cover and barrier arms models when ordering.



TTD-03.1 Box tripod turnstile

Operating conditions

The turnstile, with regard to resistance to environmental exposure, complies with GOST 15150-09 category NF4 (operation in premises with climate control). The operation of the turnstile is allowed at ambient temperature from +1 °C to +50 °C and relative air humidity up to 80% at + 25 °C.

It is a serially produced product certified for compliance with applicable Russian and European CE standards.

Delivery set

Turnstile housing	1
Turnstile top cover (choose colour when ordering)	1
Barrier arm (model to be chosen when ordering)	3
RC-panel (cable length of 6.6 m)	1
Key to mechanical release lock	2
Key to the top cover lock	2
Documentation set	1
Optional equipment (upon request)	
WRC (consisting of a receiver and two transmitters in the form of key fobs) with a range of up to 40 m	1
Intrusion detector (installed upon request at the manufacturing site)	1
Siren (for signalling that an unauthorized passage has been attempted)	1
PFG IR 10-15 anchor (SORMAT company, Finland)	4
Turnstile power supply	1

Technical specifications

Operating voltage	12±1.8 V DC	
Current consumption	max. 700 mA	
Power consumption	max. 8.5 W	
Overall dimensions with installed barrier arms (LxWxH)	1083x684x1000 mm	
Passageway width	500 mm	
Turnstile weight	69 kg	
Package dimensions (LxWxH)	box #1	121x38x113 cm
	box #2	119x36x17 cm
Throughput rate	in the single passage mode	30 persons / min
	in the free passage mode	60 persons / min
Mean time to failure	4,000,000 passages	

Connection

TTD-03.1 turnstile is equipped with integrated CLB electronic board. Connection procedure is stated in the "TTR-04.1 Tripod turnstile" section.



Overall dimensions

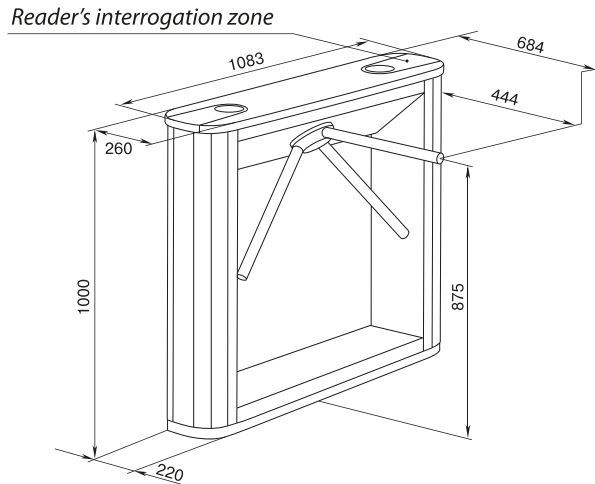

Overall dimensions

Mounting

Foundation requirements: concrete (grade 400 or higher), stone or similar foundations of at least 150 mm thick. For the installation of the turnstile on a less steady foundation it is recommended to apply reinforcing elements (400×400×400 mm).

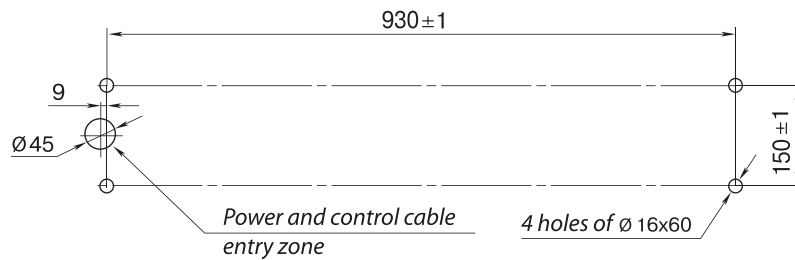

Hole marking

Passage zone modeling

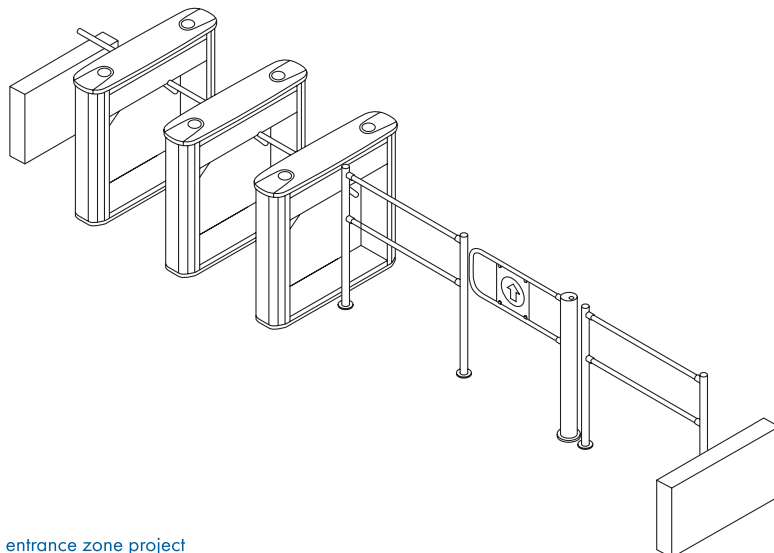

Example of an entrance zone project

Warranty

The warranty period is 5 (five) years commencing from the date of sale, unless otherwise determined in the delivery contract of the Product. In case of sale and installation of the equipment by authorized PERCo dealers and service centers, the warranty starts from the date of commissioning.

Should there be no date of sale on the warranty card, the warranty period shall commence from the date of manufacture specified in the Certificate and on the Product label.



TTD-03.2 Box tripod turnstile

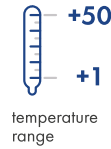

temperature range



operating voltage



passage direction



persons/min



mechanical unlocking

Application

TTD-03.2 box turnstile is a normally closed electromechanical turnstile designed for indoor operation.

The delivery set includes an RC-panel, the orientation of the RC-panel buttons relative to the passage directions is set when connecting to the turnstile. It is recommended to install one turnstile per 500 people working the same shift and based on a maximum working load of 30 persons/min. Turnstiles can be equipped with railings.



RC-panel

Operating modes

The turnstile provides passage control in two directions, turnstile operating mode may be set independently for each passage direction. Supported operating modes:

- passage denial in both directions
- single passage in one direction and passage denial in the other direction
- single passage in both directions
- free passage in one direction and passage denial in the other direction
- free passage in one direction and single passage in the other direction
- free passage in both directions

When the power is turned off, both passage directions remain as before the power loss.

Main features

- installing several turnstiles in a row allows arranging passage zone without additional railings.
- operation of the turnstile from RC-panel, WRC, ACS
- built into the turnstile housing electronic board
- built into the turnstile top cover passage grant / denial indication
- safe voltage – max. 14 V
- and low power consumption – max. 8.5 W
- automatic reset of the barrier arms to the home position after each passage
- damping device provides smooth silent operation
- barrier arm rotation optical sensors record correctly the fact of passage



LED indication

Turnstiles, gates and railings



- integrated mechanical release lock
- possibility to connect an intrusion detector and a siren to the turnstile
- two control modes – pulse and potential
- outputs galvanic isolation
- Fire Alarm control input that allows connecting the emergency unlocking device
- relay outputs for connecting additional external indicators of the passage grant / denial

Design

Housing – stainless steel or powder coated steel. Possible housing finishes:

Item	Finish
TTD-03.2S	Polished stainless steel
TTD-03.2G	Steel, sandpaper powder coating with pearl mica effect; dark grey colour



Polished stainless steel



Steel, sandpaper powder coating with pearl mica effect; dark grey colour

Powder coating to RAL colours is available on order. Turnstile top cover – polished stainless steel.

Turnstile can be equipped with two types of the barrier arms:

Item	Description
AS-01	Standard barrier arms
AA-01	Mechanical anti-panic barrier arms



Mechanical anti-panic barrier arms

Specify top cover and barrier arms models when ordering.

Operating conditions

Turnstile, with regard to resistance to environmental exposure, complies to GOST 15150-69 category NF4 (operation in premises with climate control). Operation of the turnstile is allowed at ambient temperature from +1 °C to +50 °C and relative air humidity up to 80% at + 25 °C (non-condensing).

It is a serially produced product certified for compliance with applicable Russian and European CE standards.



TTD-03.2 Box tripod turnstile

Delivery set

Turnstile housing	1
Turnstile top cover	1
Barrier arm (model to be chosen when ordering)	3
RC-panel (cable length of 6.6 m)	1
Key to mechanical release lock	2
Key to the top cover lock	2
Documentation set	1
Optional equipment (upon request)	
WRC (consisting of a receiver and two transmitters in the form of key fobs) with a range of up to 40 m	1
Intrusion detector (installed upon request at the manufacturing site)	1
Siren (for signalling that an unauthorized passage has been attempted)	1
PFG IR 10-15 anchor (SORMAT company, Finland)	4
Turnstile power supply	1

Technical specifications

Operating voltage	12±1.8 V DC	
Current consumption	max. 700 mA	
Power consumption	max. 8.5 W	
Overall dimensions with installed barrier arms (LxWxH)	980x664x1010 mm	
Passageway width	500 mm	
Turnstile weight	65 kg	
Package dimensions (LxWxH)	114x38x109 cm	
Throughput rate	in the single passage mode	30 persons / min
	in the free passage mode	60 persons / min
Mean time to failure	4,000,000 passages	

Connection

TTD-03.2 turnstile is equipped with integrated CLB electronic board. Connection procedure is stated in the "TTR-04.1 Tripod turnstile" section (see page 248)



Overall dimensions

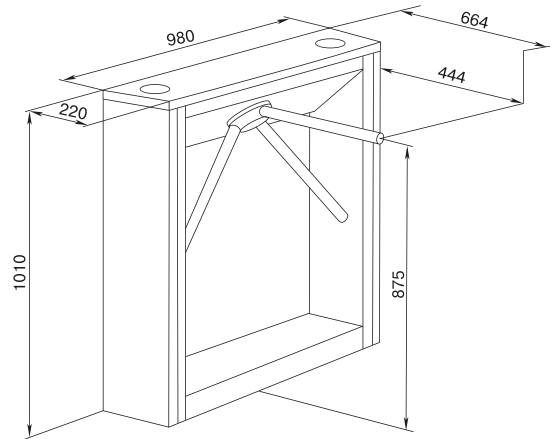

Overall dimensions

Mounting

Foundation requirements: concrete (grade 400 or higher), stone or similar foundations of at least 150 mm thick. For the installation of the turnstile on a less steady foundation it is recommended to apply reinforcing elements (400×400×400 mm).

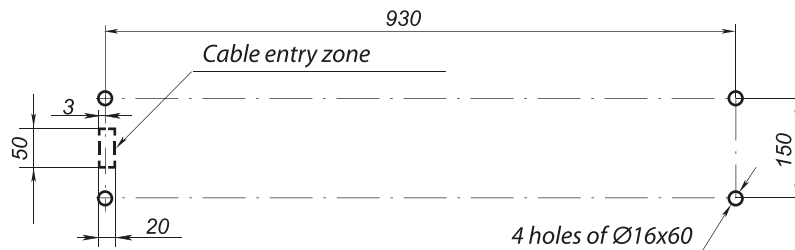

Hole marking

Passage zone modeling

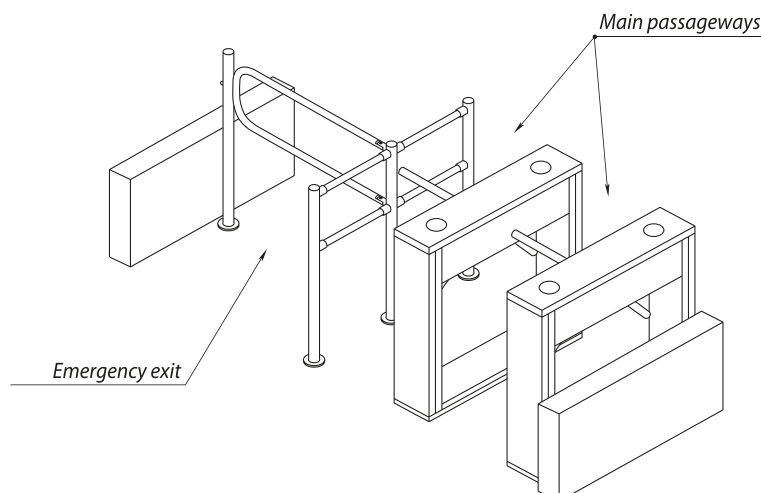

Example of an entrance zone project

Warranty

The warranty period is 5 (five) years commencing from the date of sale, unless otherwise determined in the delivery contract of the Product. In case of sale and installation of the equipment by authorized PERCo dealers and service centers, the warranty starts from the date of commissioning.

Should there be no date of sale on the warranty card, the warranty period shall commence from the date of manufacture specified in the Certificate and on the Product label.



WMD-06 Motorized gate



+50
+1
temperature range

24V
operating voltage

105 W
power consumption

2
passage direction

12
persons/min

anti-panic barrier arms

M
motor drive

Turnstiles, gates and railings

Application

WMD-06 gate is a normally open electromechanical gate designed for indoor operation. It is an elegant solution for entrance points of banks, administrative buildings, business centers and other sites with the highest requirements for design and comfort. WMD-06 gate can be used to arrange VIP entrances, emergency exits, access for people with limited mobility and for carrying bulky items.

WMD-06 swing gate can be installed both together with other PERCo turnstiles and also can operate as a standalone unit. The delivery set includes an RC-panel; the orientation of the RC-panel buttons relative to the directions of passage is set when connecting to the swing gate.



RC-panel

Operating modes

Operating from the RC-panel, the swing gate supports three operating modes:

- passage denial
- single passage
- free passage

"Passage denial" is the initial state of the swing gate. When the gate is deenergized, the swing panel rotates freely 90° in both directions.

Main features

- operation from RC-panel, WRC, ACS
- motor drive integrated into the gate post swings 90° in the set direction and resets smoothly to the home position after the passage
- swing gate is equipped with encoder that allows registering correctly the fact of swing panel opening when the gate is operated as a part of ACS
- built into the swing gate housing control board
- safe voltage – max. 27 V
- power consumption – max. 105 W



- Fire Alarm control input that allows connecting the emergency unlocking device
- when the emergency unlocking device gives a command, the gate drive opens the swing panel in the direction chosen by the user
- when the gate is de-energized, the swing panel rotates freely 90° in both directions
- after restoring the swing gate supply voltage or removing the Fire Alarm signal, the swing panel is moved to the "Closed" position.
- two control modes – pulse and potential
- outputs galvanic isolation
- relay outputs for connecting additional external indicators of the passage grant / denial
- for users' safety a matted stripe is applied on the upper part of the glass swing panel

Design

Gate post – polished stainless steel. Swing panel – 10 mm tempered glass.
The swing gate is available in two versions depending on the width of panels.

Swing panel	Description
AGG-650	650 mm swing panel
AGG-900	900 mm swing panel

Operating conditions

The swing gate, with regard to resistance to environmental exposure, complies with GOST 15150- 69 category U4 (operation in premises with climate control).

Operation of the swing gate is allowed at ambient temperature from +1°C to +50°C and relative air humidity up to 70% at + 27°C.

It is a serially produced product certified for compliance with applicable Russian and European CE standards.

Delivery set

Gate post	1
Glass swing panel	1
RC-panel (cable length of min. 6.6 m)	1
Mounting kit	1
Panels fasteners kit	1
Documentation set	1
Optional equipment (upon request)	
WRC (consisting of a receiver and two transmitters in the form of key fobs) with a range of up to 40 m	1
Power supply (rated operating voltage 24 V DC, current - min. 4A)	1

Technical specifications

Operating voltage	24 – 2.4 V BC	
Current consumption	max. 4.4 A	
Power consumption	max. 105 W	
Overall dimensions (LxWxH)	with 650 mm swing panel	795x147x1012 mm
	with 900 mm swing panel	1045x147x1012 mm
Passageway width	with 650 mm swing panel	700 mm
	with 900 mm swing panel	950 mm



WMD-06 Motorized gate

Swing gate weight	with 650 mm swing panel	max. 37 kg
	with 900 mm swing panel	max. 41 kg
Package dimensions (L×W×H)	Swing gate post with RC-panel	121×23×26 cm
	650 mm swing panel	96×12×90 cm
	900 mm swing panel	121×12×90 cm
Throughput rate	12 persons / min	
Mean time to failure	min. 500,000 passages	

Connection

The WMD-06 swing gate is equipped with a control board; all connections are made to the board contacts.

Control board contacts description by connectors

Connector	Contact	Electrical circuit	Designation
XT1	1, 2	+24 V, GND	External power supply connection
	3, 4, 5	NO, C, NC	Light A relay contacts – connection of a remote indicator for direction A (not included in the standard delivery set)
	6, 7, 8	NO, C, NC	Light B relay contacts – connection of the remote indicator for direction B (not included in the standard delivery set)
	9	+12 V	WRC power supply positive terminal
	10	GND	Power supply negative terminal
	11	Common	Common contact for PASS A, PASS B signals
	12	PASS A	PASS A relay contact (passage in the direction A)
XT2	13	PASS B	PASS B relay contact (passage in the direction B)
	1, 2	Fire Alarm, GND	Emergency unlocking input
	3	GND	Power supply negative terminal
	4, 5, 6	Unlock A, Stop, Unlock B	Turnstile control inputs
	7, 8, 9	Led A, Led Stop, Led B	RC-panel indication outputs
10	Led A, Led Stop, Led B	RC-panel sound signal output	

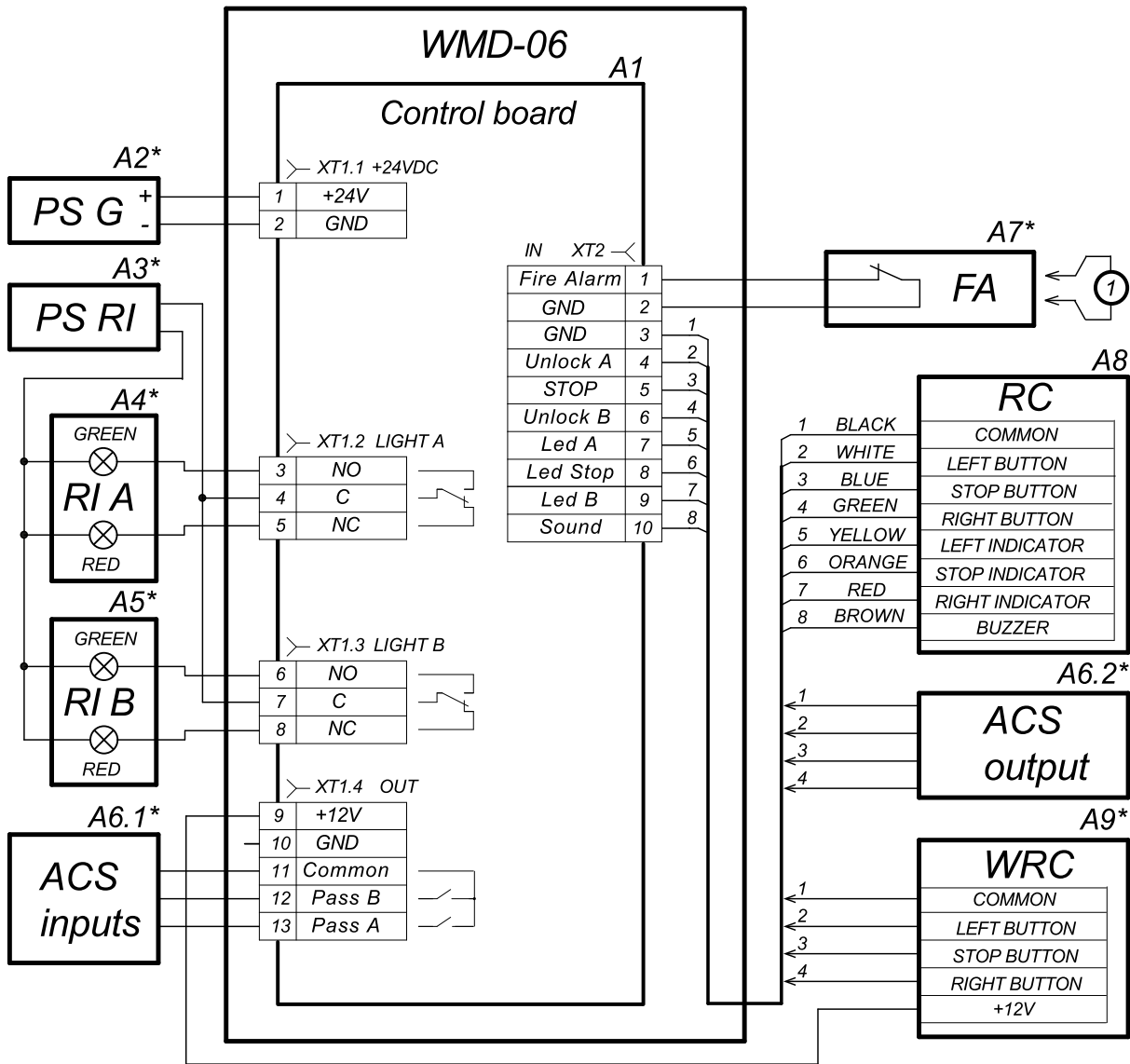

1 - jumper wire, installed when there is no FA device

Layout description	
Item	Description
A1	WMD-06 board
A2*	Power supply for the gate
A3*	Power supply for remote indicators
A4*, A5*	Remote indicator
A6*	Access control system
A7*	Device that gives an emergency unlocking command
A8	H-06/4.100 RC-panel
A9*	WRC

* The equipment is not included in the standard delivery set



WMD-06 Motorized gate

Operation algorithm

The swing gate can operate from the RC-panel (included in the delivery set), WRC, or ACS controller. Gate supports two control modes – pulse and potential. The Control mode is set by the jumper in the control board of the swing gate.

Pulse control mode is when a low-level input signal is sent or Unlock A, Stop and Unlock B contacts close with GND contact on the control board. Meanwhile, the duration of the control signal should not be less than 100 ms.

After applying a control signal at Unlock A (B), the swing gate will open in the selected direction and remain open for a period of time, called passage waiting time (4 seconds). When the passage waiting time expires, the motor drive resets the swing panel to its home position, and the swing gate switches to the "Passage denial" mode. Passage waiting time starts when the swing panels move more than 85 degrees.

Sending pulse to the Stop input places the swing gate in the "Passage denial" mode moving the swing panel to the home position.

Simultaneous sending of pulses to Unlock A (B) and Stop inputs places the swing gate in the "Free passage" mode in the selected direction.

It is recommended to use pulse mode during operation from RC-panel or WRC.

The potential control mode is when operating modes are set by holding the signal at Unlock (B) input of the XT2 connector on the control board with regard to the selected direction.

When sending a signal, the swing gate opens and remains open for the whole signal sending period; once the signal is removed, the swing gate closes. When pressing and holding the STOP button on the RC-panel, the swing gate closes even if a signal is applied to the Unlock A (B) input of the X2 connector on the control board.

The potential mode is used when operating as a part of ACS.

When the emergency unlocking device opens the contacts 1, 2 of the XT2 terminal block (Fire Alarm) regardless of the set operating mode, the swing panels unlock and gate drive opens the swing gate in the direction selected by the user (J2 jumper).

When closing the contacts 1, 2 of the XT2 terminal block (Fire Alarm), the swing gate performs the same actions as when powering up and switches to the "Passage denial" mode.

Overall dimensions

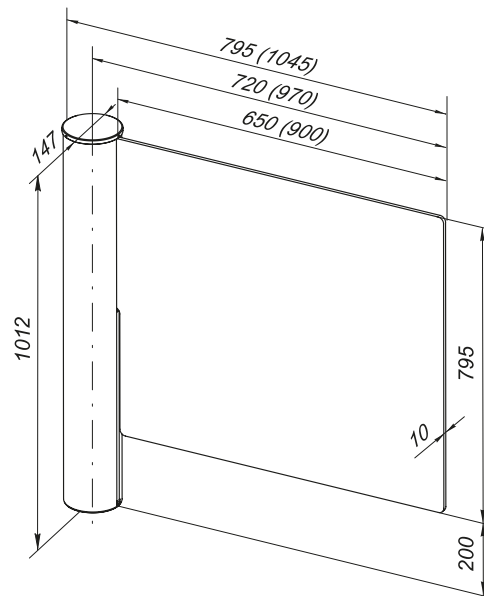

WMD-06 overall dimensions; dimensions are shown for 650 mm and 900 mm panels (in brackets)



Mounting

Foundation requirements: concrete (grade 400 or higher), stone or similar foundations of at least 150 mm thick. For the installation on a less steady foundation it is recommended to apply reinforcing elements (300×300×300 mm).

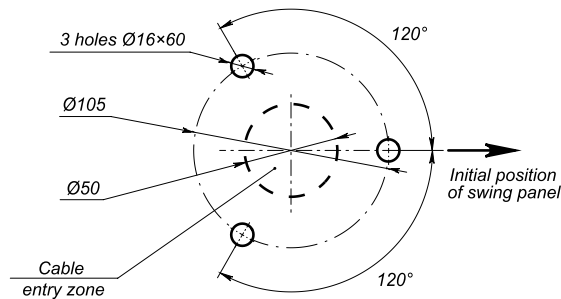

Hole marking for mounting the swing gate post

Passage zone modeling

When the swing gate is operated from ACS, it is recommended to place card readers in the turnstile housing or on the railings that form the passage zone. BH01 0-03 bracket is used for mounting readers on the BH02 series railings.

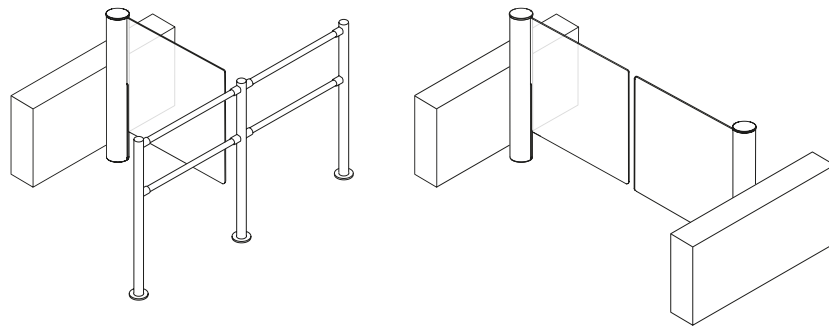

Example of an entrance zone project

Warranty

The warranty period is 5 (five) years commencing from the date of sale, unless otherwise determined in the delivery contract of the Product. In case of sale and installation of the equipment by authorized PERCo dealers and service centers, the warranty starts from the date of commissioning.

Should there be no date of sale on the warranty card, the warranty period shall commence from the date of manufacture specified in the Certificate and on the Product label.



WMD-05S Motorized gate



+55
+1
temperature range

24V
operating voltage

60W
power consumption

2
passage direction

12
persons/min

mechanical unlocking

motor drive

Application

The WMD-05S swing gate is a normally closed electromechanical waist-high gate designed for indoor operation.

The delivery set includes an RC-panel; the orientation of the RC-panel buttons relative to the directions of passage is set when connecting to the gate. It is recommended to install one gate based on a maximum working load of 12 persons/min. The gates can be equipped with matching railings.



RC-panel

Operating modes

Operating from the RC-panel, the gate supports three operating modes:

- passage denial
- single passage
- free passage

Main features

- operation from RC-panel, WRC, ACS
- motor drive integrated into the gate post swings by 90° in the set direction and resets smoothly to the home position after the passage
- built into the control unit reserve power supply
- Fire Alarm control input that allows connecting the emergency unlocking device (for example, fire alarm system)
- the gate can be powered both by 220V AC / 50Hz mains and by 24V DC external power supply
- two control modes – pulse and potential
- integrated mechanical release lock
- siren and intrusion detector can be connected to the gate



Mechanical unlocking with a key



Design

Gate post – polished stainless steel.

Gate panel – stainless steel, filler – plastic panel with pictograms.

Gate panel	Description
AG-650	650 mm swing panel
AG-900	900 mm swing panel
AG-1100	1100 mm swing panel

Operating conditions

Gate post, with regard to resistance to environmental exposure, complies to the following requirements: WMD-05S – GOST 15150 category U4 (operation in premises). WMD-05S gate should be operated at ambient air temperature from +1 °C to + 55 °C and at relative air humidity of up to 70% at +27 °C.

The remote control unit, with regard to resistance to environmental exposure, complies with GOST 15150 category NF4 (operation in premises with climate control). Control unit should be operated at ambient air temperature from +1 °C to + 40 °C and at relative air humidity of up to 80% at +25 °C.

It is a serially produced product certified for compliance with applicable Russian and European CE standards.

Delivery set

Gate post	1
Swing panel with fasteners kit, panel type (650, 900, 1100 mm) is chosen by the customer when ordering.	1
Filler panel	1
RC-panel (cable length of 6.6 m)	1
CU-05.1 control unit with two 7h-a / 12V batteries (network cable length of 1.5 m)	1
Mounting hardware for control unit	1
Key to mechanical release lock	2
Control cable (4 m*)	1
Power cable (4 m*)	1
Documentation set	1
Spare parts and accessories kit	1

Optional equipment (upon request)

WRC (consisting of a receiver and two transmitters in the form of key fobs) with a range of up to 40 m	1
Intrusion detector (installed upon request at the manufacturing site)	1
Siren (for signalling that an unauthorized passage has been attempted)	1
PFG IH10 anchor, M10x70A2 bolt with internal hex (SORMAT)	3

* The maximum allowed cable length (upon request) is 30 m.

Technical specifications

Powering by AC mains	Operating voltage	220±22 V, 50±1 Hz
	Power consumption	max. 60 W
Powering by external DC power supply	Admissible value of supply voltage	22 – 28 V
	Current consumption	MAX. 2.0 A
	Power consumption	max. 50 W
	Running time when powered by reserve power supply	min. 1.5 h
	Number of passages when powered by reserve power supply	min. 1200



WMD-05S Motorized gate

Passageway width	for 650 mm panel	700 mm
	for 900 mm panel	950 mm
	for 1100 mm panel	1150 mm
Gate overall dimensions (LxWxH)	with 650 mm panel	773x145x1012 mm
	with 900 mm panel	1023x145x1012 mm
	with 1100 mm panel	1223x145x1012 mm
gate post weight	max. 23.5 kg	
Control unit overall dimensions (LxWxH)	295x290x75,5 mm	
Control unit weight	max. 9.6 kg	
Package dimensions	Gate post with control unit	108x36x31 cm
	650 mm swing panel	84x38x7 cm
	900, 1100 mm swing panel	125x38x7 cm
Throughput rate	12 passages / min	
Mean time to failure	500,000 passages	

Connection

- Standalone operation – gate is operated from the RC-panel

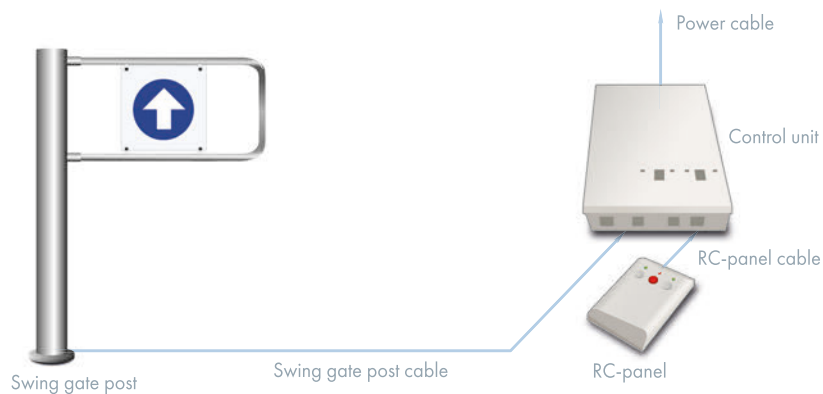

WMD-05S wiring diagram

RC-panel is connected through the cable entry zone of the control unit to the processor module. The buttons orientation relative to the gate can be changed by swapping the RC-panel wires connected to the X3.1 and X3.3, and also X4.1 processor module contacts (see the wiring diagram).

When pressing the left or right button, the gate opens in the corresponding direction. The gate will automatically close either in 5 seconds or upon pressing the STOP button (the middle button).

When the "Passage waiting time" jumper of the processor module is removed, a 5-second countdown is not applied and the gates close only upon pressing the STOP button. The jumper is installed by default.

Turnstiles, gates and railings

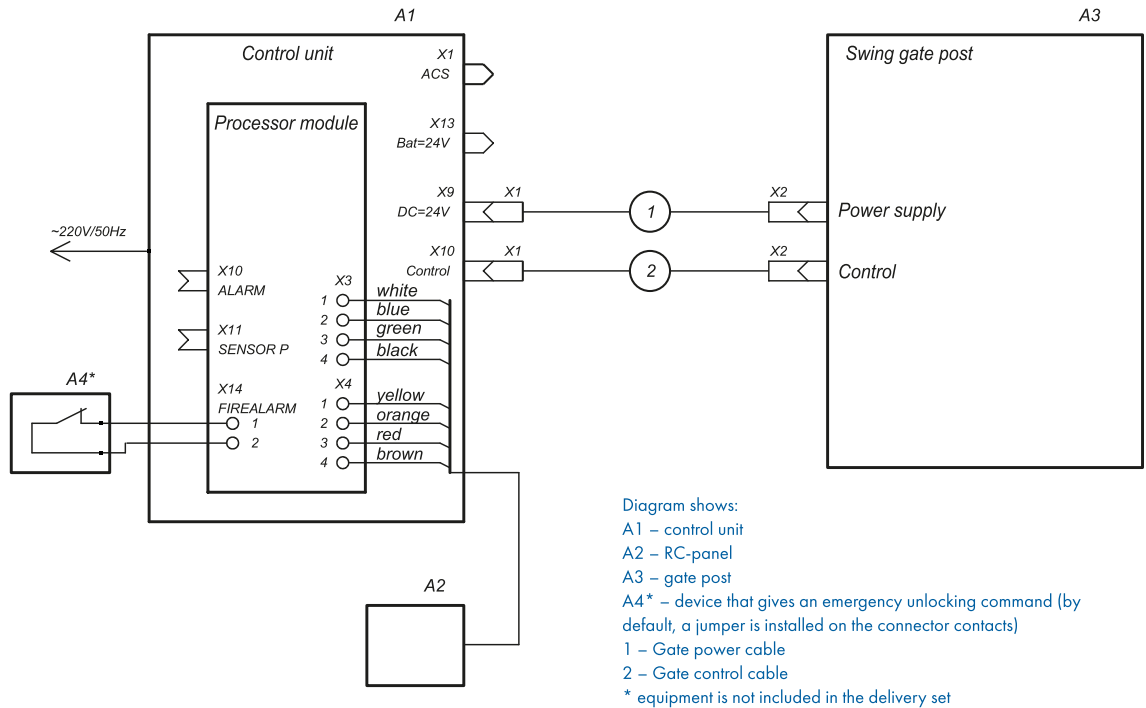

WMD-05S wiring diagram

- Operation of the gate as a part of ACS – control lines are connected to the "ACS" connector of the control unit (mating connector is included in the delivery set)

Control unit "ACS" connector contacts description			
Connector	Contact	Electrical circuit	Designation
"ACS"	1	RIGHT	Control of the direction R
	2	STOP	Locking both directions
	3	LEFT	Control of the direction L
	5	GND	Common
	7	PASS R1	Passage signal in direction R (relay contacts open when a passage in direction R takes place).
	10	PASS R2	
	6	PASS L1	Passage signal in direction L (relay contacts open when a passage in direction L takes place).
	9	PASS L2	
	8	Pwr failure C	Mains supply failure
	4	Pwr failure E	
	11	Pass Sensor1	Intrusion detector status, if installed (relay contacts)
	14	Pass Sensor2	
	12	Bat failure C	Reserve power supply failure
13	Bat failure E		

Operation algorithm

Gate supports two control modes – pulse and potential. The mode is set by applying the wire jumper on the control unit processor module.

Pulse control mode.

The operation is performed by closing RIGHT, STOP, LEFT contacts with GND contact, or by sending a low-level signal. A normally open relay contact or a circuit with open collector output (duration of the control signal is min, 100 ms) can be the control element of the ACS.

After applying a control signal to RIGHT or LEFT lines, the gate remains open in the selected direction and will remain open until one of the events (which happens earlier):

- low-level signal at the STOP line



WMD-05S Motorized gate

- after 5 sec. expiration. (when the "Passage waiting time" jumper located on the processor module is removed, unlocking time control is not performed)

Pulse mode is recommended during operation from the RC-panel.

Potential control mode is when the control signal is applied to the RIGHT or LEFT input, the gate opens in the selected direction remains open during the entire holding signal time; STOP input is not active in this mode.

Potential mode is recommended during operation from the ACS controller.

Regardless of the selected control mode, PASS R or PASS L signals are generated when moving the gate in one direction or the other. The length of generated signals depends on the period of time the gate remains open for.

Cable for connecting the emergency unlocking device is led to the processor module through the ALARM cable entry zone of the control unit and is connected to the corresponding processor module contacts (see the wiring diagram).

Note

When operating the gate from the ACS controller, it is recommended to connect the RC-panel to the ACS controller.

Example of connection to the ACS

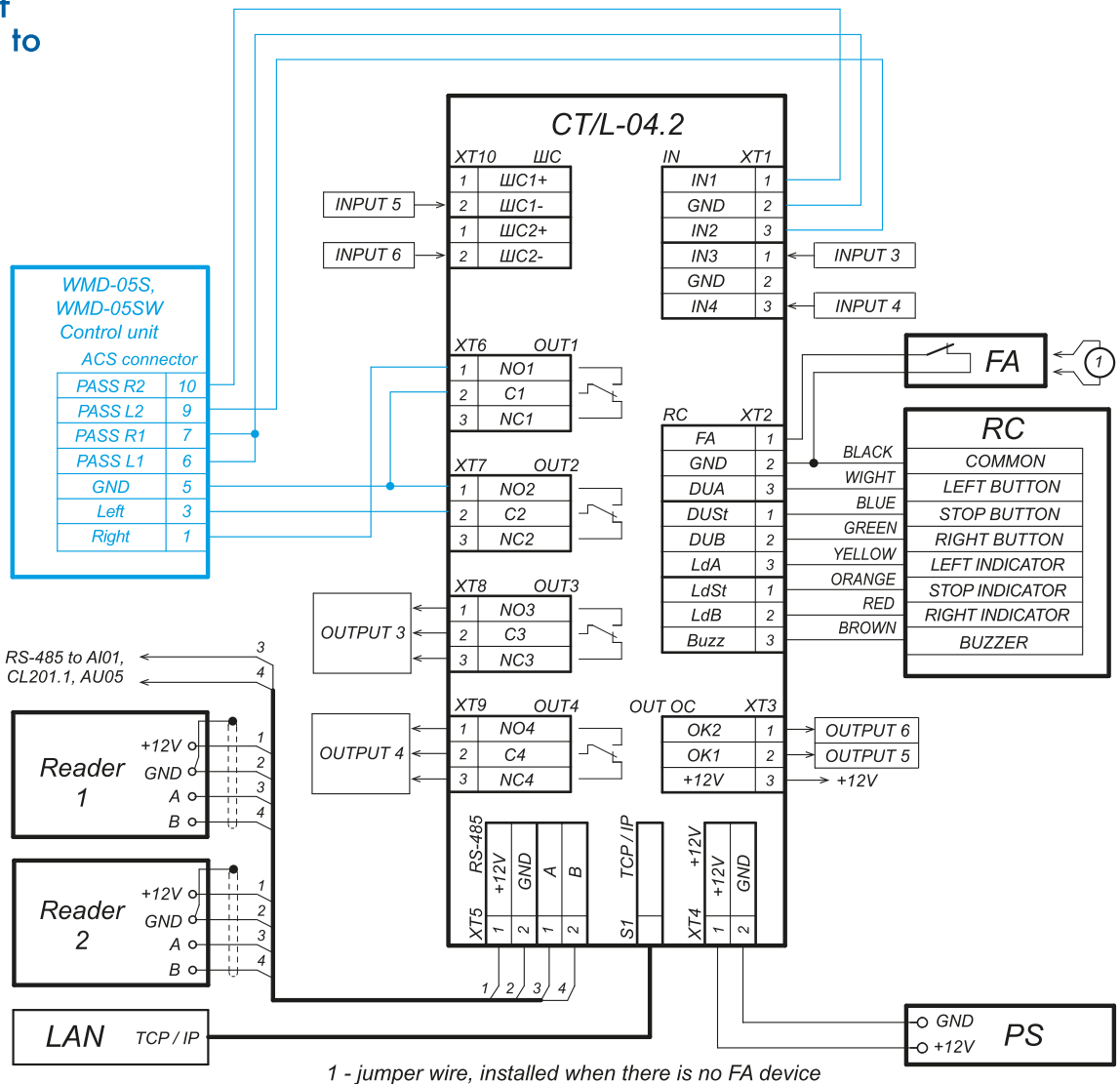

Example of gate connection to the ACS controller (using CT/L04.2 controller as an example)

Turnstiles, gates and railings



The maximum allowed cable length from the RC-panel / WRC / ACS controller to the control unit is 30 meters.

The maximum allowed power and control cable length from the control unit to the gate post is 30 meters.

Overall dimensions

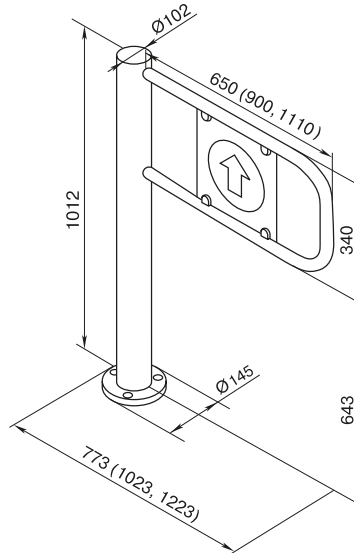

Overall dimensions

Mounting

Foundation requirements: concrete (grade 400 or higher), stone or similar foundations of at least 150 mm thick; when installing on a less steady foundation, use reinforcement element (450x450x200 mm).

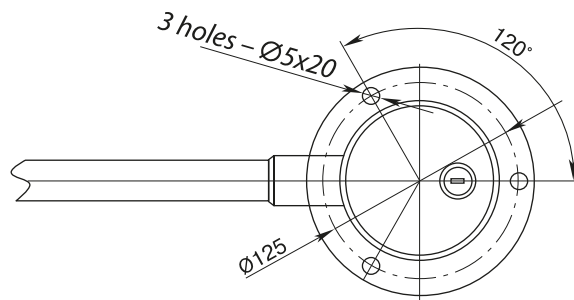

Hole marking for the gate



WMD-05S Motorized gate

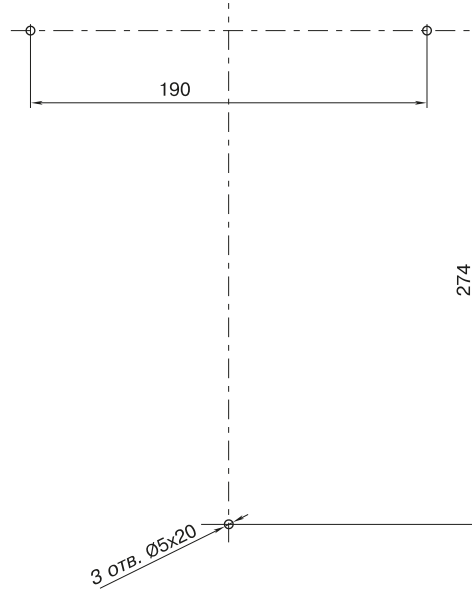

Example of an entrance project

Passage zone modeling

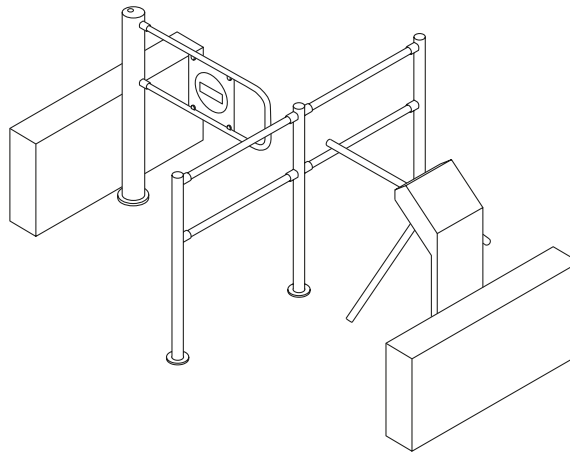

Example of an entrance zone project

Warranty

The warranty period is 5 (five) years commencing from the date of sale, unless otherwise determined in the delivery contract of the Product. In case of sale and installation of the equipment by authorized PERCo dealers and service centers, the warranty starts from the date of commissioning.

Should there be no date of sale on the warranty card, the warranty period shall commence from the date of manufacture specified in the Certificate and on the Product label.

WHD-05 Electromechanical gate

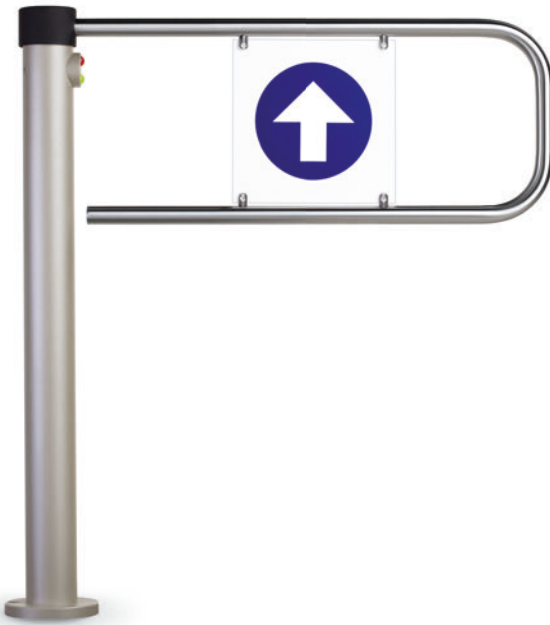

+50
+1
temperature range

20
persons/min

12V
operating voltage

2
passage direction

Application

WHD-05 gate is a normally opened electromechanical gate designed for indoor operation.

The delivery set includes an RC-panel; the orientation of the RC-panel buttons relative to the directions of passage is set when connecting to the gate. It is recommended to install one gate based on a maximum working load of 12 persons/min. The gates can be equipped with matching railings.



RC-panel

Operating modes

Operating from the RC-panel, the gate supports three operating modes:

- passage denial
- single passage in any direction
- free passage in any direction

When the gate is de-energized, the free passage mode is provided.

Main features

- operation from RC-panel, WRC, ACS
- built-in LED indication block of "Open/Closed" gate status
- one of the directions can be locked by using a mechanical limiter included in the standard delivery set
- hydraulic damper provides a smooth reset of the panel wing to the home position
- siren and intrusion detector can be connected to the gate
- Fire Alarm control input that allows connecting the emergency unlocking device (for example, fire alarm system)



LED indication



WHD-05 Electromechanical gate

Design

Gate post is made of powder-coated steel. Possible post finishes:



Light beige with pearl mica effect



dark grey with pearl mica effect

Panel	Post design
WHD-05R	Sandpaper powder coating with pearl mica effect; light beige colour
WHD-05G	Sandpaper powder coating with pearl mica effect; dark grey colour

Powder coating to RAL colours is available on order. The panel is made of polished stainless steel. Filler – reinforced plastic, passage grant / denial pictograms are serigraphy made.

Panel	Description
ASG-650	650 mm swing panel
ASG-900	900 mm swing panel

Operating conditions

Gate post, with regard to resistance to environmental exposure, complies with GOST 15150-69 category O4 (operation in premises with climate control). The operation of the gate is allowed at Ambient temperature from +1 °C to +50 °C and relative air humidity up to 98% at + 25 °C.

It is a serially produced product certified for compliance with applicable Russian and European CE standards.

Delivery set

Gate post	1
Swing panel with filler and fasteners kit, panel type (650 or 900 mm) is chosen by the customer when ordering.	1
RC-panel (cable length of 6,6 m)	1
Documentation set	1
Spare parts and accessories kit	1
Optional equipment (upon request)	
WRC (consisting of a receiver and two transmitters in the form of key fobs) with a range of up to 40 m	1
Intrusion detector (installed upon request at the manufacturing site)	1
Siren (for signalling that an unauthorized passage has been attempted)	1
PFG IH10 anchor, M10x70A2 bolt with internal hex (SORMAT)	3



Technical specifications

Operating voltage	10.8 – 13.2 V	
Current consumption	max. 1.2 A	
Power consumption	max. 14 W	
Passageway width	for 650 mm panel	700 mm
	for 900 mm panel	950 mm
Throughput rate in the single passage mode	with 650 mm panel	22 passages / min
	with 900 mm panel	20 passages / min
Mean time to failure	1,500,000 passages	
Daily average throughput rate in the single passage mode	3000 passages	
Overall dimensions (LxWxH)	with 650 mm panel	1040x780x160 mm
	with 900 mm panel	1040x1030x160 mm
Package dimensions (LxWxH)	Gate post	110x22x23 cm
	Gate post with filler	97x39x7 cm

Connection

For easy connection the electronics is divided into control and switching modules. The control module is securely fastened inside the post. The switching module is fastened on the removable bracket inside the bottom part of the post. All external connections are made to the switching module contacts.

Gate switching module terminal block contacts description			
Connector	Contact	Electrical circuit	Designation
XT1	1	+12 V	+12 V of the external power supply
	2	GND	Common
XT2L	1	+12VOut	Intrusion detector input
	2	Detector	
	3	GND	
	4	FA	Fire Alarm device input
	5	GND	
	6	GND	Common
	7	Unlock A	Gate control inputs
	8	Stop	
	9	Unlock B	
	10	Led A	
	11	Led Stop	RC-panel indication outputs
	12	Led B	
	13	ZUM	
XT2H	1	GND	Common
	2	+12VOut	
	3	Alarm 1	Siren
	4	Alarm 2	
	5	Com	PASS A relay output
	6	Pass A	
	7	Pass B	PASS B relay output
	8	Com	
	9	Def Out	Intrusion detector status output
	10	Imp/Pot	"Pulse mode/Potential mode" jumper
	11	GND	



WHD-05 Electromechanical gate

Turnstiles, gates and railings

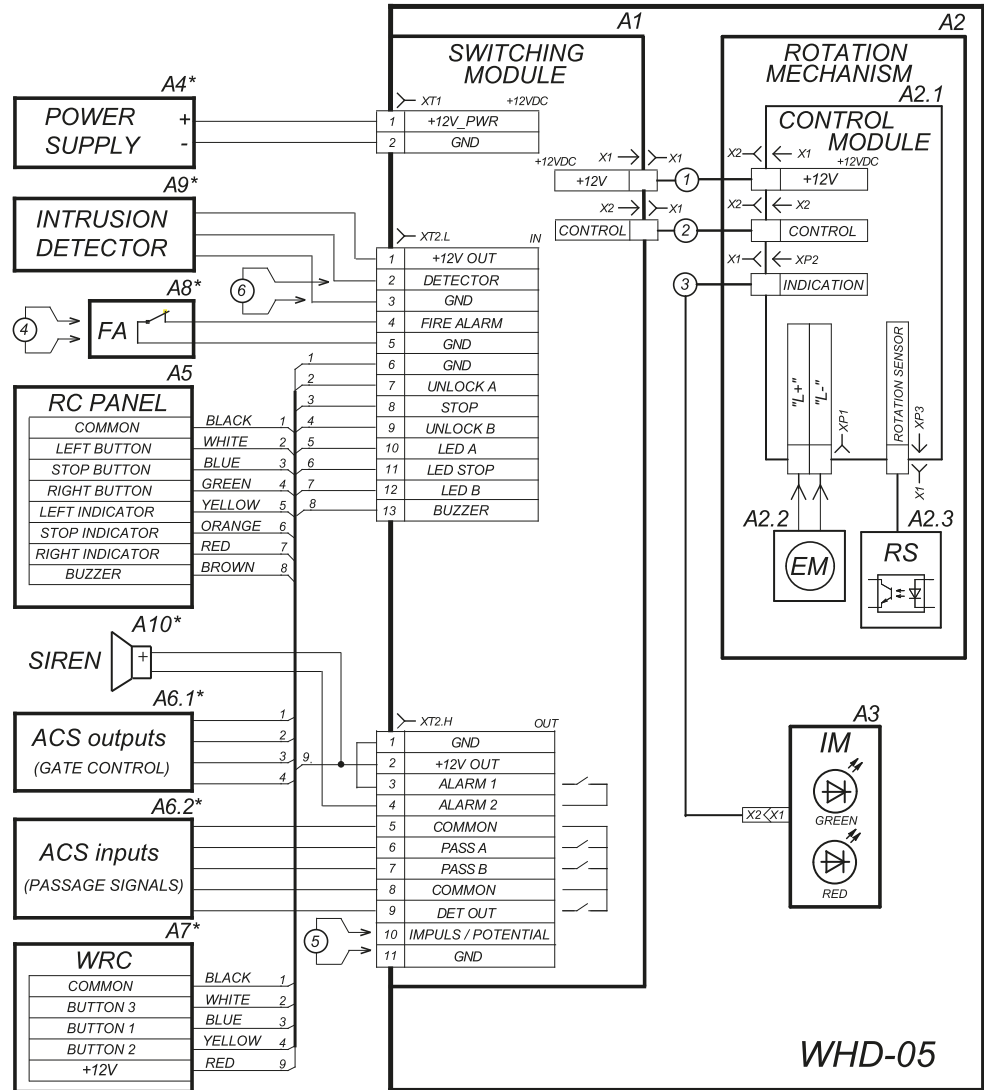

WHD-05 wiring diagram

Layout description	
Item	Description
A1	Switching module
A2	Rotation mechanism
A2.1	Control module
A2.2	Electromagnet assembly
A2.3	Rotation sensor
A3	Indication module
A4*	Power supply
A5	RC-panel
A6*	ACS controller
A7*	WRC
A8*	Device that gives an emergency unlocking command (Fire Alarm)
A9*	Intrusion detector
A10*	12V DC siren
1	Patch cable for control module power supply
2	Patch cable for control module control
3	Indication cable
4**	Jumper wire if there is no FA device (A8)
5**	Imp/Pot jumper wire for selecting the gate operating mode
6**	Jumper wire if there is no intrusion detector (A9)

* The equipment is not included in the standard delivery set

** Jumper wires installed by default

Operation algorithm

The gate can operate from the RC-panel (included in the delivery set), WRC, ACS controller and intrusion detector.

Operation is performed by applying a low-level signal to Unlock A, Stop and Unlock B contacts relative to the GND contact. The response to these signals depends on the control mode selected by the 5 jumper wire.

Pulse control mode is when a pulse is applied to the Unlock A (B) input, the gate will automatically open for a single passage in any direction. The waiting time for the passage being completed does not depend on the duration of the control pulse and lasts 5 seconds.

Sending a pulse to the Stop input locks both passage directions. Simultaneous sending of pulses to Unlock A (B) and Stop inputs places the gate in the "Free passage" mode.

It is recommended to use pulse mode during operation from RC-panel or WRC.

Potential control mode is when the control signal is applied to the Unlock A (B) input, the gate remains unlocked in any direction during the entire holding signal time. Sending control signal to the Stop input locks both passage directions regardless of the signals at the Unlock A (B) inputs. The potential mode is recommended during operation from the ACS controller or intrusion detector.

Regardless of the selected control mode, PASS A or PASS B signals are generated when moving the gate in one direction or the other. These signals can inform the ACS controller of the fact of passage. Emergency passage opening is performed by removing a low-level signal from the Fire Alarm contact relative to the GND contact.

Note:

When operating the gate from the ACS controller, it is recommended to connect the RC-panel to the ACS controller.

The maximum allowed cable length of the RC-panel (ACS controller) is 40 meters. Recommended cable type: CQR CABS8 8x0.22c.

The maximum allowed cable length of the power supply depends on its cross section and must be:

- 0.2 mm² cable cross-section – 10 m
- 0.75 mm² cable cross-section – 25 m
- 1.5 mm² cable cross-section – 50 m

Recommended cable type: Power cable (2x0.75).



WHD-05 Electromechanical gate

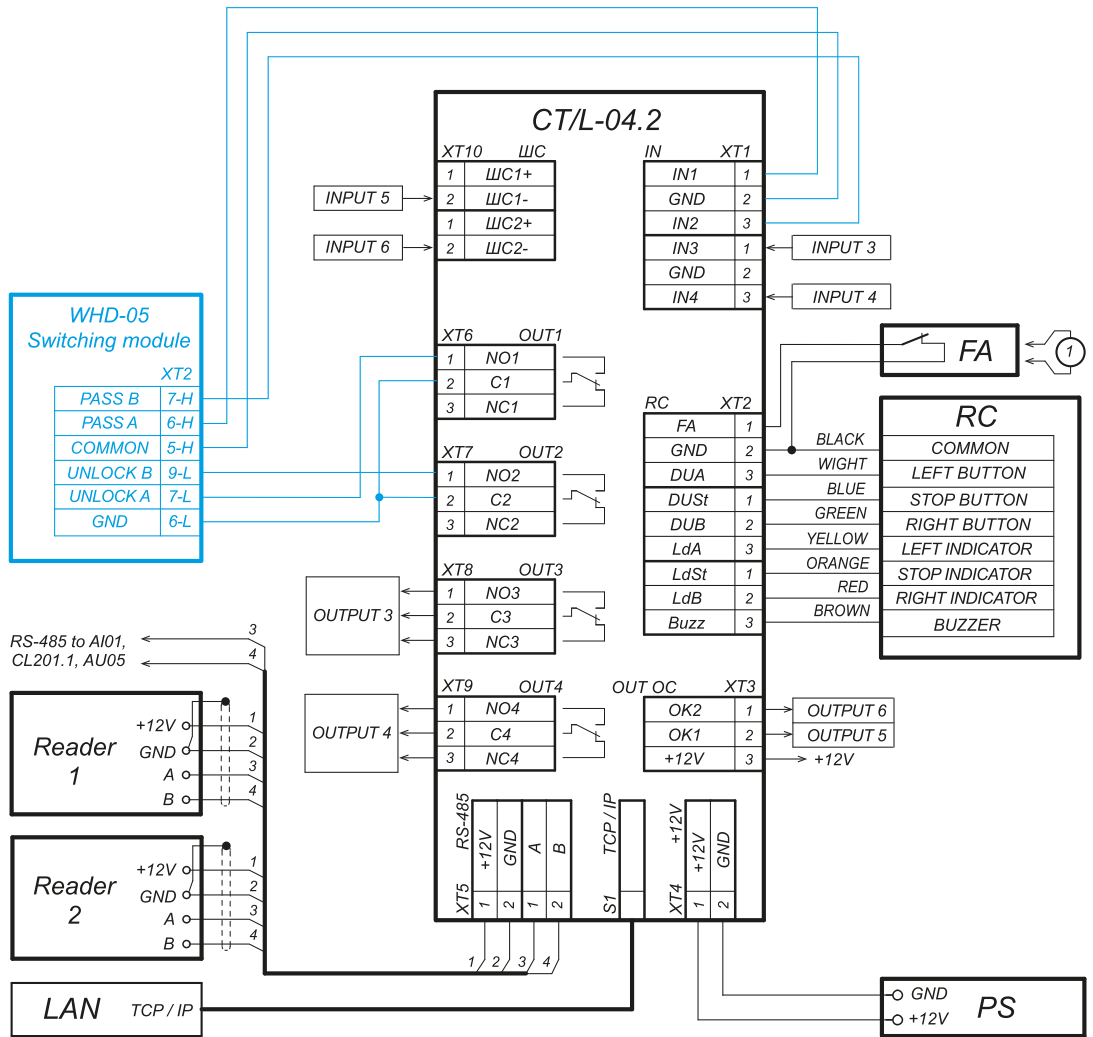

1 - jumper wire, installed when there is no FA device

Example of gate connection to the ACS controller

The maximum allowed cable length of the RC-panel / WRC / ACS controller is 30 meters.

Overall dimensions

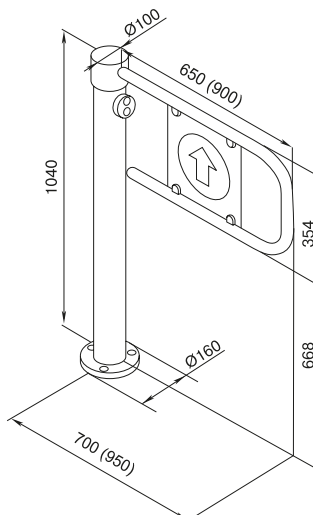

Overall dimensions

Turnstiles, gates and railings



Foundation requirements: concrete (grade 400 or higher), stone or similar foundations of at least 150 mm thick; when installing on a less steady foundation, use reinforcement element (450x450x200 mm).

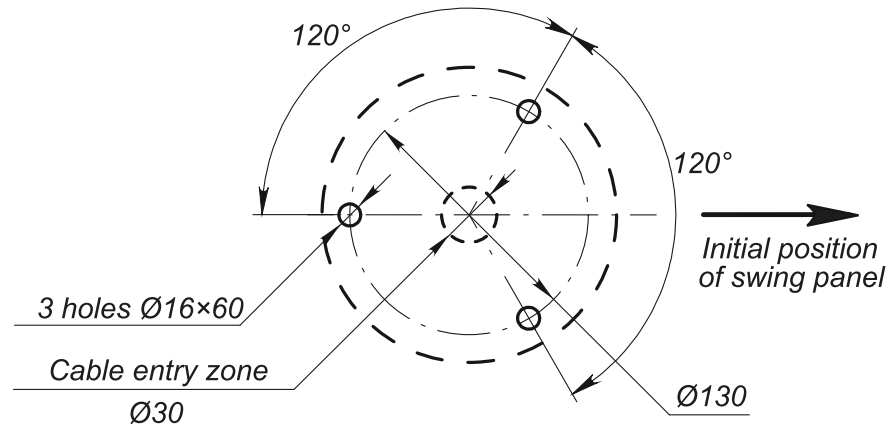

Hole marking

Before installing the gate, prepare the cable channel from the post center to the control unit (gate control and power cables).

When the gate is operated from ACS, it is recommended to place card readers in the turnstile housing or on the railings that form the passage zone. BH01 0-03 bracket is used for mounting readers on the BH02 series railings.

Passage zone modeling

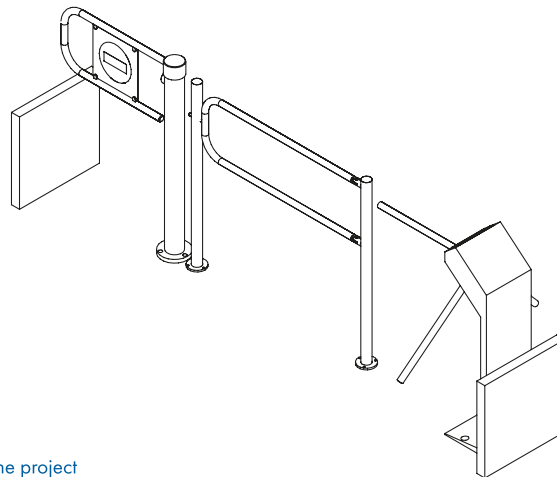

Example of an entrance zone project

Warranty

The warranty period is 5 (five) years commencing from the date of sale, unless otherwise determined in the delivery contract of the Product. In case of sale and installation of the equipment by authorized PERCo dealers and service centers, warranty starts from the date of commissioning.

Should there be no date of sale on the warranty card, the warranty period shall commence from the date of manufacture specified in the Certificate and on the Product label.



BH02 Waist-high railing systems

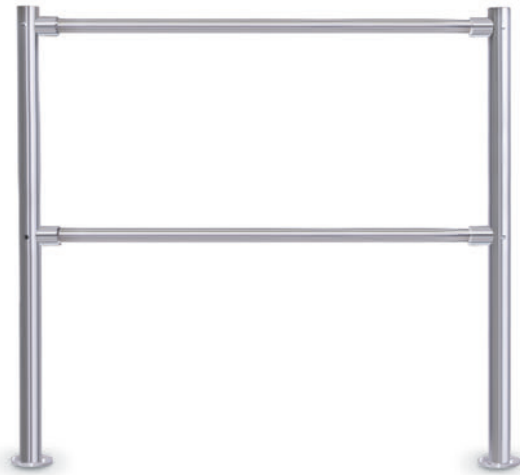

Application

BH02 waist-high railing sections are designed to arrange passage zones and decorate the entrance interiors of administrative buildings, industrial enterprises, retail outlets, banks, airports, railway stations. Railing sections are modular structure formed of posts and rails that are made of stainless steel in the same design as PERCo turnstiles and swing gates. The railing section of any configuration can be arranged by using different types of railings and its elements. Two main versions of railing systems are available:

- Fixed railing section with or without filler (see Fig.) designed for passage zone modeling and interior decoration. The filler can be made of tinted glass or polymer material
- Quick-release railing section with or without filler is designed for temporary passage zone modeling
- Rotary railing section is designed for passage zone modeling and for arranging emergency exit (see Fig.). There are three versions: a rotary section with a mechanical locking device, an automatic rotary section with an electromagnetic locking device, and a double-leaved railing section with a magnetic locking device



Fixed railing section with filler

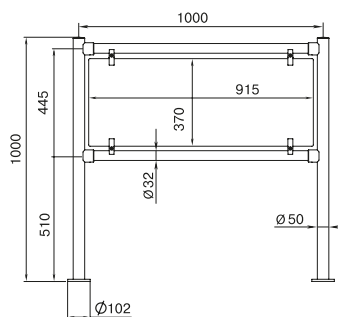

Fixed railing section without filler

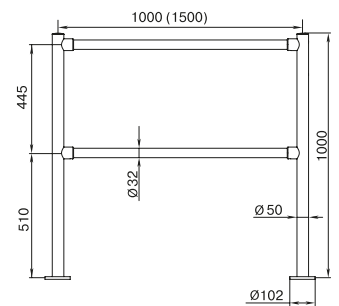

Choosing a corresponding vertical post provides straight-lined coupling of the railing sections and coupling at a 90° angle. BH02 O-01 adjustable coupling fitting is used to install railing sections at any angle (from 90° to 180°).



Coupling fittings

Turnstiles, gates and railings



Posts of the quick-release railing section are to be installed in two special flanges fixed to the mounting surface with anchors. Posts of the quick-release railing section are to be installed in two special flanges fixed to the mounting surface with anchors. It provides the possibility to remove rapidly the section and install it back with ease. A rotary railing section with a mechanical locking device is usually used for passage zone modeling. When the section is unlocked, the swing panel can be opened in any direction using a manual unlocking device without any tools and keys. The automatic rotary railing section can be unlocked by an electrical signal (sent from an emergency button, access control system, or a switch used for de-energizing the railing section). At a power loss, the section unlocks automatically. The swing panel can be opened in any direction. The anti-panic function is incorporated into the rotary sections with electromagnetic and magnetic locking device. Applying some force in pushing the section, the swing panel opens without any special tools and keys. After emergency passage opening the section does not get deformed and can be closed again.



Mounting flange for the quick-release railing section



Adjustable coupling fitting for the rotary sections



Double-leaved railing section

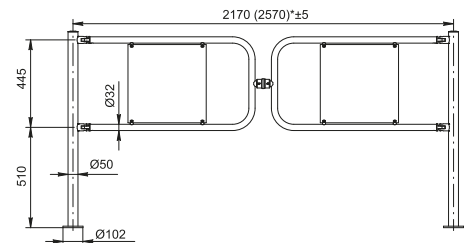

Mechanical rotary railing section

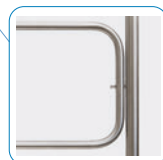

Unlocking device

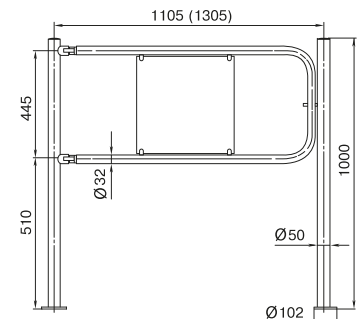

Automatic rotary railing section

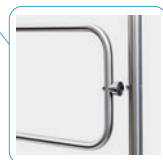
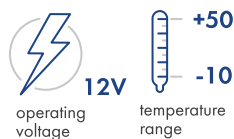

Electromagnetic locking device

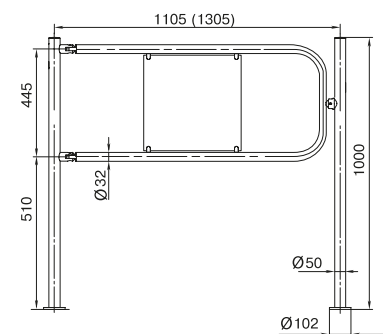



BH02 Waist-high railing systems

Design

Rotary sections are produced in two standard sizes: with 1000 and 1200 mm passageway width, for the double-leaved section – 2000 and 2400 mm respectively. The rotary section with 1200 mm-wide passageway meets the fire safety regulations regarding minimum emergency exit width.

Railing section posts and rails are made of stainless steel.

Section posts – Ø50 mm pipes, rails – Ø32 mm pipes. Filler – tinted glass or polycarbonate plastic. The range of elements for the BH02 waist-high railing section is stated in the tables below.

Vertical posts for BH02 railing section

Item	Designation (for railing sections without filler)
One-way post with 2 holes for mounting the coupling fittings	BH02 2-00
Two-way post with 4 holes for mounting the coupling fittings (angle between pairs of holes is 180°)	BH02 2-01
Two-way post with 4 holes for mounting the coupling fittings (angle between pairs of holes is 90°)	BH02 2-02
Three-way post with 6 holes for mounting the coupling fittings (angles between pairs of holes are 90° and 180°)	BH02 2-03
Posts for anti-panic rotary railing section with mechanical locking device	
Post with a hole for rotary section locking device	BH02 2-14
Post with a hole for rotary section locking device and with 2 holes for mounting the coupling fittings to the opposite swing panel	BH02 2-15
Three-way post with a hole for mounting the locking device of the rotary section and with 6 holes for mounting the coupling fittings (angles between pairs of holes are 90° and 180°)	BH02 2-16
Posts for anti-panic rotary railing section with electromagnetic locking device	
Post with electromagnetic locking device	BH02 2-04/EL
Post with electromagnetic locking device and with 2 holes for mounting the coupling fittings to the opposite swing panel	BH02 2-05/EL
Three-way post with electromagnetic locking device and with 6 holes for mounting the coupling fittings (angles between pairs of holes are 90° and 180°)	BH02 2-06/EL

Coupling fittings, rails and swing panels for the BH02 railing section

Description	Item
Standard coupling fittings with fasteners	BH02 0-10
Adjustable coupling fittings with fasteners and hinged panel	BH02 0-11
925 mm rail	BH02 1-00
1425 mm rail	BH02 1-01
Hinged panel (with locking device) for mechanical rotary section with pictogram filler; passageway width is 1000 mm	BH02 1-14
Hinged panel (with locking device) for mechanical rotary section with pictogram filler; passageway width is 1200 mm	BH02 1-15
Hinged panel for automatic rotary section with pictogram filler; passageway width is 1000 mm	BH02 1-06/EL
Hinged panel for automatic rotary section with pictogram filler; passageway width is 1200 mm	BH02 1-07/EL



Optional equipment for BH02 railing section

Description	Item
Reader bracket with mounting kit	BH02 0-03
Filling glass for the 1.0 m-long BH02 railing section	
Polymer filler for the 1.0 m-long BH02 railing section	
Clips	BH02 0-02

Operating conditions

Railings, with regard to resistance to environmental exposure, comply with GOST 15150-69 category NF3.1 (operation in premises without climate control). Operation is allowed at ambient temperature from +10°C to +50°C and relative air humidity up to 75% at + 15°C.

Delivery set

Railing section elements	as per order
Operation Manual	1 set
Certificate for the post with electromagnetic locking device (BH02 2-04/EL, BH02 2-05/EL, BH02 2-06/EL)	1
Power supply (1A PS unit) for post with electromagnetic locking device	
SORMAT PFG IH 10 anchor bolt for mounting vertical posts to the floor	3 per 1 post

Mounting

Foundation requirements: concrete (grade 400 or higher), stone or similar foundations of at least 150 mm thick. For the installation on a less steady foundation it is recommended to apply reinforcing elements (300×300×300 mm).

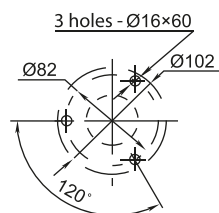

Hole marking

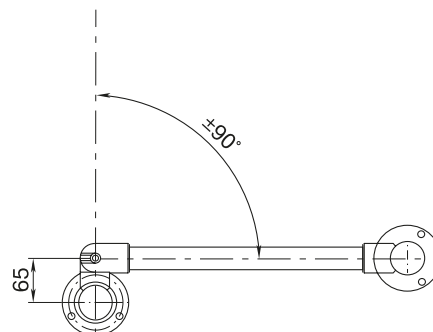

Layout of possible rotation angles of the BH02 adjustable coupling fitting

Warranty

The warranty period of the post with the electromagnetic locking device of the rotary railing section (BH02 2-04/EL, BH02 2-05/EL, BH02 2-06/EL) is 5 (five) years commencing from the date of sale unless otherwise determined in the delivery contract of the Product. In case of sale and installation of the equipment by authorized PERCo dealers and service centers, the warranty starts from the date of commissioning. Should there be no date of sale on the warranty card, the warranty period shall commence from the date of manufacture specified in the Certificate and on the Product label



BH02 Waist-high railing systems

Railings assembly examples

Example 1.

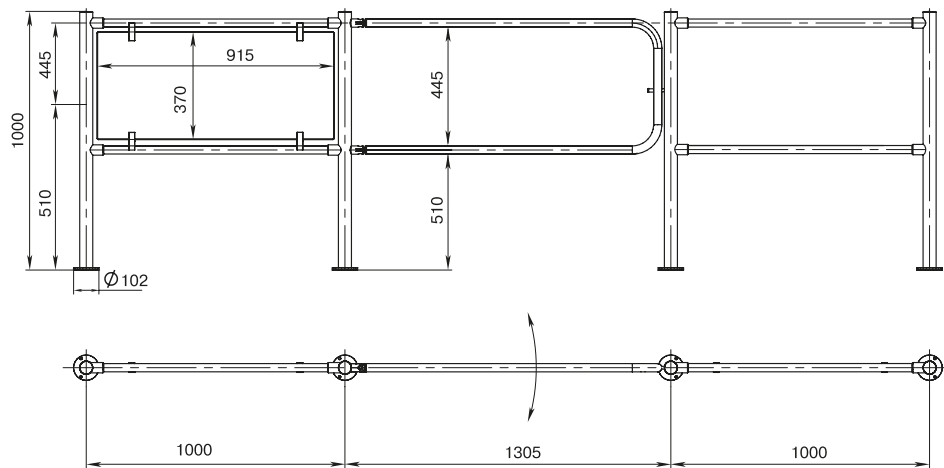
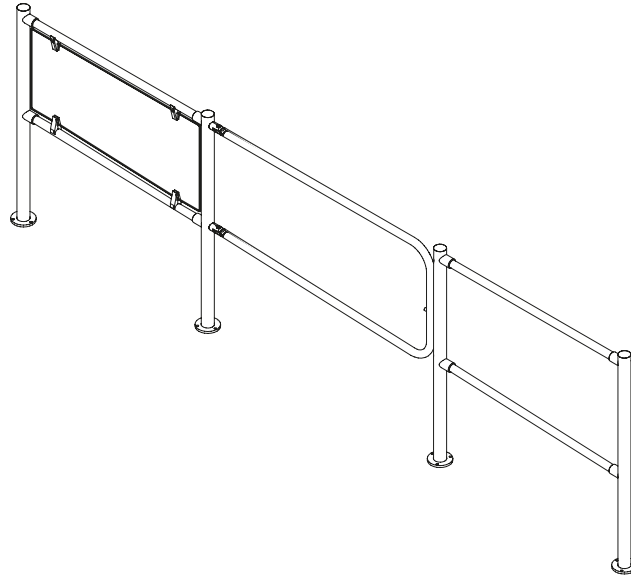

BH02 2-00	One-way post with 2 holes for mounting the coupling fittings	2
BH02 2-01	Two-way post with 4 holes for mounting the coupling fittings (angle between pairs of holes is 180°)	1
BH02 2-15	Post with a hole for rotary section locking device and with 2 holes for mounting the coupling fittings to the opposite swing panel	1
BH02 1-00	925 mm rail	4
BH02 1-17	Hinged panel (with locking device) for mechanical rotary section with pictogram filler; passageway width is 1200 mm	1
BH02 0-10	Standard coupling fittings with fasteners	8
	370x915 mm tinted filling glass for the 1.0 m-long BH02 railing section	1
BH02 0-02	Clip	4



Example 2.

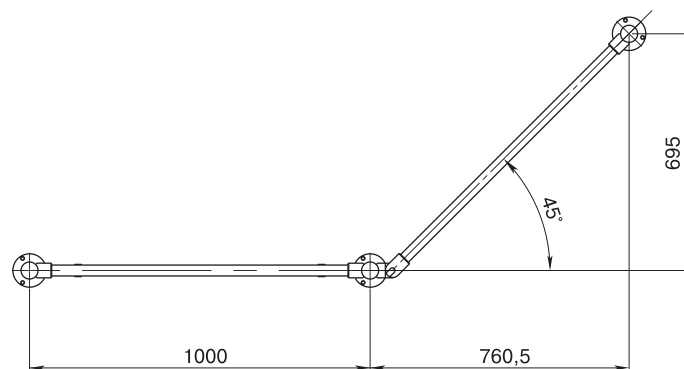
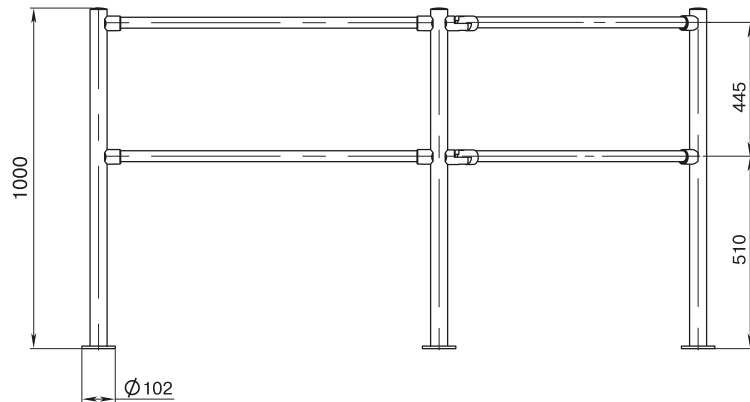
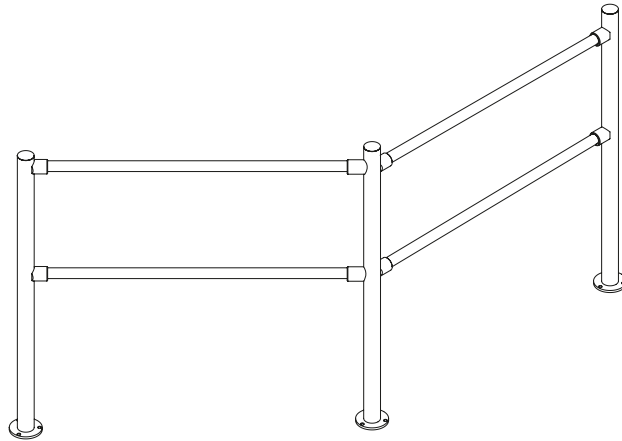

BH02 2-00	One-way post with 2 holes for mounting the coupling fittings (for railing sections without filler)	2
BH02 2-01	Two-way post with 4 holes for mounting the coupling fittings (angle between pairs of holes is 180°, for railing sections without filler)	1
BH02 1-00	915 mm rail	4
BH02 0-10	Standard coupling fittings with fasteners	6
BH02 0-11	Adjustable coupling fittings with fasteners and hinged panel	2



BH02 Waist-high railing systems

Example 3.

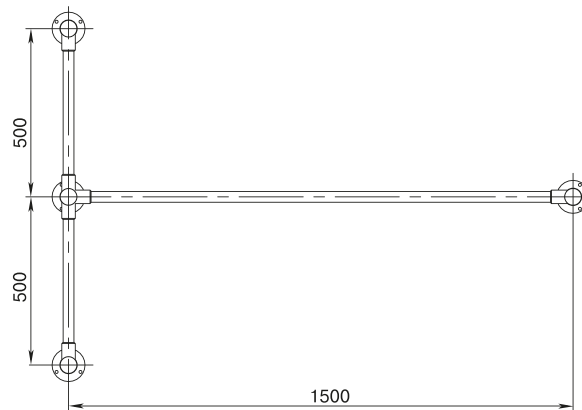
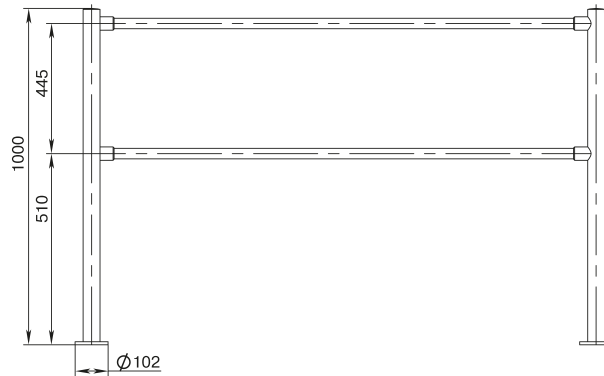
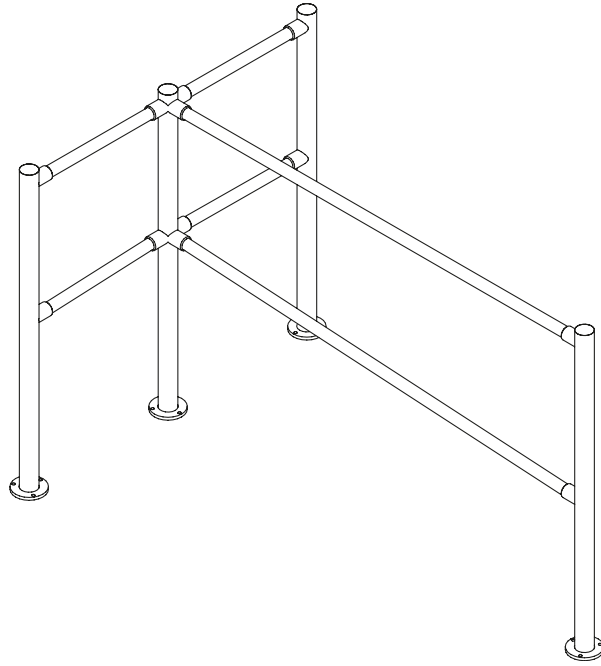

BH02 2-00	One-way post with 2 holes for mounting the coupling fittings (for railing sections without filler)	3
BH02 2-03	Three-way post with 6 holes for mounting the coupling fittings (angles between pairs of holes are 90° and for railing sections without filler)	1
BH02 1-00	925 mm rail	2
BH02 1-11	1415 mm rail	2
BH02 0-10	Standard coupling fittings with fasteners	12



Passage zone modeling

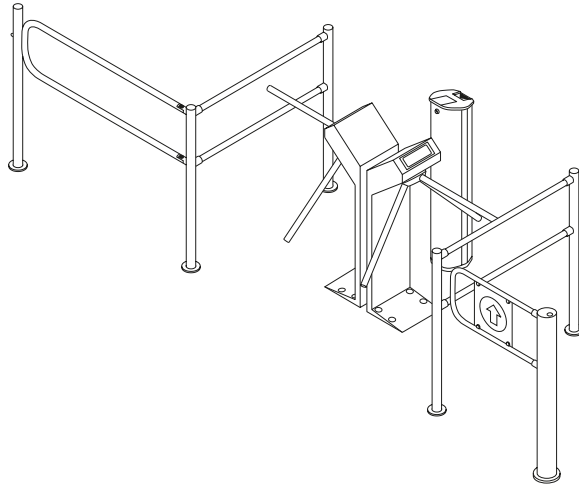

Tripod turnstiles with standard and rotary railing sections, card capture reader, swing gate

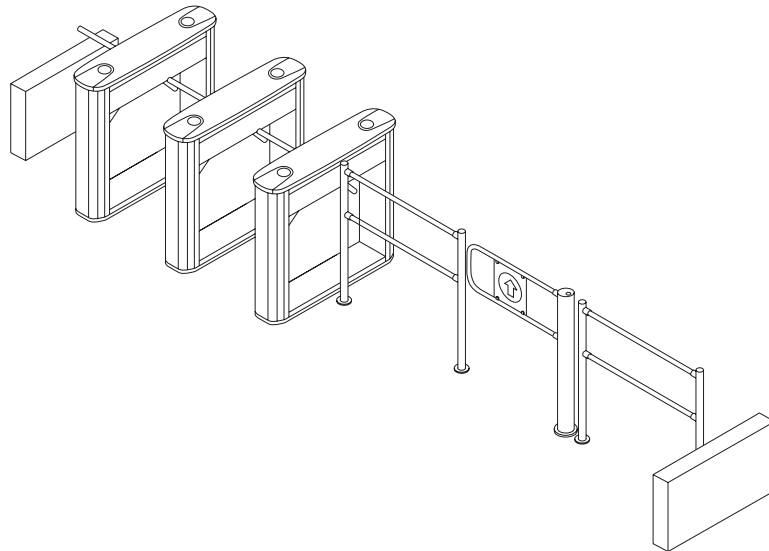

Box tripod turnstiles with standard railing sections, swing gate

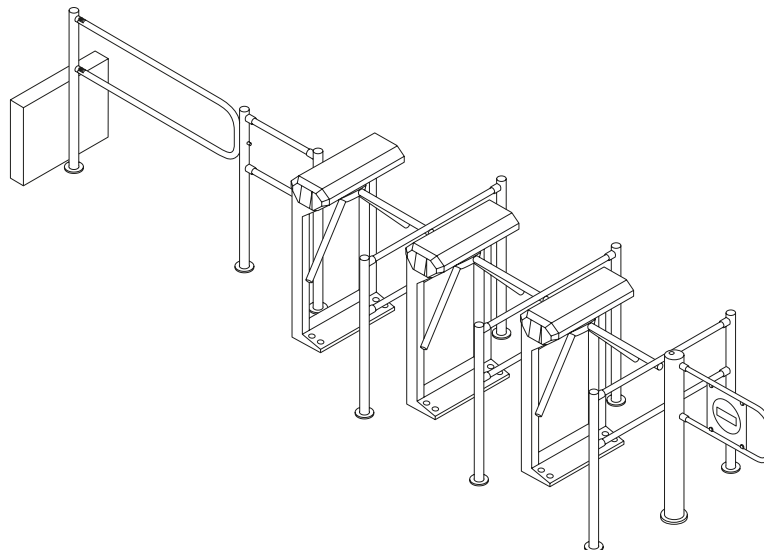

IP-Style with standard and rotary railing sections, swing gate



BH02 Waist-high railing systems

Turnstiles, gates and railings

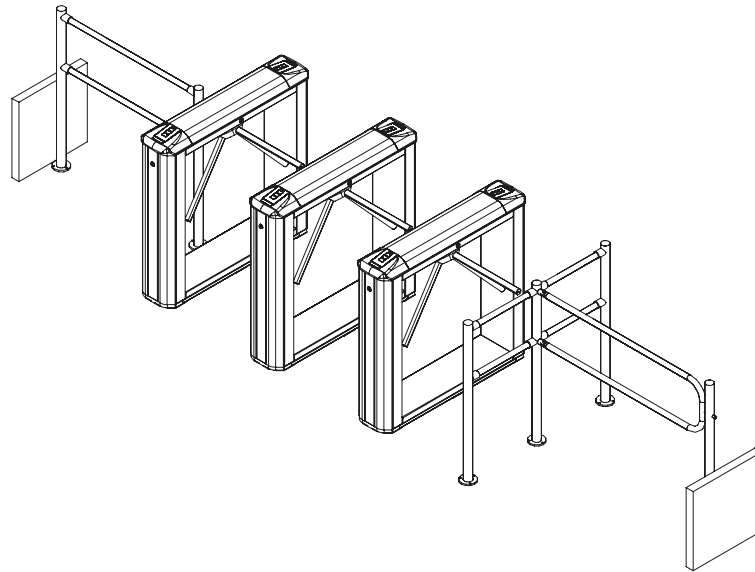

Box tripod turnstiles with built-in readers, standard and rotary railing sections

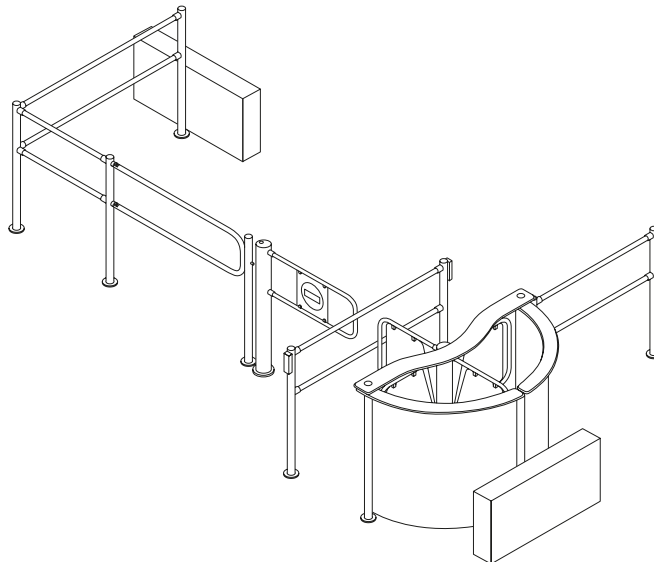

Rotor turnstile with standard and rotary railing sections, swing gate

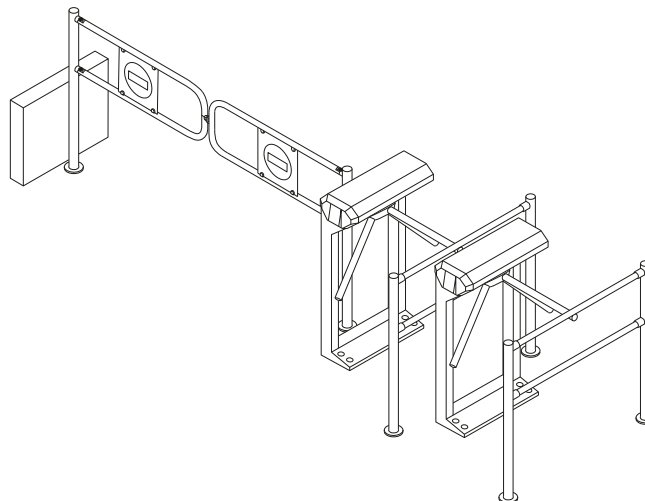

IP-Style with rotary railing section

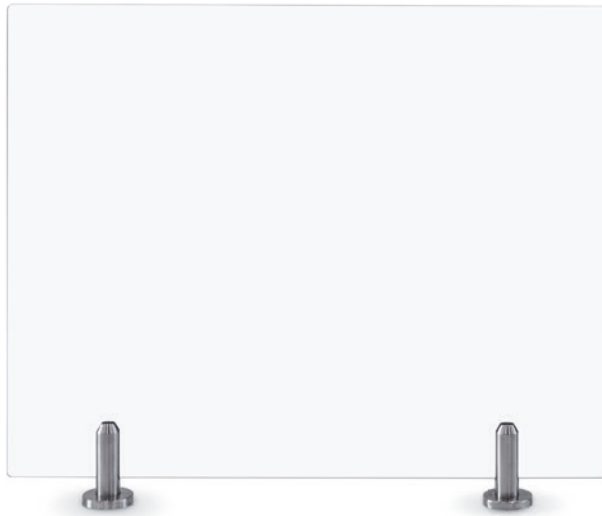

Application

BH06 waist-high railing section is designed to arrange passage zones and decorate the entrance interiors of administrative buildings, industrial enterprises, retail outlets, banks, airports, railway stations.

Railing system is a modular structure formed of sections. Each section consists of two or three BH06 2-00 stainless steel mini-posts with a 10 mm sheet of tempered glass. Railing section of any configuration can be arranged by using different types of railings and its elements.

Mini-post is a tubular post that is fixed on the flange and features a groove for the glass sheet. The flange is fixed with 4 anchors on the mounting surface and is covered with a decorative plate. The glass is fixed in the post groove by means of hold-down plate with a rubber gasket and two fixing bolts.



BH06 2-00 mini-post

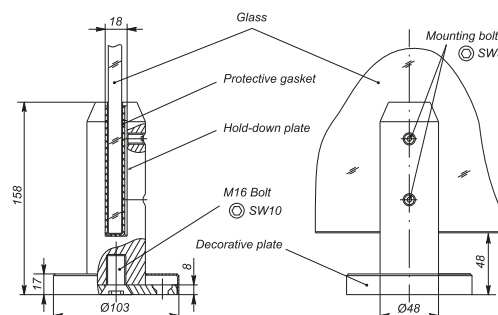

Railing sections are available in two standard sizes: 1000 mm-wide or 1500 mm-wide, 1000 mm-high.

It is possible to order a section of different size not exceeding 1500 mm.



BH06 Waist-high railing systems

Design

10 mm tempered sheet glass.

Operating conditions

Railings, with regard to resistance to environmental exposure, comply with GOST 15150-69 category NF3.1 (operation in premises without climate control). Operation is allowed at ambient temperature from +10°C to +50°C and relative air humidity up to 75% at + 15°C.

Delivery set

Railing sections (tempered sheet glass) - specified by the customer	as per order
BH06 2-00 mini-post	2 or 3 per one section
Operation Manual	1
Optional equipment (upon request)	
M10 anchor bolt (DIN 7984, stainless, internal hexagon) with SORMAT PFG IH 10 anchor for mounting vertical posts to the floor	4

Mounting

Foundation requirements: concrete (grade 400 or higher), stone or similar foundations of at least 150 mm thick. For the installation on a less steady foundation it is recommended to apply reinforcing elements (300×300×300 mm).

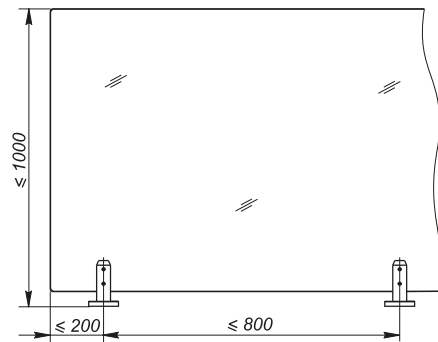

Installation recommendations

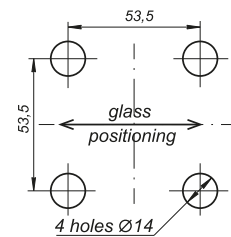

Hole marking for mini-post

RTD-15 Full height rotor turnstile



temperature range



operating voltage



power consumption



passage direction



persons/min



mechanical unlocking



motor drive

Application

RTD-15 full height rotor turnstile is a normally closed electromechanical turnstile designed for indoor and outdoor operation.

Two versions of the RTD-15 turnstile are available:

- RTD-15.1 – with motor drive. The motor drive is activated at the beginning of the passage through the turnstile once the rotor has turned about 12° and starts rotating in the passage direction till the home (closed) position reached
- RTD-15.2 – with mechanical drive. In this case during the passage through the turnstile after the rotor has been turned more than 60°, the actuating mechanism resets the rotor to its home (closed) position

The delivery set includes an RC-panel. The orientation of the buttons relative to the passage directions is to be set upon connecting the RC-panel to the turnstile. It is recommended to install one turnstile based on a maximum working load of 20 persons/min. Turnstiles can be equipped with a matching gate and railings.

The turnstile provides passage control in two directions, turnstile operating mode may be set independently for each passage direction.



RC-panel

Operating modes

Supported operating modes:

- passage denial in both directions
- single passage in one direction and passage denial in the other direction
- single passage in both directions
- free passage in one direction and passage denial in the other direction
- free passage in one direction and single passage in the other direction
- free passage in both directions
- lock-chamber mode (two-step mode with a pass-through verification, set during installation)



RTD-15 Full height rotor turnstile

Main features

- operation of the turnstile from RC-panel, WRC, ACS
- built into the turnstile housing electronic board
- lock-chamber mode is available
- reverse rotation locking – prevents reverse rotation of the rotor once the rotor has been turned more than 60°
- Fire Alarm control input that allows connecting the emergency unlocking device (for example, fire alarm system)
- Mechanical unlocking with a key is available for each passage direction which provides free rotation in this direction
- built-in hyperluminous LED indicators of the passage grant / denial
- built-in walkway downlights (two 4W LED lamps)
- matching canopy protects the turnstile from precipitations and climbing over
- turnstile can be installed on loose ground using a special mounting frame
- high corrosion resistance of the structure made of aluminium alloy provides a long service life in the adverse environmental conditions
- high-quality polymer powder coating provides outer appearance at continuous duty
- two control modes – pulse and potential
- possibility to connect an intrusion detector and a siren to the turnstile



Mechanical unlocking with a key



LED indicator

Operating conditions

The turnstile, with regard to resistance to environmental exposure, complies with GOST 15150-69 category N2 (operation outdoors). The operation of the turnstile is allowed at ambient temperature from -40°C to +55°C and relative air humidity up to 98% at + 25°C. Top channel protection class – IP53.

The RC-panel, with regard to resistance to environmental exposure, complies with GOST 15150-69 category NF4 (operation in premises with climate control). RC-panel should be operated at ambient air temperature from +1°C to + 55°C and at relative air humidity of up to 80% at +25°C.

Design

Housing – powder-coated aluminium structure. Housing colour – light beige with a pearl mica effect. Powder coating to RAL colours is available on order.

It is a serially produced product certified for compliance with applicable Russian and European CE standards.

Delivery set

Rotor section	3
Barrier section assembly with indication block and indication cable assembly	1
Guide barrier set assembly with indication block	2
Top channel	1
Mounting hardware required for turnstile installation	1
RC-panel (cable length of 6.6 m)	1
Key to mechanical release locks (2 per each lock)	4
Documentation set	1
Spare parts and accessories kit	1



Optional equipment (upon request)	
RF01 Foundation frame	1
RTC-15.3 Canopy	1
WHD-15 Full height gate	1
Full height railing section (MB-15R main section, MB-15D optional section)	
Attaching plates and brackets required for connecting the elements of the turnstile, railing sections, canopy, swing gate	
WRC (consisting of a receiver and two transmitters in the form of key fobs) with a range of up to 40 m	1
SORMAT PFG IR 10-15 anchor bolt M10x60	12
SORMAT PFG IR 16-25 anchor bolt M16x100	1
Turnstile power supply	1
Walkway downlights power supply	1

Technical specifications

Operating voltage	turnstile	24 – 2.4 V DC
	walkway downlights	112 V DC
Current consumption	RTD-15.1 turnstile (except for walkway downlights)	max 4.5 A
	RTD-15.2 turnstile (except for walkway downlights)	max 1.2 A
	walkway downlights	max 0.9 A
Power consumption	RTD-15.1 turnstile (except for walkway downlights)	max. 105 W
	RTD-15.2 turnstile (except for walkway downlights)	30 W
	walkway downlights	10 W
Overall dimensions (LxWxH)	without canopy	1800×1600×2325 mm
	with RTC-15.3 canopy	2379×1807×2594 mm
Passageway width		755 mm
Turnstile weight	with RTC-15.3 canopy	max. 260 kg
	without RTC-15.3 canopy	max. 190 kg
Package dimensions (LxWxH)	box #1	196x40x33 cm
	box #2	226×103×21 cm
	box #3	226×103×21 cm
	box #4	222x103x26 cm
	box #5	216x103x16 cm
Throughput rate	in the single passage mode	20 persons / min
	in the free passage mode	30 persons / min
Mean time to failure		2,000,000 passages

Connection

The turnstile control unit is in the top channel located in the upper part of the turnstile. External cables are connected to the DIN-rail located inside the top channel. All cables are routed to the DIN-rail through the bottom hole in the barrier section on the flange side, then up along the post to the top channel (see "Mounting" section).



RTD-15 Full height rotor turnstile

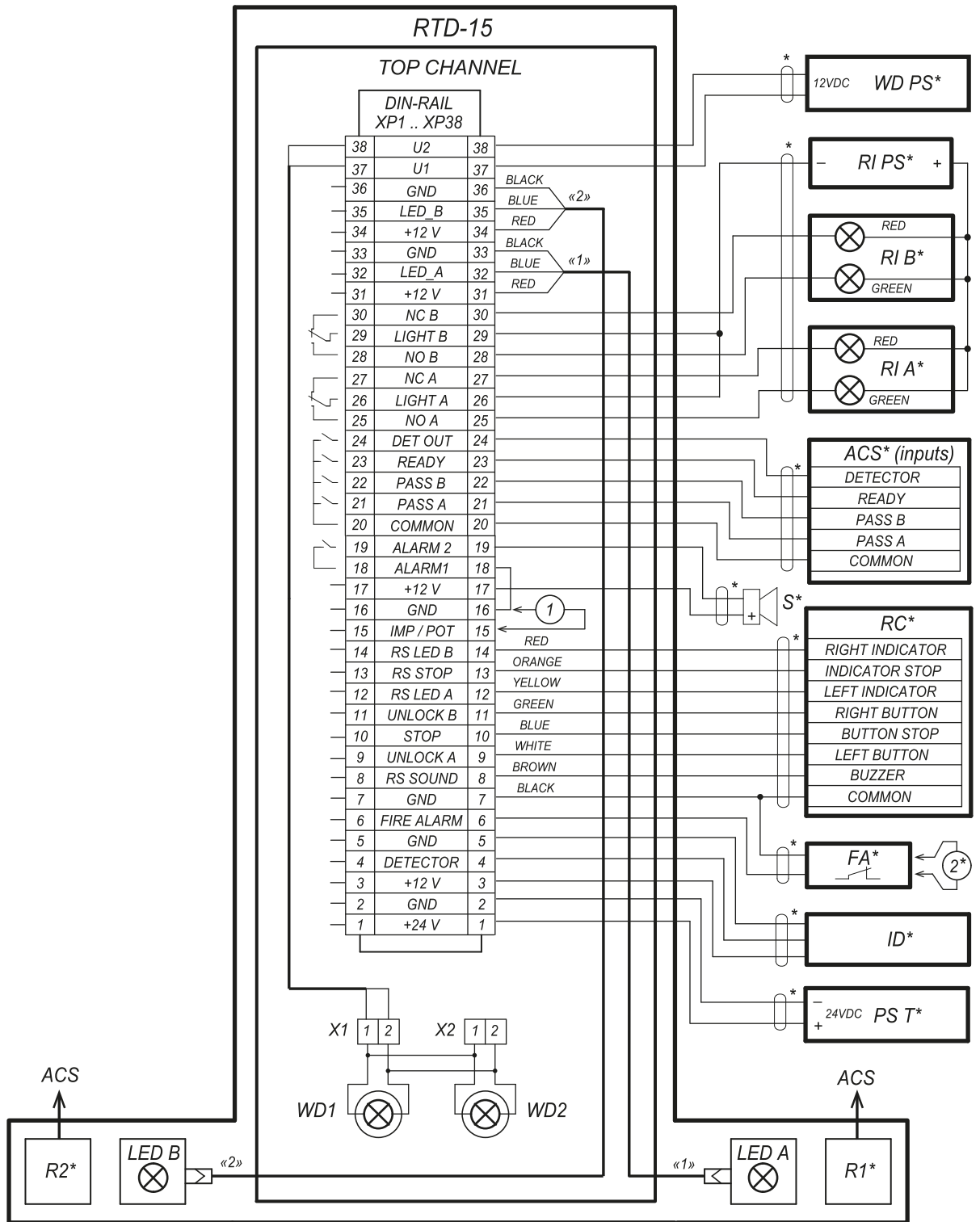

- * - Not included in standard delivery set
- 1 - Wire jumper "IMP / POT".
- 2 - Wire jumper "Fire Alarm" is connected in case there is not Fire Alarm device .

Wiring diagram of external connections to the RTD-15 turnstile



DIN-rail description		
Contact	Electrical circuit	Designation
1, 2	+24 V, GND	Power supply connection
3-5	+12 V, Detector, GND	Intrusion detector connection
6	Fire Alarm	Emergency unlocking input
7	GND	Power supply negative terminal
8	RSSound	RC-panel sound indication output
9-11	UnlockA, Stop, UnlockB	Turnstile control inputs
12-14	RS LedA, RS LedStop, RS LedB	RC-panel indication outputs
15	IMP/POT	Turnstile control mode setting
16	GND	Power supply negative terminal
17	+12 V	Siren and WRC power supply positive terminal
18, 19	Alarm 1, Alarm 2	Alarm relay contacts
20	Common	Common contact for PASS A, PASS B, Ready, Det Out signals
21	PASS A	PASS A relay contact (passage in the direction A)
22	PASS B	PASS B relay contact (passage in the direction B)
23	Ready	Ready relay contact
24	Det Out	Det Out relay contact
25-30	NO, Light, NC	Relay contacts for connecting remote indicators
31-36	+12 V, LED, GND	Contacts for connecting indication blocks located on the guide barrier set
37, 38	U1, U2	Connection of the walkway downlights power supply

Operation algorithm

The turnstile can operate from the RC-panel (included in the delivery set), WRC or ACS controller. The turnstile is controlled by applying a low-level signal to the Unlock A, Stop and Unlock B contacts relative to the GND contact. The turnstile response to these signals depends on the control mode the user has selected (specified by if the IMP/POT jumper wire is installed / removed on the DIN-rail: removed - Pulse control mode, installed - potential control mode).

Pulse control mode is when a pulse is applied to the Unlock A (B) input, the turnstile will automatically open for a single passage in the selected direction. The waiting time for the passage being completed does not depend on the duration of the control pulse and lasts 5 seconds. Sending a pulse to the Stop input locks both passage directions. Simultaneous sending of pulses to Unlock A (B) and Stop inputs places the turnstile in the "Free passage" mode in the selected direction.

Pulse mode is recommended during operation from the RC-panel.

Potential control mode is when the control signal is applied to the Unlock A (B) input, the turnstile remains unlocked in the selected direction during the entire holding signal time. Sending control signal to the Stop input locks both passage directions regardless of the signals at the Unlock A (B) inputs.

Potential mode is recommended during operation from the ACS controller.

Regardless of the selected control mode, Pass A or Pass B signals are generated when moving the barrier sections in one direction or the other. These signals can inform the ACS controller of the fact of passage in the selected direction.

Emergency passage opening is performed by removing a low-level signal from the Fire Alarm contact relative to the GND contact.

Note

When operating the turnstile from the ACS controller, it is recommended to connect the RC-panel to the ACS controller.



RTD-15 Full height rotor turnstile

Example of connection to the ACS

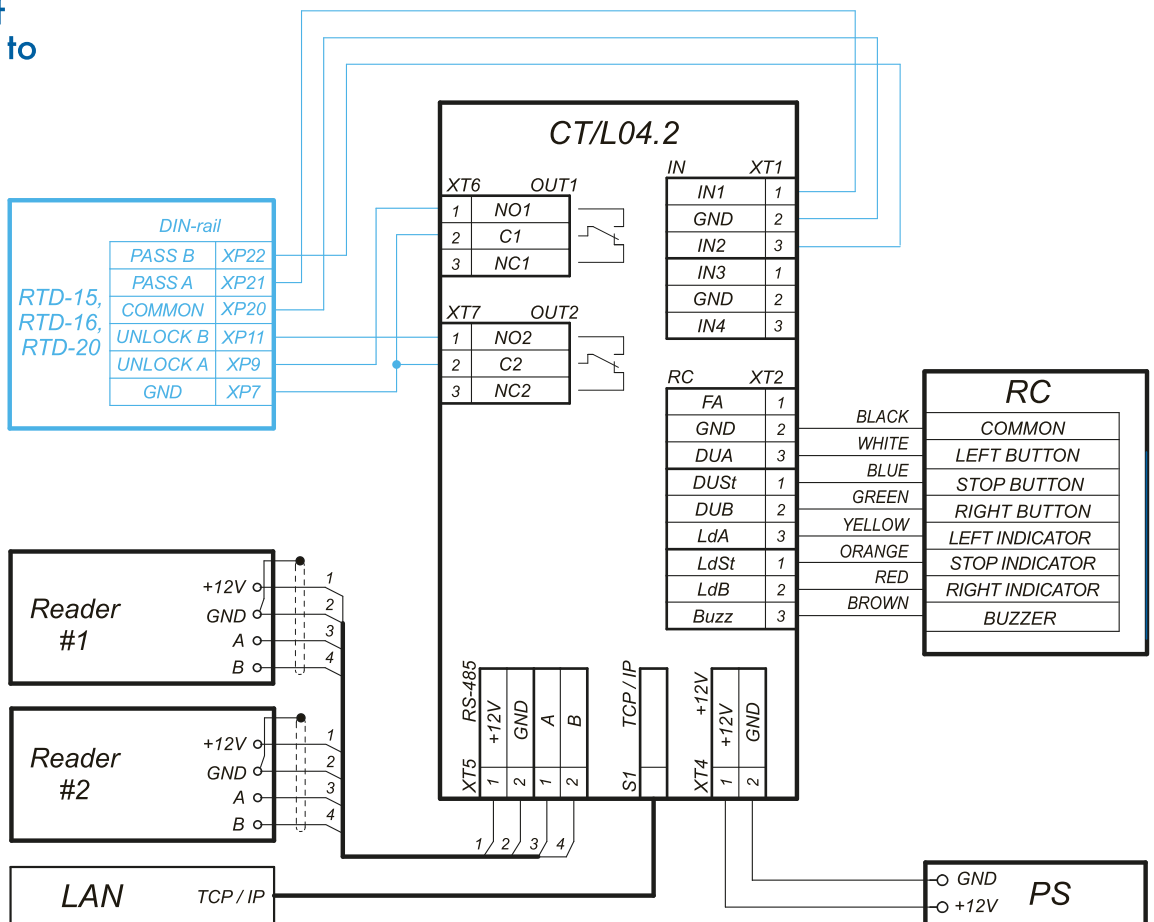

Turnstile connection to the ACS controller (using CT/L04.2 controller as an example)

The maximum allowed cable length of the RC-panel (ACS controller) is 40 meters.

The maximum allowed cable length of the turnstile power supply depends on its cross section and must be: for cables with 0.75 mm² cross-section is 30 meters.



Overall dimensions

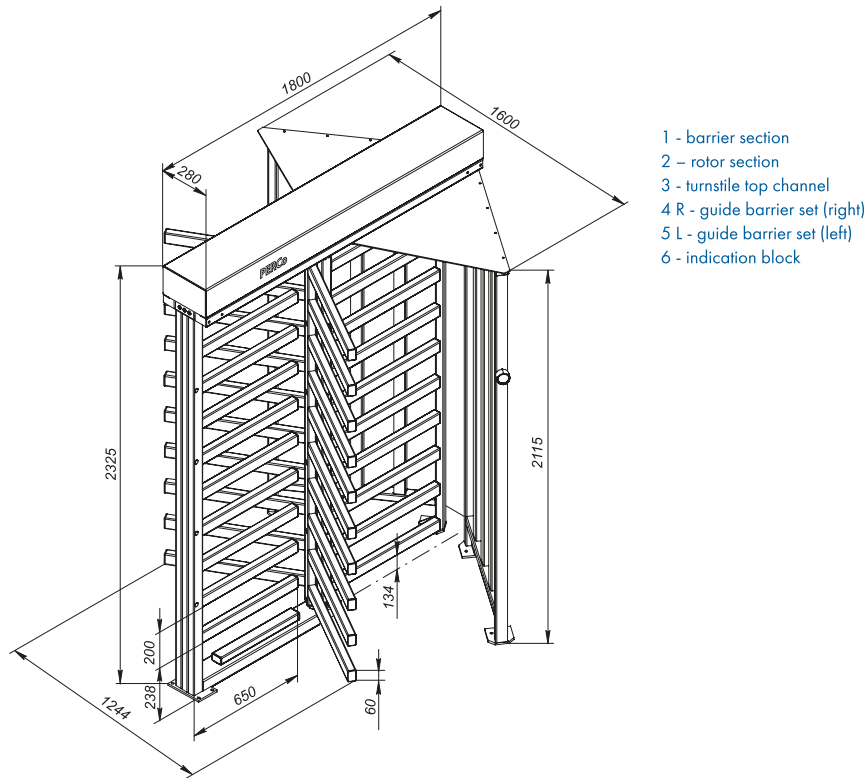

- 1 - barrier section
- 2 - rotor section
- 3 - turnstile top channel
- 4 R - guide barrier set (right)
- 5 L - guide barrier set (left)
- 6 - indication block

Turnstile overall dimensions without canopy

Mounting

Foundation requirements: plain concrete (grade 400 or higher), stone or similar foundations of at least 150 mm thick. For the installation on a less steady foundation it is recommended to apply reinforcing elements (500×500×500 mm) or the RFO1 foundation frame.

When using the foundation frame, hole marking and anchors are not required; the turnstile mounting is more secure.

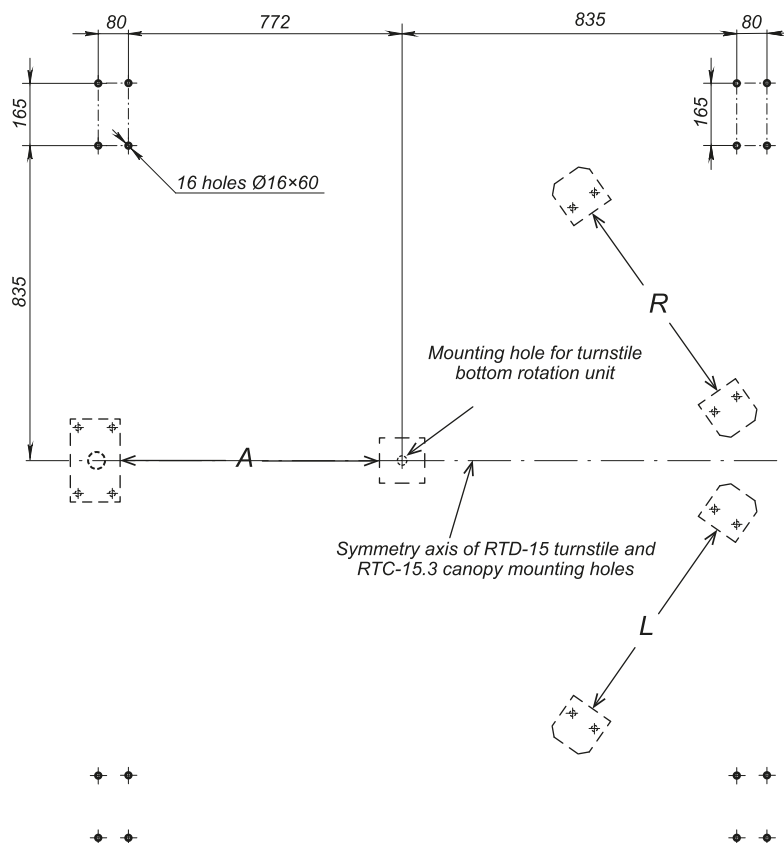

Hole marking



RTD-15 Full height rotor turnstile

It is recommended to place ACS readers on the guide barrier sets near the indication blocks. Readers cable is laid together with indication cable.

Lock-chamber mode is arranged during the installation, home position of the rotor sections should be installed in a corresponding way.

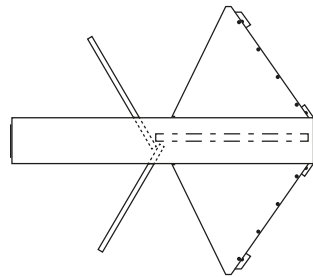

Lock-chamber mode

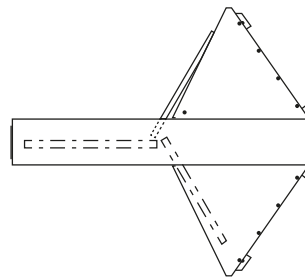

Non-lock-chamber mode

Foundation frame

The RF01 0-01 foundation frame is designed to raise the mounting quality level which makes the RTD-15 turnstile more secure. The Foundation frame is recommended for turnstiles intended for outdoor applications. Bolts, included in the foundation frame delivery set, are used for fixing the turnstile to the foundation frame. The Foundation frame is made of galvanized sheet steel.

Delivery set

Framework 1, framework 2	2
Mounting hardware (set)	1
Certificate	1

Technical specifications

Overall dimensions (LxWxH)	1792x1550x70 mm
Net weight	23 kg

Mounting

Assembled frame is installed on prepared foundation sized 2000x1700 mm and 200-250 mm deep, is leveled with included in the delivery set pins, and is secured not to be moved.

Cable channels are laid (cable channels are allowed to be placed inside the frame).

Concrete (grade not less B22,5) casting of the foundation is to the upper thread bushings for turnstile fixation. Concrete overall thickness must be min. 150 mm.

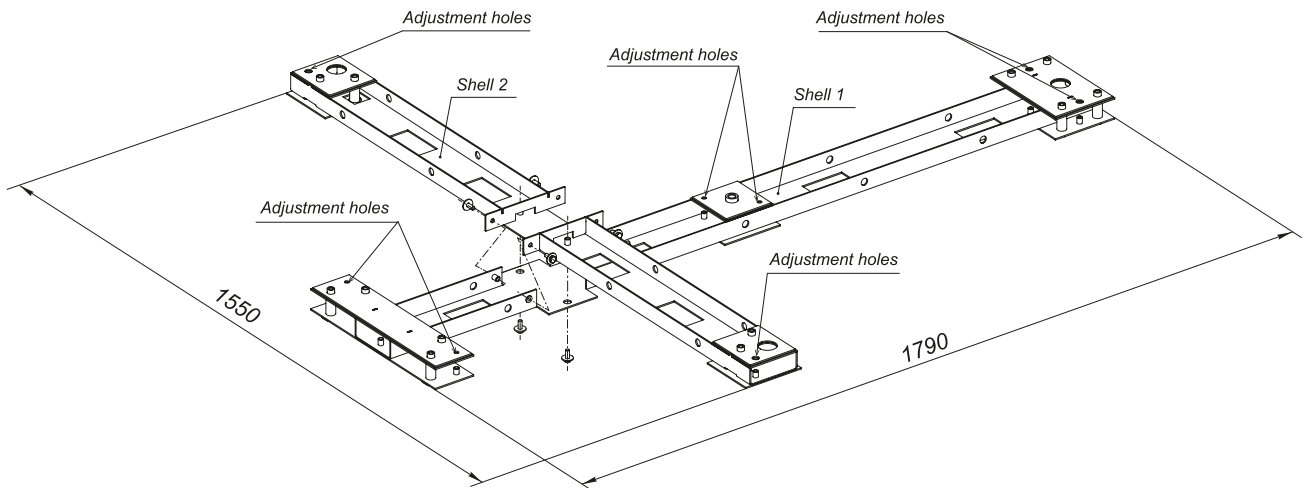

Frame mounting

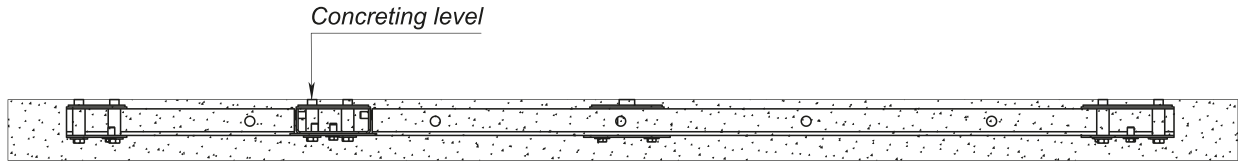

Concrete casting

Canopy

The RTC-15.3 canopy is designed to be used together with the RTD-15 turnstile and to protect the turnstile from precipitation.

Main features:

- high corrosion resistance of the structure made of aluminium alloy provides a long service life in the adverse environmental conditions
- reduced weight providing easy mounting
- high-quality polymer powder coating provides outer appearance at continuous duty

Several turnstiles under canopies can be installed in a row including the cable-laying through the top channels. Brackets and plates are used to connect the turnstile to MB-15 railing sections, wall, WHD-15 gate (see MB-15 railing section description).

Operating conditions

The canopy, with regard to resistance to environmental exposure, complies with GOST 15150-69 category N2 (operation outdoors). The operation of the canopy is allowed at ambient temperature from -40°C to +55°C and relative air humidity up to 98% at + 25°C.

Delivery set

Canopy half-frameworks	2
Post	4
Coupling plate	1
Mounting hardware required for canopy installation	1
Operation Manual	1
Optional equipment (upon request)	
SORMAT PFG IR 10-15 anchor bolt M10x60	16
Attaching plates and brackets required for connecting the elements of the turnstile, railing sections, canopy, security gate	

Technical specifications

Overall dimensions (LxWxH)	2379×1807×2594 mm
Net weight	70 kg
Mean lifetime	8 years
Package dimensions (LxWxH)	
Box #1	191×126×57 cm
Box #2	191×126×57 cm
Box #3	223×53×31 cm



RTD-15 Full height rotor turnstile

Overall dimensions with canopy

Turnstile overall dimensions with canopy are defined by the overall dimensions of the canopy.

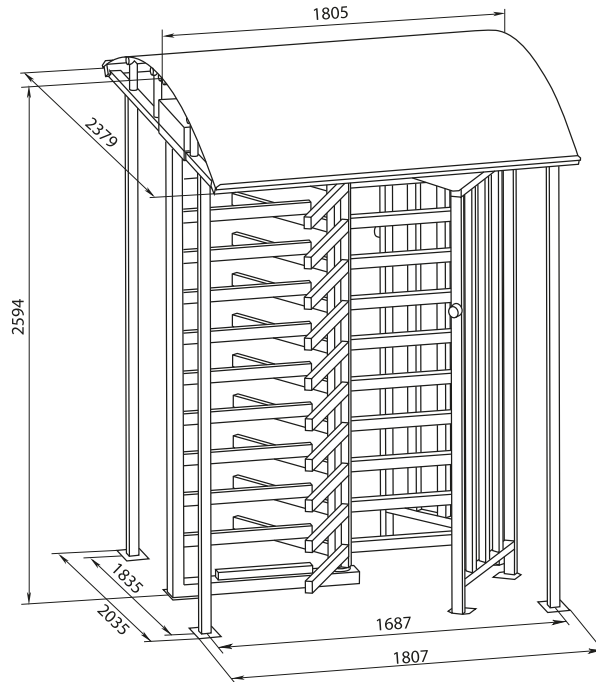

Turnstile overall dimensions with canopy

Canopy foundation requirements are similar to the requirements for the turnstile mounting. The symmetry axes of the turnstile mounting holes are the same. Turnstile overall dimensions with canopy are defined by the overall dimensions of the canopy.

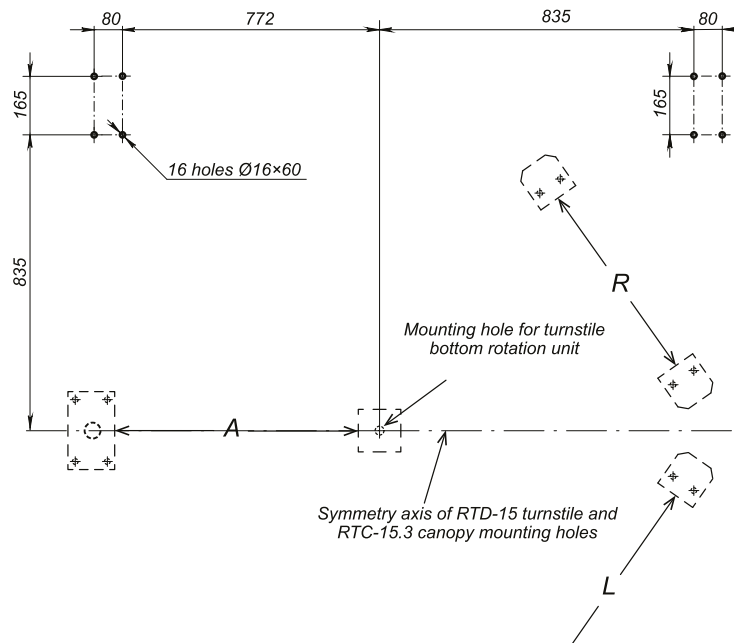

Hole marking for canopy mounting

- A – rotor section fixing point
- L – fixing point for the left section of the guide barrier set
- R – fixing point for the right section of the guide barrier set



Warranty

The warranty period is 5 (five) years commencing from the date of sale, unless otherwise determined in the delivery contract of the Product. In case of sale and installation of the equipment by authorized PERCo dealers and service centers, the warranty starts from the date of commissioning.

Should there be no date of sale on the warranty card, the warranty period shall commence from the date of manufacture specified in the Certificate and on the Product label.



WHD-15 Full height security gate

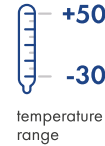

temperature range



operating voltage



persons/min

Application

WHD-15 full height security gate with the electromechanical lock and door latch mechanism is a blocking device designed for people flow management at checkpoints with high-security requirements and at sites where full height coverage is required.

Main features

- unlocking is performed by ACS, a key or control button located on the lock housing (the gate can be unlocked from any side)
- gate locks automatically after the swing panel is back to its home position
- lock can be unlocked remotely from ACS
- swing panel resets to its home position after the passage using the hydraulic door latch mechanism
- passageway width provides access for people with limited mobility accompanied by caregivers and also allows carrying bulky items
- lightweight security gate makes the passage more comfortable
- high corrosion resistance provides a long service life in the adverse environmental conditions
- security gate is produced in the same design as the RTD-15 turnstile and MB-15 full height railing section
- security gate together with RTD-15 turnstiles can be used as an emergency exit
- safe voltage of the lock power supply

Operating conditions

The security gate, with regard to resistance to environmental exposure, complies with GOST 15150-69 category N2 (operation outdoors). The operation of the security gate is allowed at ambient temperature from -30°C to $+50^{\circ}\text{C}$ and relative air humidity up to 98% at $+25^{\circ}\text{C}$.

Design

Housing – powder-coated aluminium structure. Housing colour – light beige with a pearl mica effect. Powder coating to RAL colours is available on order.



Delivery set

Security gate assembly with put-on electromechanical lock	1
Door latch mechanism with fastener	1
Technical documentation (set)	1
Optional equipment (upon request)	
M10 anchor bolt with SORMAT PFG IR 10-15 anchor	4
Attaching plates and brackets required for connecting the elements of the turnstile, railing sections, canopy, security gate	

Technical specifications

Electromechanical lock voltage	from 11.5 to 14 V BC
Current consumption	3 A
Power consumption	36 W
Throughput rate in single passage mode	12 persons / min
Daily average throughput rate in the single passage mode	2000 persons
Passage zone dimensions (HxW)	2110x950 mm
Mean time to failure	1,000,000 passages
Overall dimensions (LxWxH)	2150x1232x378,5 mm
Overall net weight	max. 35 kg
Package dimensions	221x130x23 cm

Connection

When operated from an ACS the lock switches to the "Open" mode and remains so for an unlimited time after a control signal is sent to the lock. When the lock is in the locked mode, after being opened it resets to its home position. The duration of the ACS control signal must be min. 500 ms.

Reed sensor for "Closed" mode control is recommended to be installed on the gate for proper operation of the security gate as a part of ACS.

Overall dimensions

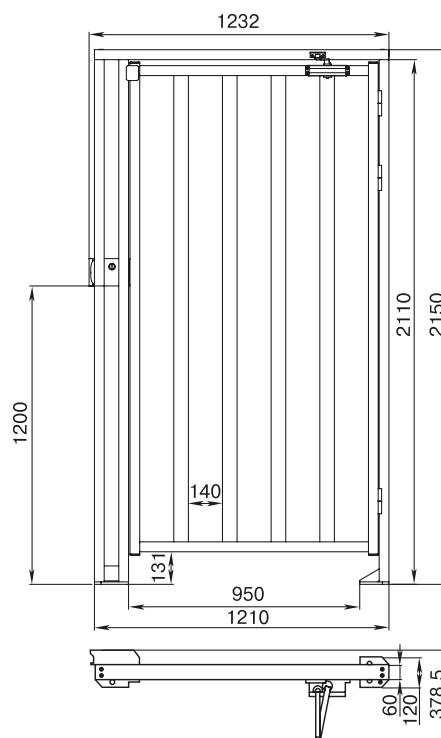

Security gate overall dimensions



WHD-15 Full height security gate

Mounting

Foundation requirements: plain concrete (grade 400 or higher), stone or similar foundations of at least 150 mm thick. For the installation of the security gate on a less steady foundation it is recommended to apply reinforcing elements (450×450×200 mm).

See Fig. for security gate hole marking. There is a hole for control cable laying to the lock in the security gate framework post.

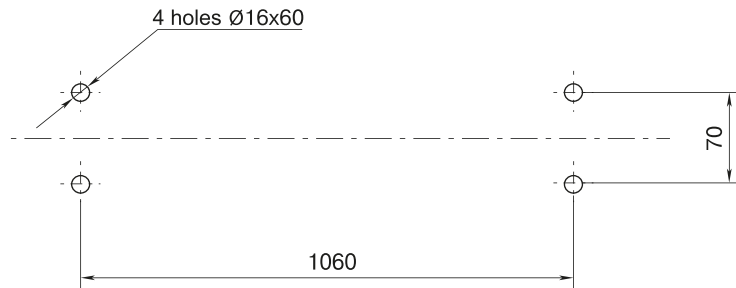

Hole marking for security gate mounting

Warranty

The warranty period is 5 (five) years commencing from the date of sale, unless otherwise determined in the delivery contract of the Product. In case of sale and installation of the equipment by authorized PERCo dealers and service centers, the warranty starts from the date of commissioning.

Should there be no date of sale on the warranty card, the warranty period shall commence from the date of manufacture specified in the Certificate and on the Product label.

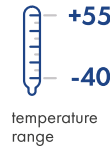

Application

MB-15 railing is designed to segment entrance points into functional areas with high safety requirements for control and full height coverage of the passage zone.

It can be used as a standalone blocking device and as a part of RTD-15 turnstile and WHD-15 security gate, with that, the railing is produced in the same design as above mentioned equipment so that they can form a unique construction. Sections coupling is performed at 180°, 90° angles. There are fixing elements for attaching to a wall (for more information about attaching plates and brackets required for connecting the elements of the turnstile, railing sections, canopy, security gate see page 210).

Two versions of railings are available:

- MB-15R main railing section
- MB-15D additional railing section (the section is not fixed to the ground and is used for filling gaps)

Operating conditions

The railing, with regard to resistance to environmental exposure, complies with GOST 15150-69 category N2 (operation outdoors). The operation of the railing is allowed at ambient temperature from -40°C to +55°C and relative air humidity up to 98% at + 25°C.

Design

Railing sections are made of strong powder coated extruded aluminium. Colour – light beige with pearl mica effect.

Delivery set

Main railing section (MB-15R main section / MB-15D optional section)	1
Operation Manual	1
Optional equipment (upon request)	
M10 anchor bolt with SORMAT PFG IR 10-15 anchor	4
Attaching plates and brackets required for connecting the elements of the turnstile, railing sections, canopy, security gate	



MB-15 Full height railings

Technical specifications

Overall dimensions (LxWxH)	MB-15R main section	820x120x2150 mm
	MB-15D additional section	700*x60x2115 mm
Net weight	MB-15R main section	max. 21.5 kg
	MB-15D additional section	max. 9.4 kg
Package dimensions (LxWxH)		
Main section box		222x93x21 cm
Additional section box		212x77x14 cm

* Can be reduced to 260 mm when installing.

Overall dimensions

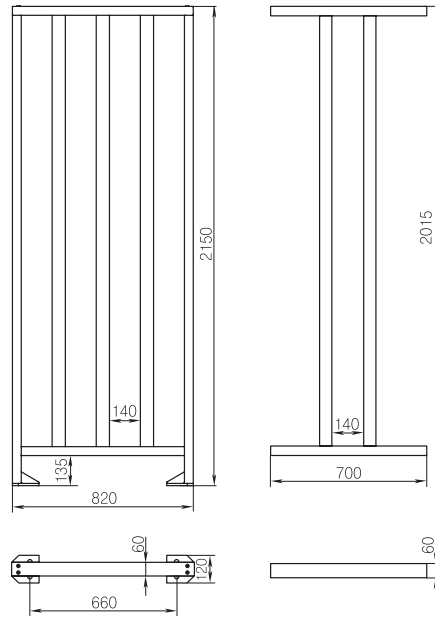

Railing sections overall dimensions

Mounting

Foundation requirements: plain concrete (grade 400 or higher), stone or similar foundations of at least 150 mm thick. For the installation of railing on a less steady foundation it is recommended to apply reinforcing elements (300x300x300 mm).

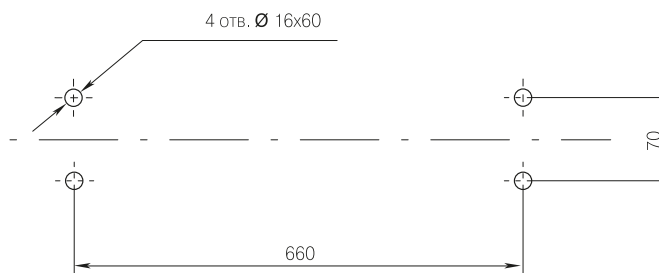

Hole marking for mounting railing sections



Passage zone modeling

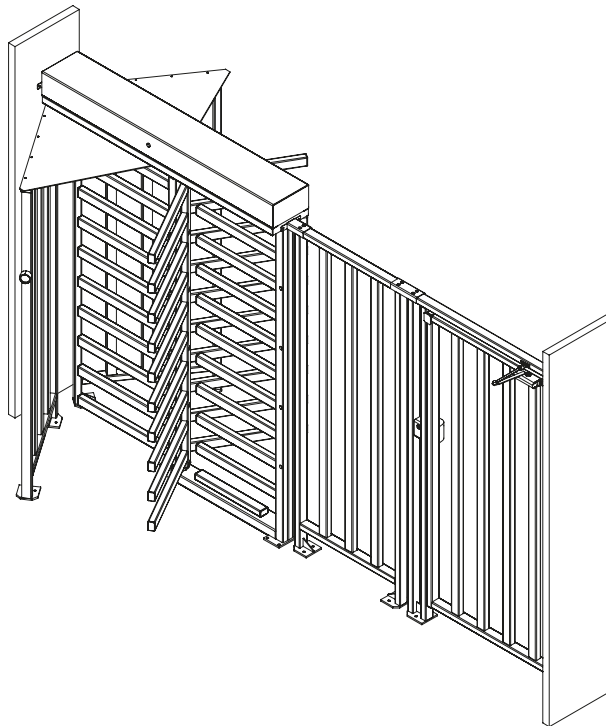

Attaching plates and brackets application

Attaching plates and brackets are required for connecting the elements of the RTD-15 turnstile, RTC-15 canopy, MB-15 railing sections, WHD-15 security gate.

Nº	Item	Description	Mounting layout
1	RF01 0-03	Upper plate for coupling RTD-15 turnstile with WHD-15 or MB-15 railing section (with fastener)	Fig. 1
2	RF01 0-04	Upper angular plate for coupling MB-15 railing sections at 90° (with fastener)	Fig. 2
3	RF01 0-05	Upper plate for coupling MB-15 railing sections / WHD-15 security gate (with fastener)	Fig. 3
4	RF01 0-06	Upper plate for coupling additional MB-15D railing sections with MB-15 section / WHD-15 security gate (with fastener)	Fig. 4
5	RF01 0-07	Lower plate for coupling additional MB-15D railing sections with MB-15 section / WHD-15 security gate or attaching it to a wall (with fastener)	Fig. 5,6
6	RF01 0-08	Upper plate for attaching MB-15 railing section / WHD-15 security gate to a wall (with fastener)	Fig. 7
7	RF01 0-09	Bracket for coupling RTD-15 turnstile with RTC-15 canopy, WHD-15 security gate or MB-15 railing section (with fastener)	Fig. 8
8	RF01 0-10	Bracket for coupling RTD-15 turnstile with RTC-15 canopy (with fastener)	Fig. 9
9	RF01 0-02	Insertion post for filling the gap between RTD-15 turnstiles installed under RTC-15 canopies (with fastener)	Fig. 10
10	RF01 0-11	Bracket for attaching RTD-15 turnstile to a wall (with fastener)	Fig. 11



MB-15 Full height railings

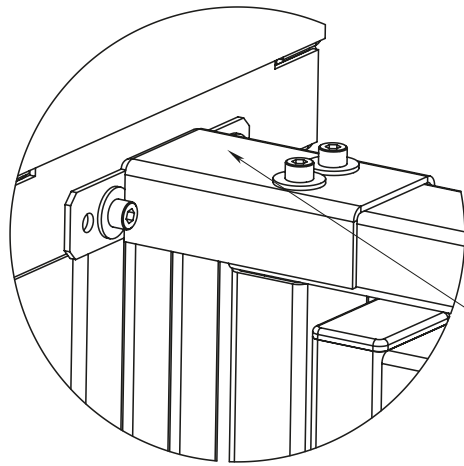

Upper plate RF01 0-03 to join RTD-15 turnstile with WHD-15 full height gate or MB-15 railing section (WHD-15 swing gate)

Picture 1

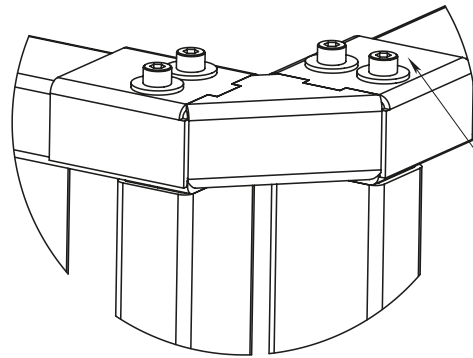

Upper angle plate RF01 0-04 to join MB-15 railing sections (WHD-15 swing gate)

Picture 2

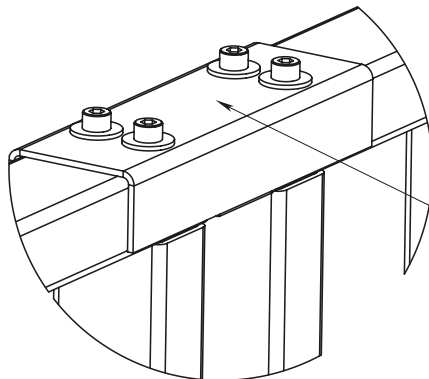

Upper plate RF01 0-06 to join MB-15 railing sections (WHD-15 gate)

Picture 3

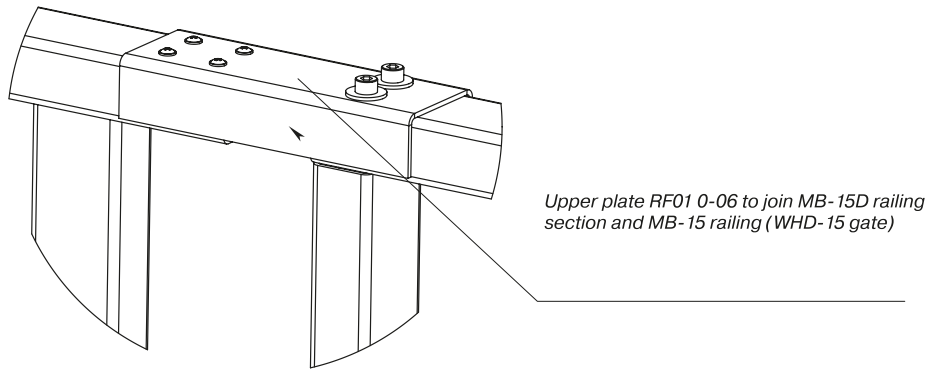

Picture 4

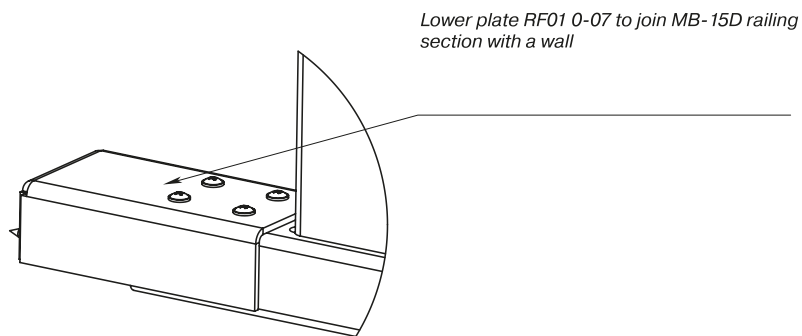

Picture 5

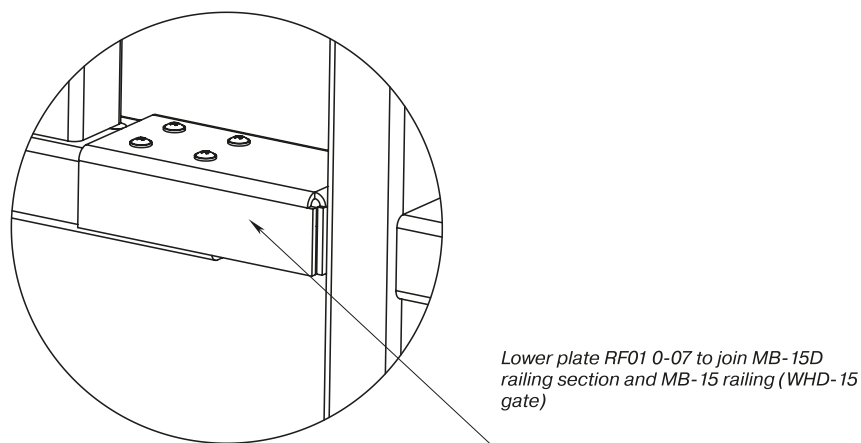

Picture 6



MB-15 Full height railings

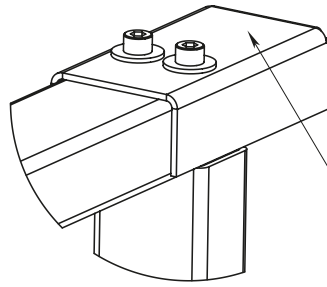

Upper plate RF01 0-08 to join MB-15 railing section (WHD-15 full height gate) with a wall

Picture 7

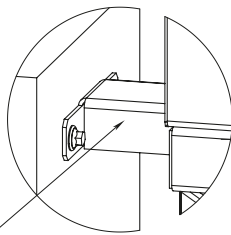

Bracket RF01 0-11 to join RTD-15 turnstile with a wall

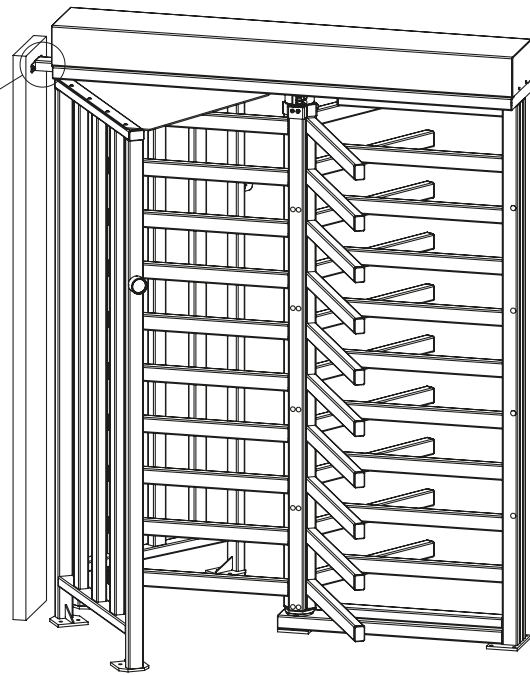

Picture 8

RTD-16 Full height rotor turnstile



+55
-40
temperature range

22-30V
operating voltage

105 W
power consumption

2
passage direction

20
persons/min

mechanical unlocking

motor drive

Application

RTD-16 full height rotor turnstile is a normally closed electromechanical turnstile designed for indoor and outdoor operation.

The following versions of the turnstile are available:

RTD-16.1 – with motor drive. The motor drive is activated at the beginning of the passage through the turnstile once the rotor has turned about 12° and starts rotating in the passage direction till the home (closed) position reached;

RTD-16.2 – mechanical drive. In this case during the passage through the turnstile after the rotor has been turned more than 60°, the actuating mechanism resets the rotor to its home (closed) position.

RTD-16.1S and RTD-16.2S turnstiles are equipped with a stainless steel rotor.

The delivery set includes an RC-panel. Buttons' orientation relative to the passage directions is to be set upon connecting the RC-panel to the turnstile. It is recommended to install one turnstile based on a maximum working load of 20 persons/min. Turnstiles can be equipped with a matching gate and railings.

The turnstile provides passage control in two directions, turnstile operating mode may be set independently for each passage direction. Supported operating modes:



RC-panel

Operating modes

- passage denial in both directions
- single passage in one direction and passage denial in the other direction
- single passage in both directions
- free passage in one direction and passage denial in the other direction
- free passage in one direction and single passage in the other direction
- free passage in both directions
- lock-chamber mode (two-step mode with a pass-through verification, set during installation))
- operation of the turnstile from RC-panel, WRC, ACS
- built into the turnstile housing electronic board
- lock-chamber mode is available



RTD-16 Full height rotor turnstile

Main features

- power and control cables can be routed to the turnstiles through the guide barrier section and through the top channel
- turnstiles can be installed close to each other without gaps and connected elements including installation under canopies
- reverse rotation locking – prevents reverse rotation of the rotor once the rotor has been turned more than 60°
- Fire Alarm control input that allows connecting the emergency unlocking device (for example, fire alarm system)
- Mechanical unlocking with a key is available for each passage direction which provides free rotation in this direction
- built-in hyperluminous LED indicators of the passage grant / denial
- built-in walkway downlights (two 4W LED lamps)
- matching canopy protects the turnstile from precipitations and climbing over
- turnstile can be installed on loose ground using a special mounting frame
- high corrosion resistance provided by galvanized and powder coated elements guarantees a long service life in adverse environmental conditions; "S" version is equipped with a stainless steel rotor.
- high-quality polymer powder coating provides outer appearance at continuous duty
- two control modes – pulse and potential
- possibility to connect an intrusion detector and a siren to the turnstile



Mechanical unlocking with a key



LED indication

Operating conditions

The turnstile, with regard to resistance to environmental exposure, complies with GOST 15150-69 category N2 (operation outdoors). The operation of the turnstile is allowed at ambient temperature from -40°C to +55°C and relative air humidity up to 98% at + 25°C. Top channel protection class – IP54.

The RC-panel, with regard to resistance to environmental exposure, complies with GOST 15150-69 category NF4 (operation in premises with climate control). RC-panel should be operated at ambient air temperature from +1°C to + 55°C and at relative air humidity of up to 80% at +25°C.

Finish – galvanized powder-coated steel; "S" version features a stainless steel rotor.

Design

It is a serially produced product certified for compliance with applicable Russian and European CE standards.

Delivery set

Rotor section	3
Barrier arms section with half-coupling and bottom rotation unit	1
Guide barrier set assembly with indication block and indication cable assembly	2
Top channel	1
Supporting girder	1
Mounting hardware required for elements installation	1
Turnstile	1



Turnstile power cable (15 m)	1
Key to mechanical release locks (2 per each lock)	4 per one main section
Documentation set	1
Spare parts and accessories kit	1
Optional equipment (upon request)	
RF 16 foundation frame	1
RTC-6 canopy	1
WHD-16 full height security gate	1
Full height railing sections (MB-16R main section, MB-16D optional section)	
Attaching plates and brackets required for connecting the elements of the turnstile, railing sections, canopy, swing gate	
WRC (consisting of a receiver and two transmitters in the form of key fobs) with a range of up to 40 m	1
SORMAT PFG IR 10-15 anchor bolt M10x60	12
SORMAT PFG IR 16-25 anchor bolt M16x100	1
Turnstile power supply	1
Walkway downlights with hardware	2
Walkway downlights power supply with cable	1

Technical specifications

Operating voltage	Turnstile	24 ± 2.4 V BC
	Walkway downlights	12 V DC
Current consumption	RTD-16.1 turnstile (except for walkway downlights)	max 4.5 A
	RTD-16.2 turnstile (except for walkway downlights)	max 1.2 A
	Walkway downlights	max 0.8 A
Power consumption	RTD-16.1 turnstile (except for walkway downlights)	max. 105 W
	RTD-16.2 turnstile (except for walkway downlights)	max. 30 W
	Walkway downlights	max. 10 W
Overall dimensions (LxWxH)	Without canopy	160x165x231 cm
	With RTC-16 canopy	242x166x256 cm
Passageway width		630 mm
Turnstile weight	RTD-16.1	max. 191 kg
	RTD-16.2	max. 193 kg
Package dimensions (LxWxH)	Box #1	180x40x34 cm
	Box #2	221x21x98 cm
	Box #3	225x2x98 cm
	Box #4	225x21x98 cm
	Box #5	224x27x98 cm
Throughput rate	In the single passage mode	20 persons / min
	In the free passage mode	30 persons / min
Mean time to failure		2,000,000 passages



RTD-16 Full height rotor turnstile

Connection

The turnstile control unit is in the top channel located in the upper part of the turnstile. External cables are connected to the DIN-rail located inside the top channel. All cables are routed to the DIN-rail through the bottom hole in the barrier section on the flange side, then up along the post to the top channel or through the front end of the top channel (see Sect. "Mounting").

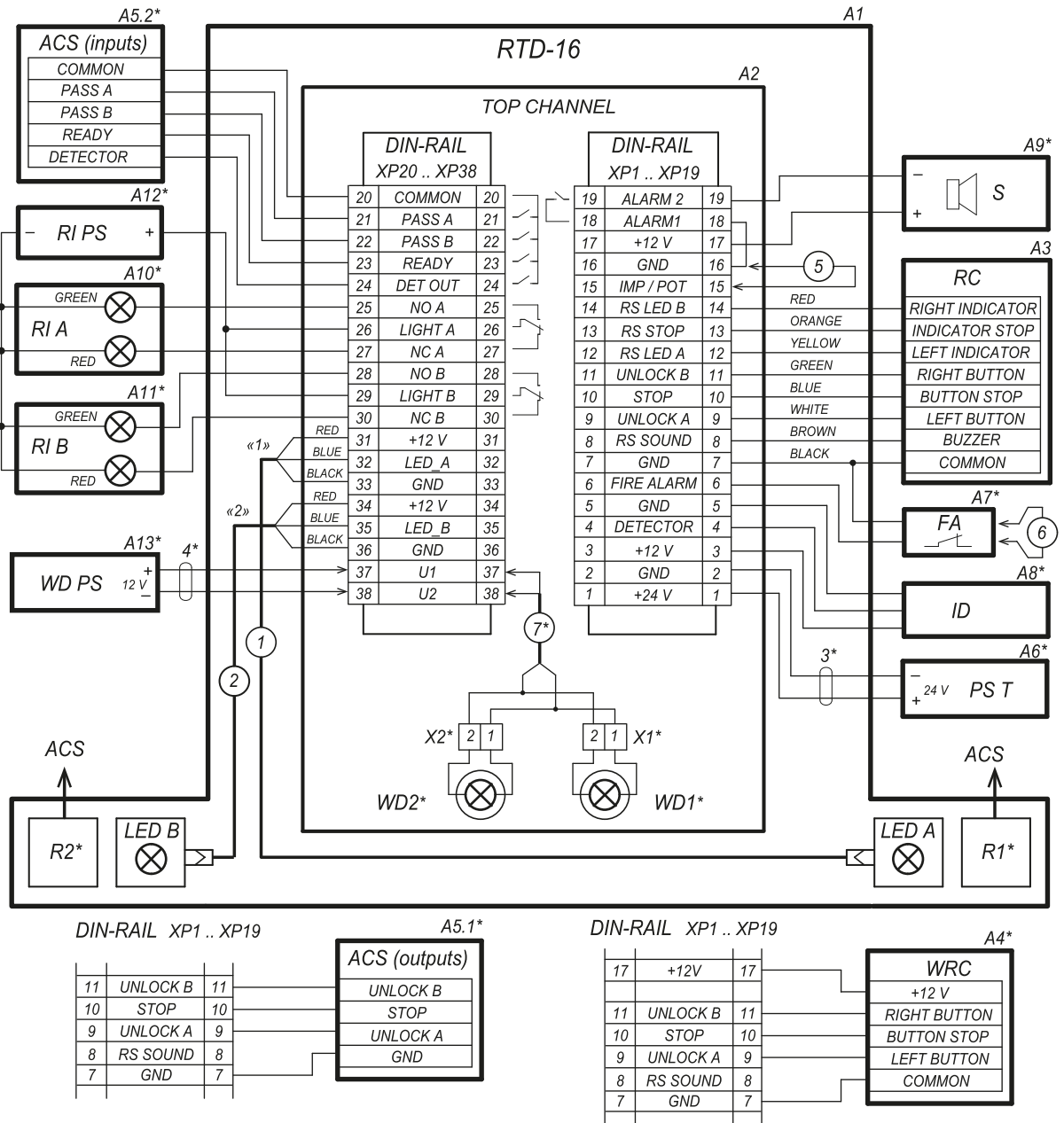

Diagram of external connections to the RTD-15 turnstile

Diagram description	
Item	Description
A1	RTD-16 turnstile
A2	Top channel
A3, A4*	RC-panel, WRC



A5*	ACS controller
A6*	Turnstile power supply (24V, 5A)
A7*	Device that gives an emergency unlocking command
A8*	Intrusion detector
A9*	12V DC siren
A10*, A11*	Remote indicators
A12*	Power supply for additional remote indication
A13*	Power supply for walkway downlights
	Walkway downlights
LED	Indication blocks
R1*, R2*	ACS readers
1, 2	Indication cables
3	Turnstile power cable
4*,7*	Walkway downlights power cables
5	Jumper for switching "Imp./Pot." mode
6	FA Jumper installed, if there is no Fire Alarm device (A7)

* The equipment is not included in the standard delivery set

DIN-rail description		
Contact	Electrical circuit	Designation
1, 2	+24 V, GND	Power supply connection
3-5	+12 V, Detector, GND	Intrusion detector connection
6, 7	Fire Alarm, GND	Emergency unlocking input
8	RC Sound	RC-panel sound indication output
9-11	UnlockA, Stop, UnlockB	Turnstile control inputs
12-14	RS LedA, RS LedStop, RS LedB	RC-panel indication outputs
15, 16	IMP / POT	Turnstile control mode setting
17	+12 V	Output for powering additional devices
18, 19	Alarm 1, Alarm 2	Siren connection outputs
20	Common	Common contact for PASS A, PASS B, Ready, Det Out signals
21	PASS A	PASS A relay contact (passage in the direction A)
22	PASS B	PASS B relay contact (passage in the direction B)
23	Ready	Ready relay contact
24	Det Out	Det Out relay contact
25-30	NO, Light, NC	Relay contacts for connecting remote indicators
31-36	+12 V, LED, GND	Contacts for connecting indication blocks located on the guide barrier set
37, 38	U1, U2	Connection of the walkway downlights power supply

Operation algorithm

The turnstile can operate from the RC-panel (included in the delivery set), WRC or ACS controller.

The turnstile is controlled by applying a low-level signal to the Unlock A, Stop and Unlock B contacts relative to the GND contact. Turnstile response to these signals depends on the control



RTD-16 Full height rotor turnstile

mode the user has selected (specified by if the IMP/POT jumper wire is installed / removed on the DIN-rail.

Pulse control mode is when a pulse is applied to the Unlock A (B) input, the turnstile will automatically open for a single passage in the selected direction. The waiting time for the passage being completed does not depend on the duration of the control pulse and lasts 5 seconds. Sending a pulse to the Stop input locks both passage directions. Simultaneous sending of pulses to Unlock A (B) and Stop inputs places the turnstile in the "Free passage" mode in the selected direction.

Pulse mode is recommended during operation from the RC-panel.

Potential control mode is when the control signal is applied to the Unlock A (B) input, the turnstile remains unlocked in the selected direction during the entire holding signal time. Sending control signal to the Stop input locks both passage directions regardless of the signals at the Unlock A (B) inputs.

Potential mode is recommended during operation from the ACS controller.

Regardless of the selected control mode, Pass A or Pass B signals are generated when moving the barrier sections in one direction or the other. These signals can inform the ACS controller of the fact of passage in the selected direction.

Emergency passage opening is performed by removing a low-level signal from the Fire Alarm contact relative to the GND contact.

Note

When operating the turnstile from the ACS controller, it is recommended to connect the RC-panel to the ACS controller.

Example of connection to the ACS

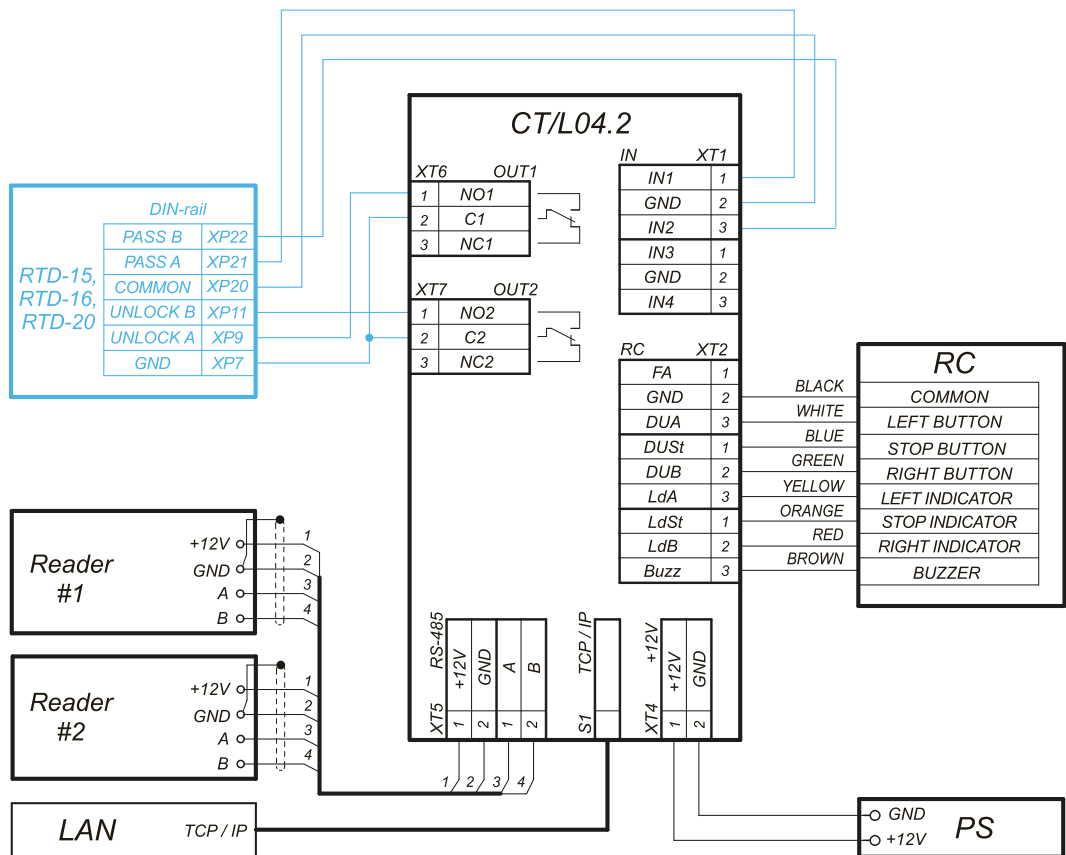

1 - jumper wire, installed if there is no FA device

Turnstile connection to the ACS controller (using CT/L04.2 controller as an example)



The maximum allowed cable length of the RC-panel (ACS controller) is 40 meters.

The maximum allowed cable length of the turnstile power supply depends on its cross section and must be: for cables with 1.5 mm² cross-section is 10 m, for cables with 2.5 mm² cross section - 20 meters.

Overall dimensions

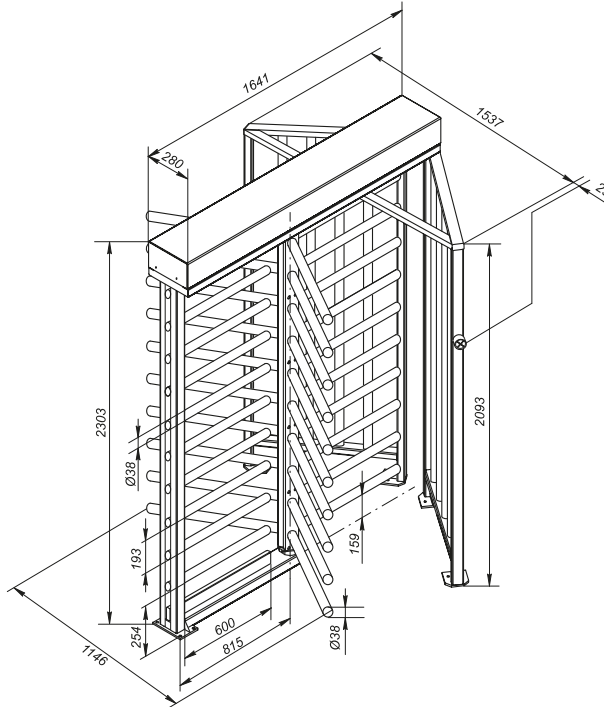

Turnstile overall dimensions without canopy

Mounting

Foundation requirements: plain concrete (grade 400 or higher), stone or similar foundations of at least 150 mm thick. For the installation on a less steady foundation it is recommended to apply reinforcing elements (500×500×500 mm) or RF 16 foundation frame.

When using the foundation frame, hole marking and anchors are not required; the turnstile mounting is more secure.

Hole marking for turnstile installation and cables positioning are shown in Figure.

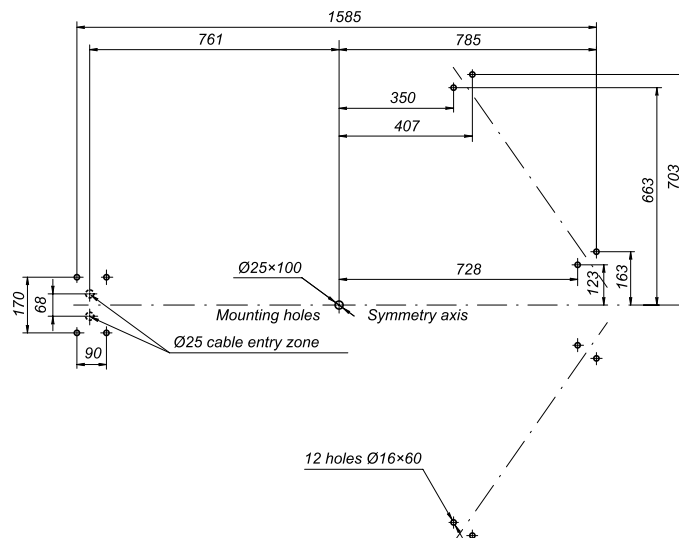

Hole marking



RTD-16 Full height rotor turnstile

Cables of power supply, walkway downlights, RC-panel, ACS and other equipment are routed to the turnstile.

Then above-mentioned cables are routed up through the barrier arm section to the top channel to the DIN-rail contacts.

It is recommended to place ACS readers on the guide barrier sets near the indication blocks.

Lock-chamber mode is arranged during the installation, the home position of the rotor sections should be installed correspondingly.

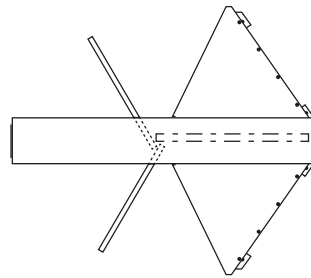

Lock-chamber mode

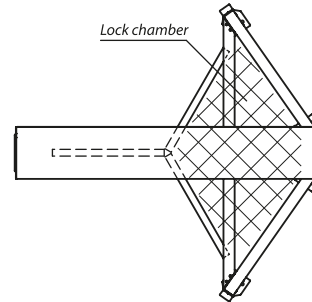

Non-lock-chamber mode

Foundation frame

RF-16 foundation frame is designed to raise the mounting quality level which makes the RTD-16 turnstile more secure. The foundation frame is recommended for turnstiles intended for outdoor applications. Bolts, included in the foundation frame delivery set, are used for fixing the turnstile to the foundation frame.

The foundation frame is made of galvanized sheet steel.

Delivery set

Framework 1, framework 2	2
1 - 4 plates	5
Mounting hardware (set)	1
Certificate	1

Technical specifications

Overall dimensions (LxWxH)	1630x1536x65 mm
Net weight	23 kg

Mounting

Assembled frame is installed on prepared foundation sized 2000x1700 mm and 200-250 mm deep, is levelled with included in the delivery set pins and is secured not to be moved.

Cable channels are to laid (cable channel is allowed to be placed inside the frame).

Concrete (grade not less B22,5) casting of the foundation is to the upper thread bushings for turnstile fixation.

Concrete overall thickness must be min. 150 mm.

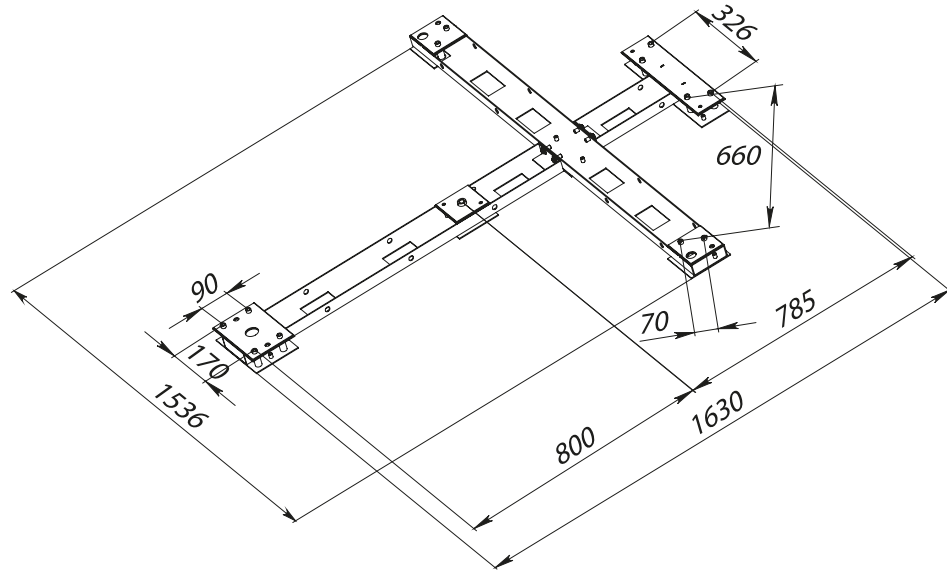

Frame mounting

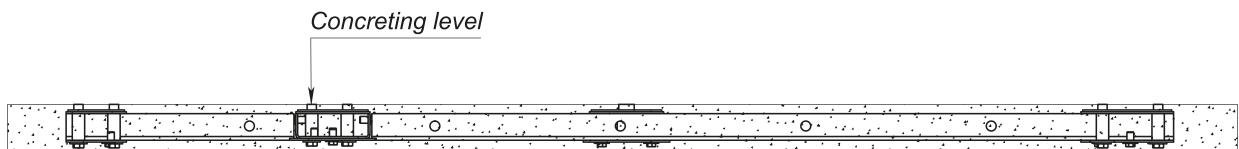

Concrete casting

Canopy

RTC-16 canopy is designed to be used together with the RTD-16 turnstile and to protect the turnstile from precipitations.

Main features:

- due to all elements being galvanized and powder coated, high corrosion resistance provides a long service life in the adverse environmental conditions
- reduced weight providing easy mounting
- high-quality polymer powder coating provides outer appearance at continuous duty
- several turnstiles can be installed in a row

Operating conditions

The canopy, with regard to resistance to environmental exposure, complies with GOST 15150-69 category N2 (operation outdoors). The operation of the canopy is allowed at ambient temperature from -40°C to +45°C and relative air humidity up to 98% at + 25°C.

Canopy

Left/right half-framework	2
Post with brackets	4
Coupling plate	1
Mounting hardware required for canopy installation	1
Operation Manual	1
Optional equipment (upon request)	
SORMAT PFG IR 10-15 anchor bolt M10x60	16



RTD-16 Full height rotor turnstile

Technical specifications

Overall dimensions (LxWxH)	242x166x256 cm
Net weight	max. 82 kg
Mean lifetime	8 years
Package dimensions (LxWxH)	
Box #1	180x137x62 cm
Box #2	222x45x30 cm

Overall dimensions with canopy

Turnstile overall dimensions with canopy are defined by the canopy overall dimensions.

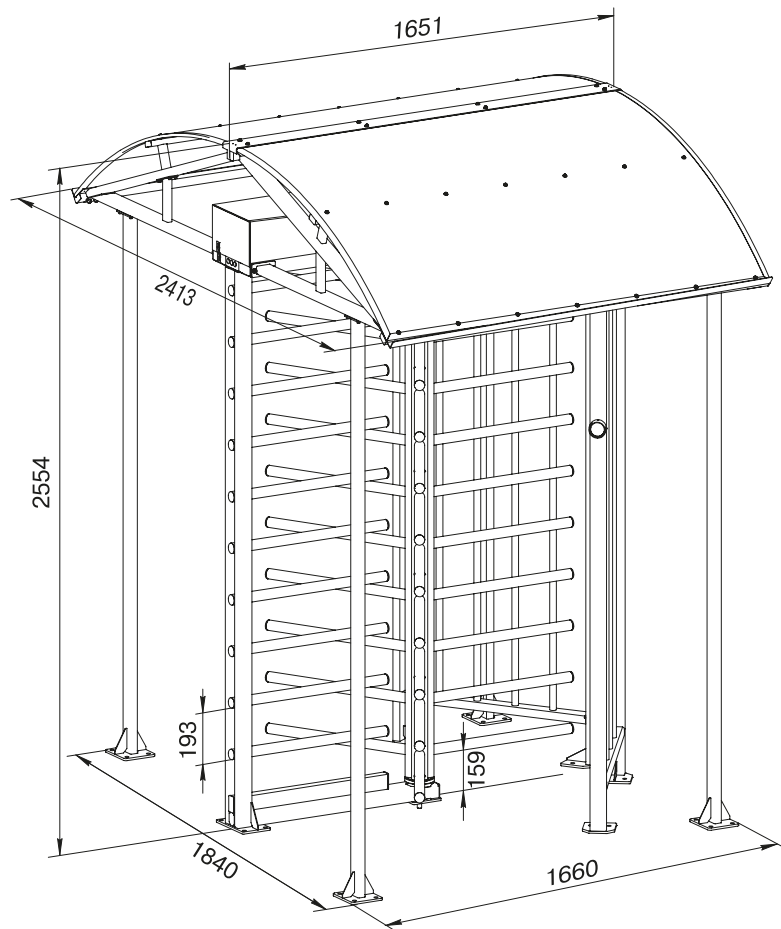

Turnstile overall dimensions with canopy

Canopy foundation requirements are similar to the requirements for the turnstile mounting. The symmetry axes of the turnstile mounting holes are the same.

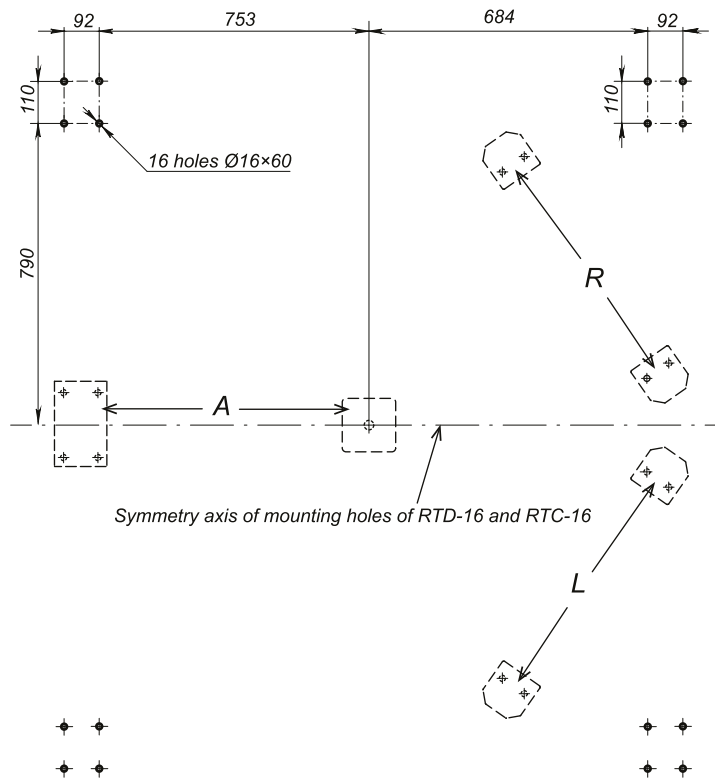

Hole marking for canopy mounting

A – rotor section fixing point

L – fixing point for the left section of the guide barrier set

R – fixing point for the right section of the guide barrier set

Warranty

The warranty period is 5 (five) years commencing from the date of sale, unless otherwise determined in the delivery contract of the Product. In case of sale and installation of the equipment by authorized PERCo dealers and service centers, the warranty starts from the date of commissioning.

Should there be no date of sale on the warranty card, the warranty period shall commence from the date of manufacture specified in the Certificate and on the Product label.



RTD-20 Full height rotor turnstile



+55
-40
temperature range

22-30V
operating voltage

210W
power consumption

2
passage direction

40
persons/min

mechanical unlocking

M
motor drive

Turnstiles, gates and railings

Application

RTD-20 full height double rotor turnstile is a doubled version of RTD-16 full height rotor turnstile i.e. it features two passage lanes. This turnstile allows saving more than 25% of the passageway width compared with two RTD-16 turnstiles installed in a row.

Turnstile is available in two versions:

- RTD-20.1 – with the motor drive of automatic resetting
- RTD-20.2 – with the mechanical drive of resetting

RTD-20.1S and RTD-20.2S turnstiles are equipped with a stainless steel rotor.

Two RC-panels are included in the standard delivery set, one for each passage zone. Buttons orientation relative to the passage directions is to be set upon connecting the RC-panel to the turnstile.

It is recommended to install one turnstile based on a maximum working load of 20 persons/min. Turnstiles can be equipped with a matching gate and railings.



RC-panel

Operating modes

Each passage zone provides passage control in two directions, operating mode may be set independently for each passage direction of both passage zones. Supported operating modes:

- passage denial in both directions
- single passage in one direction and passage denial in the other direction
- successive single passage in both directions
- free passage in one direction and passage denial in the other direction
- free passage in one direction and single passage in the other direction
- free passage in both directions
- lock-chamber mode (two-step mode with a pass-through verification, set during installation)

The product is a normally closed device. When de-energized, the rotor is locked in its home position.



Main features

- operation of the turnstile from RC-panel, WRC, ACS
- built-in control units for each passage zone
- lock-chamber mode is available
- power and control cables can be routed to the turnstiles through the special cable duct and through the top channel
- turnstiles can be installed close to each other without gaps and connected elements including installation under canopies
- reverse rotation locking – prevents reverse rotation of the rotor once the rotor has been turned more than 60°.
- Fire Alarm control input that allows connecting the emergency unlocking device (for example, fire alarm system)
- each passage direction of both passage zone features mechanical unlocking with a key
- built-in hyperluminous LED indicators of the passage grant / denial
- built-in walkway downlights (four 4W LED lamps)
- optional matching canopy protects the turnstile from precipitations and climbing over
- turnstile can be installed on loose ground using optional mounting frame
- high corrosion resistance provided by galvanized and powder coated elements guarantees a long service life in adverse environmental conditions; "S" version is equipped with a stainless steel rotor
- two control modes – pulse and potential
- possibility to connect an intrusion detector and a siren to the turnstile



Mechanical unlocking with a key



LED indication

Operating conditions

The turnstile, with regard to resistance to environmental exposure, complies with GOST 15150-69 category N2 (operation outdoors). The operation of the turnstile is allowed at ambient temperature from -40°C to +55°C and relative air humidity up to 98% at + 25°C. Top channel protection class – IP54.

RC-panel, with regard to resistance to environmental exposure, complies with GOST 15150-69 category NF4 (operation in premises with climate control). RC-panel should be operated at ambient air temperature from +1°C to + 55°C and at relative air humidity of up to 80% at +25°C.

Design

Finish – galvanized powder-coated steel; "S" version features a stainless-steel rotor.

Colour – blue. Powder coating to RAL colours is available on order.

It is a serially produced product certified for compliance with applicable Russian and European CE standards.

Delivery set

Top channel with cover	1
Rotor section with hardware kit	3
Guide barrier set with indication block and indication cable assembly	2
Supporting girder of the guide barrier set	1
Section divider	2
Upper girder of the section divider	1
Lower rotor support with bottom rotation unit	1
Cable duct for cable laying from the bottom	1
Keys to mechanical release locks	8
RC-panel with cable	1



RTD-20 Full height rotor turnstile

Documentation set: Certificate and Operation manual	1
HDF marking template	1
Spare parts, accessories and hardware kit	1
Optional equipment (upon request)	
RF20 foundation frame	1
RTC-20 canopy	1
WHD-16 Full height security gate	1
MB-16 full height railing sections	1
Attaching plates and brackets for coupling turnstiles, railings, security gates, etc.	required number
WRC (consisting of a receiver and transmitters in the form of key fobs) with a range of up to 40 m	2
Turnstile power supply (24 V DC)	1
Walkway downlights power supply (12 V DC)	1
M10×60 bolt with PFG IR 10-15 anchor (SORMAT company, Finland)	24
M16×100 bolt with PFG IR 16-25 anchor (SORMAT company, Finland)	1

Technical specifications

Operating voltage	turnstile	24 – 2.4 V DC
	walkway downlights	12±1.2 V DC
Current consumption for each passage zone	RTD-20.1	max 4.5 A
	RTD-20.2	max 1.2 A
	walkway downlights	max 0.8 A
	RTD-20.1	max. 105 W
Power consumption current for each turnstile	RTD-20.2	30 W
	walkway downlights	10 W
Throughput rate for each passage lane	in the single passage mode	20 persons / min
	in the free passage mode	30 persons / min
Overall dimensions	without canopy	2480x1595x2303 mm
	with RTC-20 canopy	2485x1840x2558 mm
Turnstile weight	RTD-20.1	max. 370 kg
	RTD-20.2	max. 375 kg
Width of each passage zone		630 mm
Mean time to failure for each passage zone		2,000,000 passages
Mean lifetime		8 years

Connection

Control units are located in the top channel in the upper part of the turnstile. External cables are connected to the DIN-rail located inside the top channel.

Cables are routed to the DIN-rail: from below through the cable duct (included in the delivery set), on top through the cable bushings at the front end of the top channel or between two turnstiles through the special bracket.

Turnstiles, gates and railings

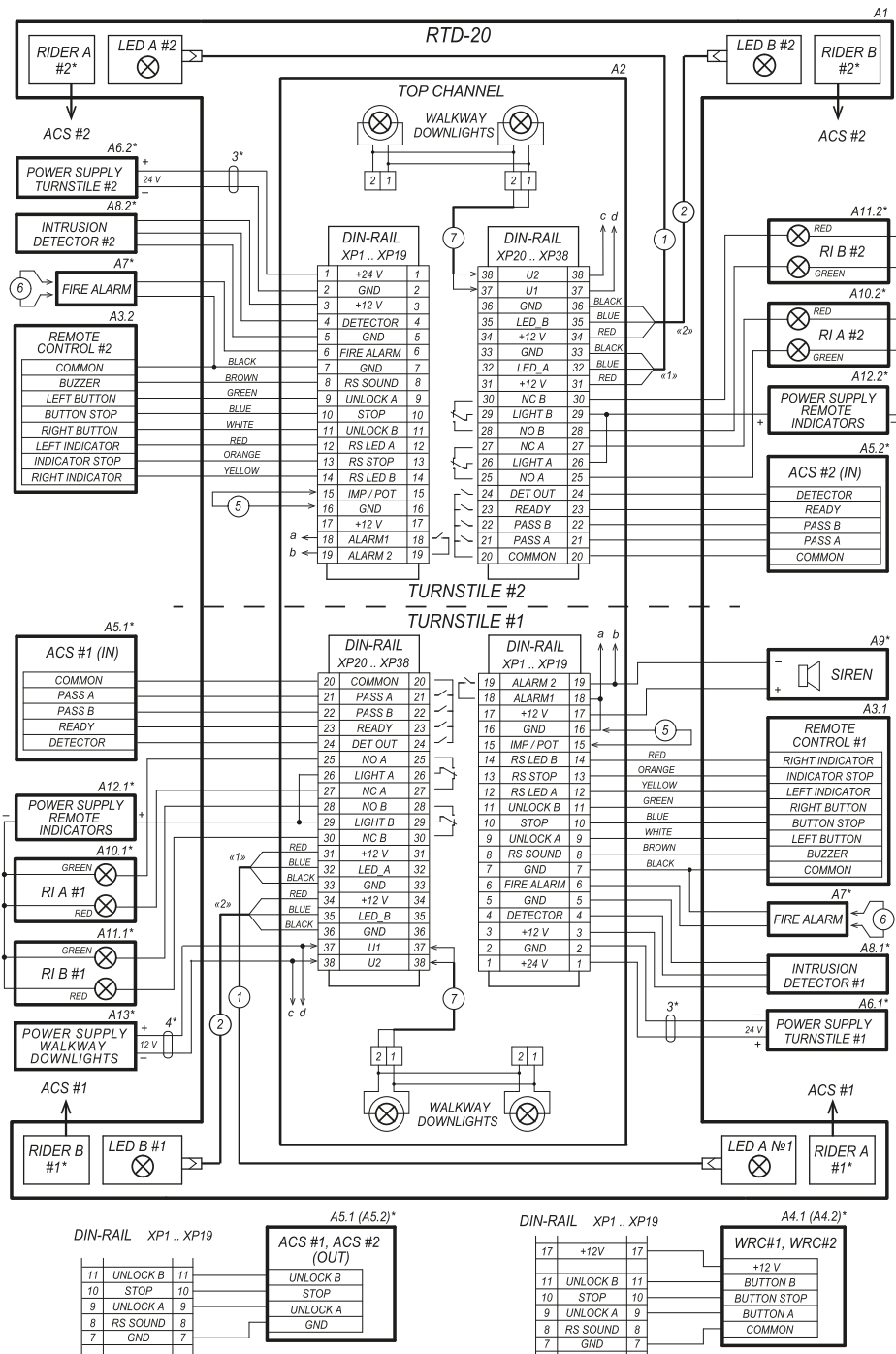

* Not included in standard delivery set

Wiring diagram to the RTD-20 turnstile

Diagram description	
Item	Description
A1	RTD-20 turnstile
A2	Top channel
A3, A4	RC-panel (#1 and #2), WRC (#1 and #2)
A5	ACS controllers (#1 and #2)
A6	+24V / 5.5A Turnstile power supplies (#1 and #2)
A7	Device that gives Fire Alarm emergency unlocking command
A8	Intrusion detectors (#1 and #2)
A9	+12V siren
A10, A11	Remote indicators of directions A and B
A12, A12	Power supplies for remote indicators



RTD-20 Full height rotor turnstile

A13	Walkway downlights power supply (+12 V / 3 A)
	Walkway downlights
LED	Indication blocks of passage directions A and B
RA, RB	ACS readers
1, 2	Indication cables
3	Passage zones power cables
4	External cable for powering walkway downlights
5	Jumpers for switching "IMP/POT" mode
6	Fire Alarm jumpers are connected if there is no Fire Alarm device (A7)

DIN-rail description		
Contact	Electrical circuit	Designation
1, 2	+24 V, GND	Power supply connection
3-5	+12 V, Detector, GND	Intrusion detector connection
6, 7	Fire Alarm, GND	Emergency unlocking input
8	RC Sound	RC-panel sound indication output
9-11	UnlockA, Stop, UnlockB	Turnstile control inputs
12-14	RS LedA, RS LedStop, RS LedB	RC-panel indication outputs
15, 16	IMP / POT	Turnstile control mode setting
17	+12 V	Output for powering additional devices
18, 19	Alarm 1, Alarm 2	Siren connection outputs
20	Common	Common contact for PASS A, PASS B, Ready, Det Out signals
21	PASS A	PASS A relay contact (passage in the direction A)
22	PASS B	PASS B relay contact (passage in the direction B)
23	Ready	Ready relay contact
24	Det Out	Det Out relay contact
25-30	NO, Light, NC	Relay contacts for connecting remote indicators
31-36	+12 V, LED, GND	Contacts for connecting indication blocks located on the guide barrier set
37, 38	U1, U2	Connection of the walkway downlights power supply

Operation algorithm

Each passage zone can operate from the RC-panel (included in the delivery set), WRC or ACS controller. Operation is performed by applying a low-level signal to unlock A, Stop and Unlock B contacts relative to the GND contact. Response to these signals depends on the control mode the user has selected (specified by if the IMP/POT jumper wire is installed / removed on the DIN-rail of the passage zone).

Pulse control mode is when a pulse is applied to the Unlock A (B) input, the passage zone rotor will automatically unlock for a single passage in the direction A (B). The waiting time for the passage being completed does not depend on the duration of the control pulse and lasts 5 seconds. Sending a pulse to the Stop input locks the rotor in both passage directions.

Simultaneous sending of pulses to the Unlock A (B) and Stop inputs places the passage zone in the "Free passage" mode in the selected direction.

It is recommended to use pulse mode during operation from RC-panel or WRC. The orientation of RC-panel buttons can be changed by swapping the wires from the RC-panel that are connected to the unlock A and Unlock B contacts, as well as Led A and Led B, respectively.

Potential control mode is when the control signal is applied to the Unlock A (B) input, the passage zone rotor unlocks in the selected direction during the entire holding signal time.

Turnstiles, gates and railings

Sending control signal to the Stop input locks the rotor regardless of the signals at the Unlock A (B) inputs.

Potential mode is recommended during operation from the ACS controller.

Regardless of the selected control mode, PASS A or PASS B signals are generated when passing in one direction or the other. These signals can inform the ACS controller of the fact of passage.

Emergency passage opening is performed by removing a low-level signal from the Fire Alarm contact relative to the GND contact. Note:

When operating the speed gate from the ACS controller, it is recommended to connect the RC-panel to the ACS controller.

The maximum allowed cable length of the RC-panel (ACS controller) is 40 meters.

The maximum allowed cable length of the power supply depends on its cross section and must be:

- for 1.5 mm² cable – 10 meters
- for 2.5 mm² cable – 20 meters

Example of connection to the ACS

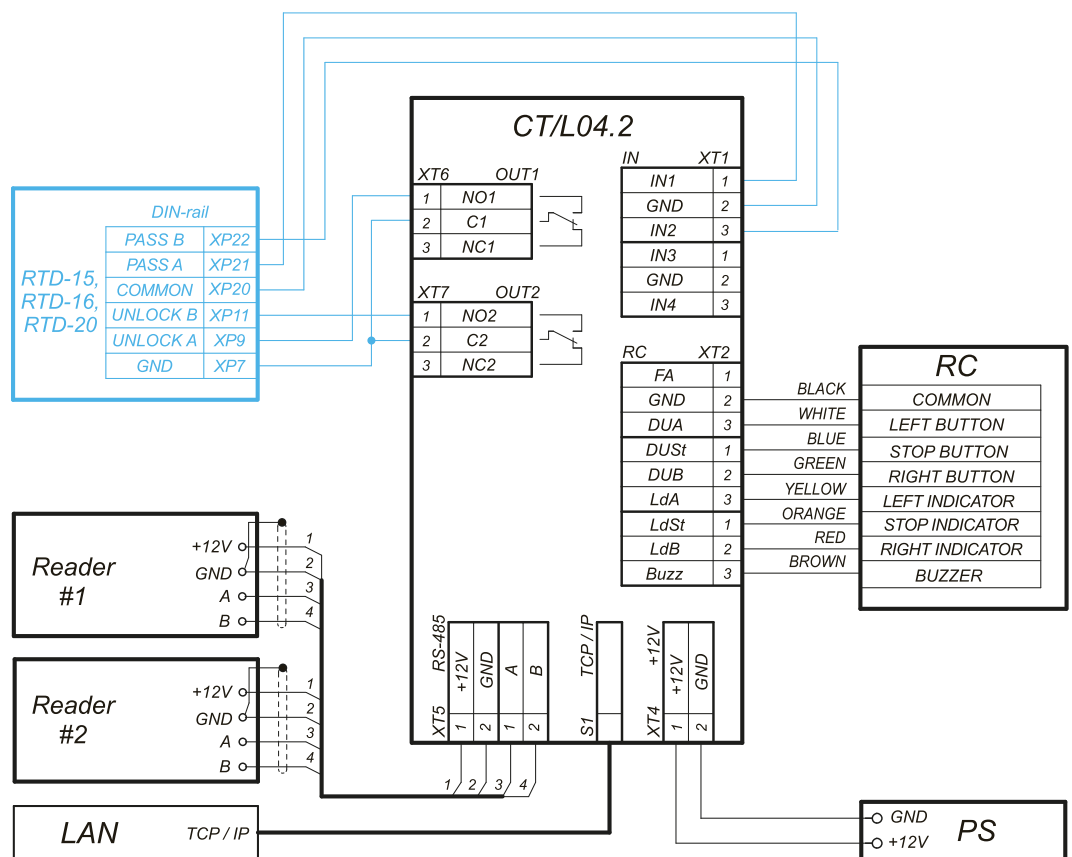

Example of one passage zone connection to the ACS controller



RTD-20 Full height rotor turnstile

Overall dimensions

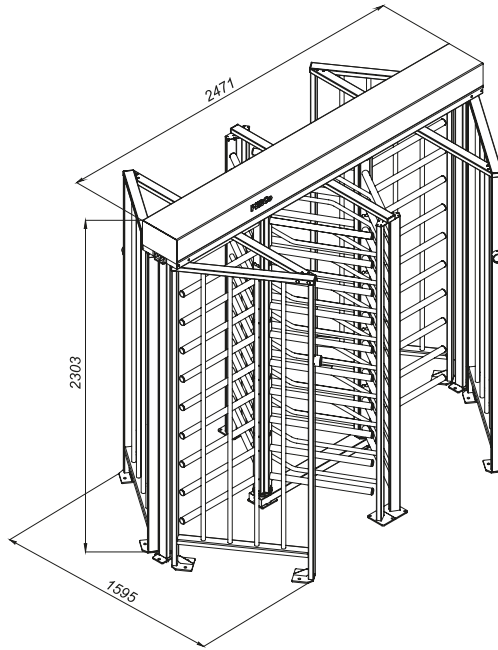

Overall dimensions

Overall dimensions

Foundation requirements: concrete (grade 400 or higher), stone or similar foundations of at least 150 mm thick, when installing the turnstile on a less steady foundation, it is recommended to apply reinforcing elements (500x500x500 mm) or RF-20 foundation frame.

When using the foundation frame, hole marking and anchors are not required; in this case, the turnstile mounting is more secure.

Hole marking, cable duct for cable-laying, turnstile with security gate and railing section mounting layouts are shown in Figures.

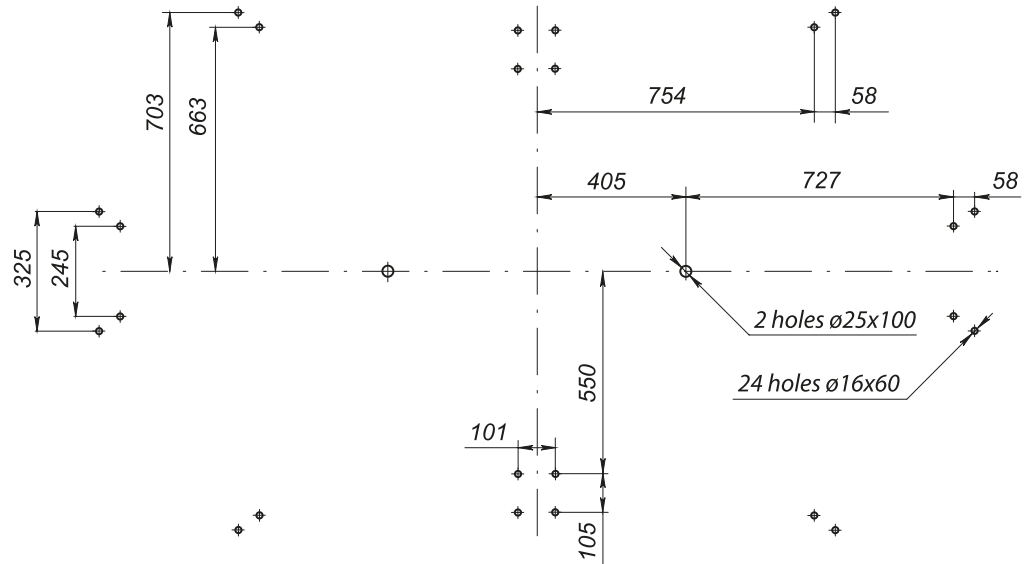

Hole marking for turnstile mounting

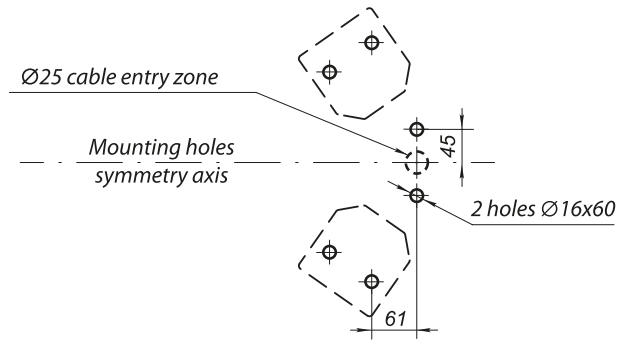

Hole marking for cable duct mounting

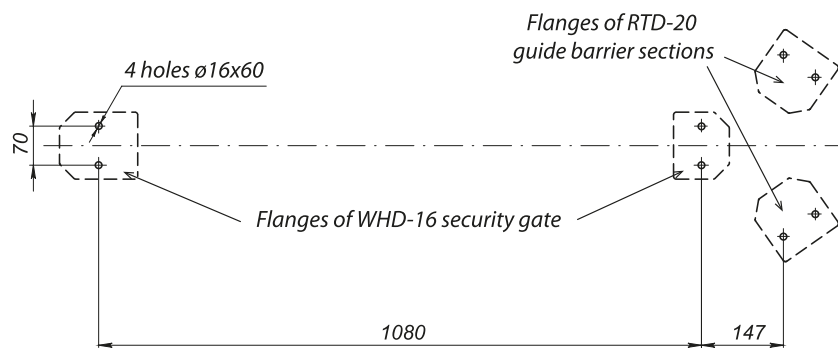

Hole marking for mounting turnstile and WHD-16 security gate

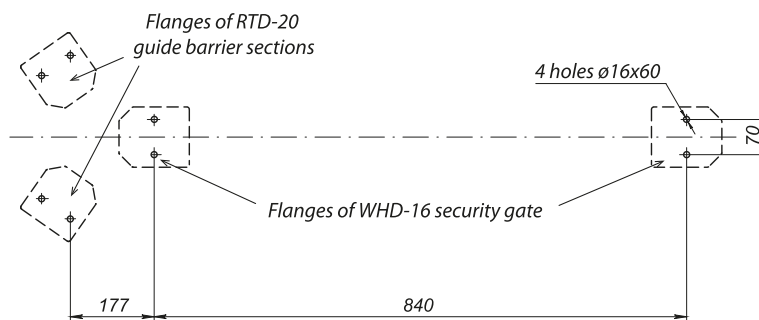

Hole marking for mounting turnstile and MB-16 security gate

HDF marking template is provided for easier marking. It is recommended to place ACS readers on the guide barrier sets near the indication blocks.

Lock-chamber mode is arranged during the installation, the home position of the rotor sections should be installed in a corresponding way.



RTD-20 Full height rotor turnstile

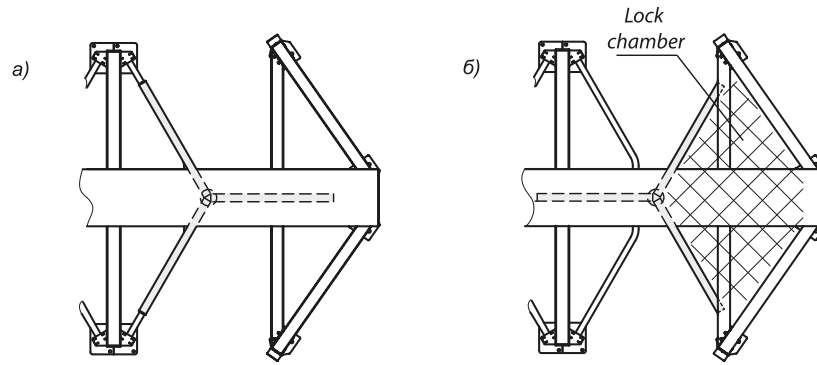

Rotor home position (top view):
a - for standard passage mode, – б - for lock-chamber mode

Foundation frame

RF-20 foundation frame is designed to raise the mounting quality level which makes the turnstile more secure during operation. The foundation frame is recommended for turnstiles intended for outdoor applications. Bolts, included in the foundation frame delivery set, are used for fixing the turnstile to the foundation frame.

The foundation frame is made of galvanized sheet steel.

Frameworks 1, 2, 3	5
Mounting hardware (set)	1
Installation instruction	1

Overall dimensions (length x width x height) – 2548x1536x65 mm. Weight – max. 50 kg

Mounting

Assembled frame is installed on prepared foundation sized 2800x1700 mm and 200-250 mm deep, is levelled with included in the delivery set pins and reinforcement wires.

Cable channels are to laid (cable channel is allowed to be placed inside the frame). Concrete (grade not less B22,5) casting of foundation is to the upper thread bushings for turnstile fixation.

Concrete overall thickness must be min. 150 mm.

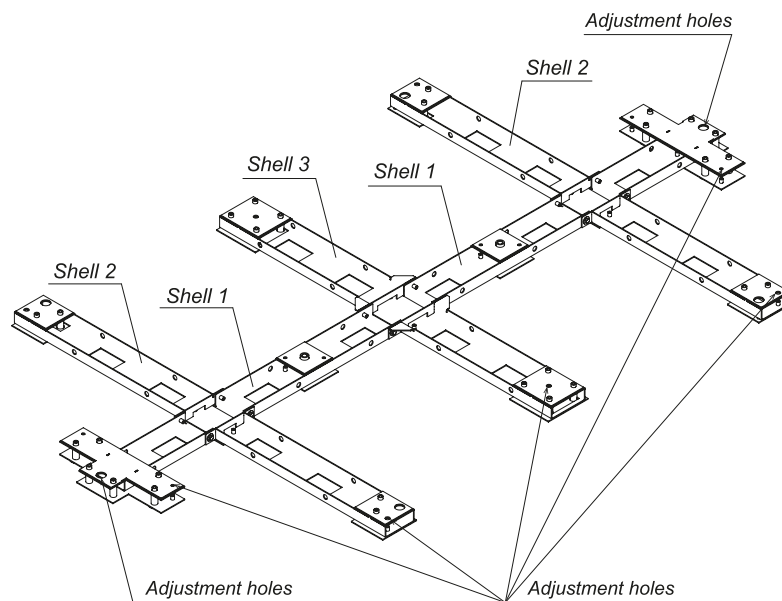

Frame assembly layout



Canopy

RTC-20 canopy is designed to be used together with the RTD-20 turnstile and to protect the turnstile from precipitations.
Several turnstiles can be installed in a row.

Delivery set

Left/right half-framework	2
Post with brackets	4
Coupling plate	1
Mounting hardware (set)	1
Operation Manual	1

Overall dimensions (length x width x height) - 2500x2420x2560 mm, Weight – max. 130 kg
Turnstile overall dimensions with canopy are defined by the canopy overall dimensions.
Canopy foundation requirements are similar to the requirements for the turnstile mounting.
The symmetry axes of the turnstile mounting holes are the same.

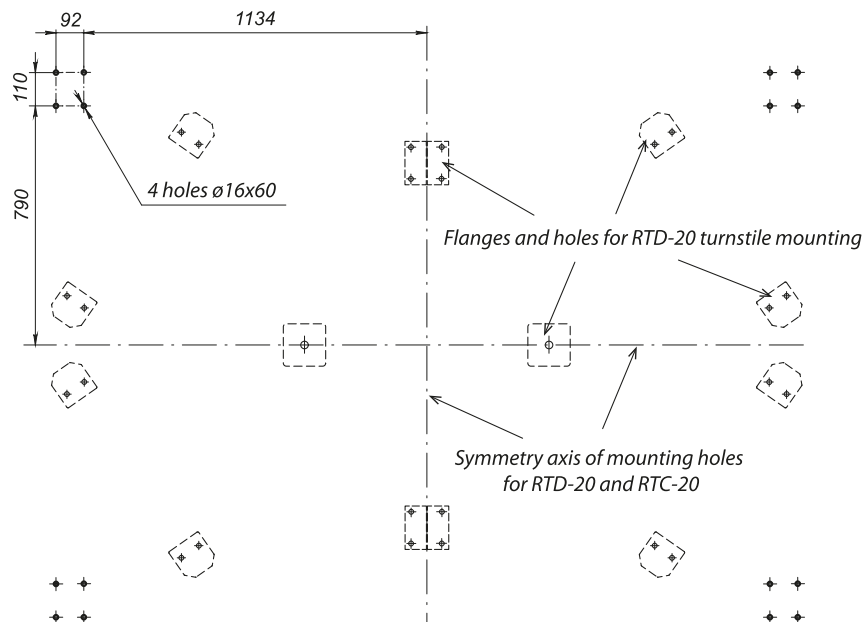

Hole marking for canopy mounting

Warranty

The warranty period is 5 (five) years commencing from the date of sale, unless otherwise determined in the delivery contract of the Product. In case of sale and installation of the equipment by authorized PERCo dealers and service centers, the warranty starts from the date of commissioning.

Should there be no date of sale on the warranty card, the warranty period shall commence from the date of manufacture specified in the Certificate and on the Product label.



WHD-16 Full height security gate

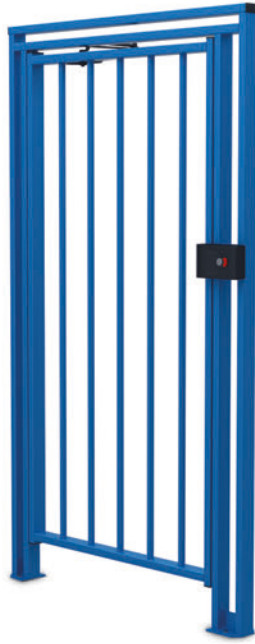

+50
-30
temperature
range

12V
operating
voltage

12
persons/min

Application

WHD-16 full height security gate with the electromechanical lock and the door latch mechanism is a blocking device designed for people flow management at checkpoints with high safety requirements and at sites where full height coverage is required.

Main features

- unlocking is performed by ACS, a key or control button located on the lock housing (the gate can be unlocked from any side)
- gate locks automatically after the swing panel is back to its home position
- lock can be unlocked remotely from ACS
- swing panel resets to its home position after the passage by means of the hydraulic door latch mechanism
- passageway width provides access for people with limited mobility accompanied by caregivers and also allows carrying bulky items
- lightweight security gate makes the passage more convenient
- high corrosion resistance provides a long service life in the adverse environmental conditions
- security gate is produced in the same design as the RTD-16 turnstile and MB-16 full height railing section
- security gate together with RTD-16 turnstiles can be used as an emergency exit
- safe voltage of the lock power supply

Operating conditions

The security gate, with regard to resistance to environmental exposure, complies with GOST 15150-69 category N2 (operation outdoors). Operation of the security gate is allowed at ambient temperature from -30°C to $+50^{\circ}\text{C}$ and relative air humidity up to 98% at $+25^{\circ}\text{C}$.

Design

Finish – galvanized powder-coated steel. Colour – blue. Powder coating to RAL colours is available on order.



Delivery set

Security gate assembly with put-on electromechanical lock	1
Door latch mechanism with fastener	1
Technical documentation (set)	1
Optional equipment (upon request)	
M10 anchor bolt with SORMAT PFG IR 10-15 anchor	4
Attaching plates and brackets required for connecting the elements of the turnstile, railing sections, canopy, security gate	

Technical specifications

Electromechanical lock voltage	from 11.5 to 14 V DC/AC
Current consumption	max. 3 A
Power consumption	max. 36 W
Throughput rate in single passage mode	12 persons / min
Daily average throughput rate in the single passage mode	2000 persons
Passage zone dimensions (HxW)	960x2000 mm
Mean time to failure	1,000,000 passages
Overall dimensions (LxWxH)	1224x350x2093 mm
Overall net weight	70 kg
Package dimensions	221x130x24 cm

Connection

When operated from ACS the lock switches to the "Open" mode and reminds so for unlimited time period after a control signal is sent to the lock. When the lock is in the locked mode, after being opened it resets to its home position.

The duration of the ACS control signal must be min. 500 ms.

Reed sensor for "Closed" mode control is recommended to be installed on the gate for proper operation of the security gate being a part of ACS.

Overall dimensions

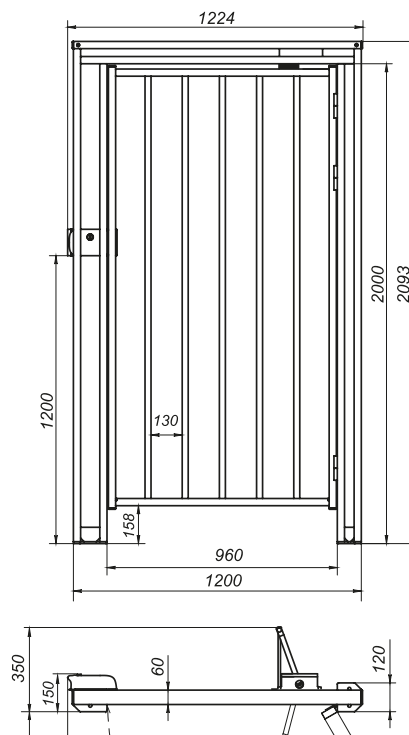

Security gate overall dimensions



WHD-16 Full height security gate

Mounting

Foundation requirements: plain concrete (grade 400 or higher), stone or similar foundations of at least 150 mm thick. For the installation of the security gate on less steady foundation it is recommended to apply reinforcing elements (250×250×400 mm).

See Fig. for security gate hole marking There is a hole for control cable laying to the lock in the security gate framework post.

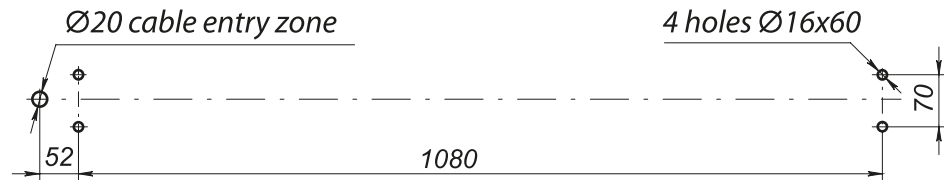

Hole marking for security gate mounting

Warranty

The warranty period is 5 (five) years commencing from the date of sale, unless otherwise determined in the delivery contract of the Product. In case of sale and installation of the equipment by authorized PERCo dealers and service centers, warranty starts from the date of commissioning.

Should there be no date of sale on the warranty card, the warranty period shall commence from the date of manufacture specified in the Certificate and on the Product label.

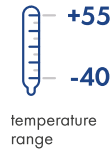
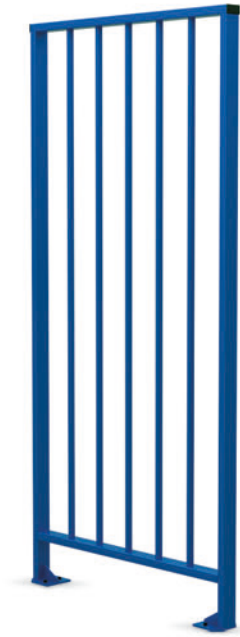

Application

MB-16 full height railing is designed to segment entrance points into functional areas ensuring security by full height coverage of the passage zone.

It can be used as a standalone blocking device and as a part of RTD-16 turnstile and WHD-16 security gate, with that, the railing is produced in the same design as above mentioned equipment so that they can form a unique construction. Sections coupling is performed at 180°, 90° angles. There are fixing elements for attaching to a wall (for more information about attaching plates and brackets required for connecting the elements of the turnstile, railing sections, canopy, swing gate see page 240).

Two versions of railings are available:

- MB-16R main railing section
- MB-16D additional railing section (the section is not fixed to the ground and is used

Operating conditions

The railing, with regard to resistance to environmental exposure, complies with GOST 15150-69 category N2 (operation outdoors). The operation of the railing is allowed at ambient temperature from -40°C to +55°C and relative air humidity up to 98% at + 25°C.

Design

Railing sections are made of galvanized powder-coated steel. Colour – blue.

Delivery set

Main railing section (MB-16R main section / MB-16D optional section)	1
Operation Manual	1
Optional equipment (upon request)	
M10 anchor bolt with SORMAT PFG IR 10-16 anchor	4
Attaching plates and brackets required for connecting the elements of the turnstile, railing sections, canopy, swing gate	



MB-16 Full height railings

Technical specifications

Overall dimensions (LxWxH)	MB-16R main section	1000x120x2093 mm
	MB-16D additional section	700* x60x2093 mm
Net weight	MB-16R main section	max. 31 kg
	MB-16D additional section	max. 9 kg
Package dimensions (LxWxH)		
Main section box		222x111x21 cm
Additional section box		208x77x14 cm

* Can be reduced to 260 mm when installing.

Overall dimensions

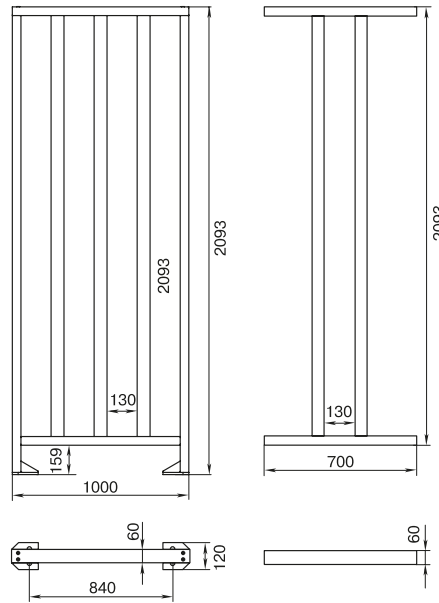

Railing sections overall dimensions

Mounting

Foundation requirements: plain concrete (grade 400 or higher), stone or similar foundations of at least 150 mm thick. For the installation of railing on a less steady foundation it is recommended to apply reinforcing elements (300x300x300 mm).

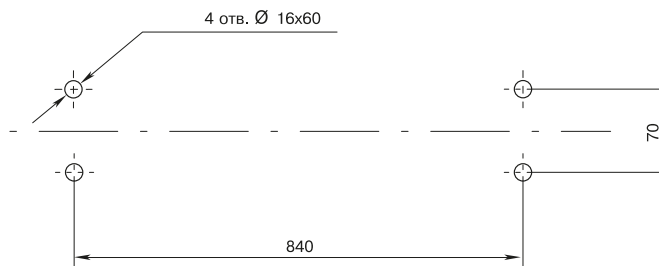

Hole marking for mounting railing sections



Passage zone modeling

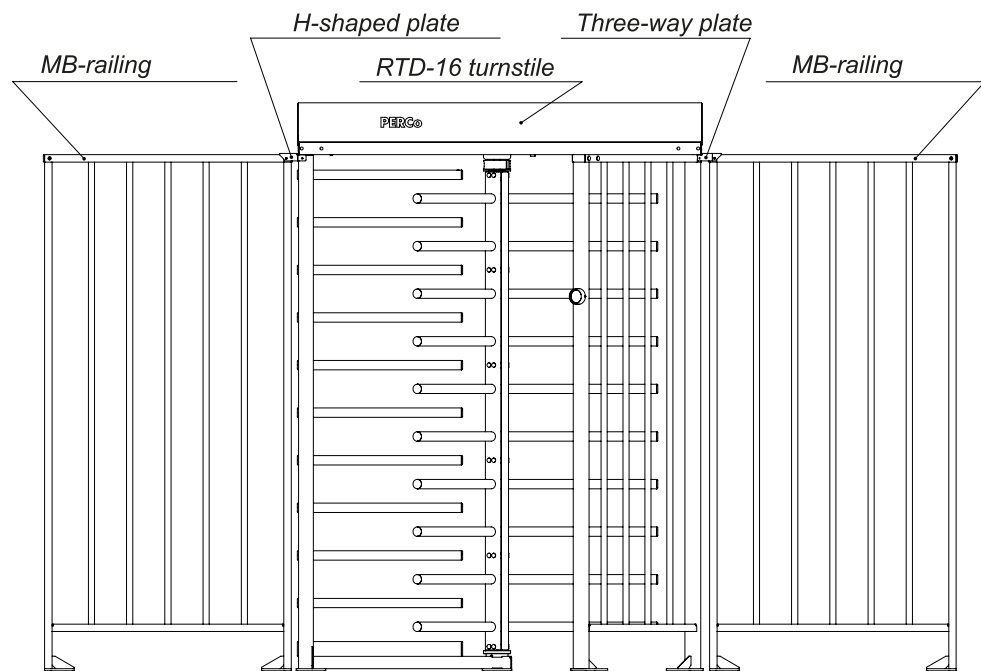

Attaching plates and brackets application

Attaching plates and brackets are required for connecting the elements of the RTD-16 turnstile, RTC-16 canopy, MB-16 railing sections, WHD-16 security gate

Nº	Item	Description	Mounting layout
1	MB-16.1	Three-way plate for coupling RTD-16 turnstile with WHD-16 or MB-16 railing section (with fastener)	Fig. 1
2	MB-16.2	Angular plate for coupling MB-16 railing sections at 90° (with fastener)	Fig. 2
3	MB-16.3	Upper straight plate for coupling MB-16 railing sections / WHD-16 security gate (with fastener)	Fig. 3
4	MB-16.4	Upper plate for coupling additional MB-16D railing sections with MB-16 section / WHD-16 security gate (with fastener)	Fig. 4
5	MB-16.5	H-shaped plate for coupling MB-16R additional railing sections with RTD-16 turnstile	Fig. 5
6	MB-16.6	T-shaped plate for attaching MB-16 railing section / WHD-16 security gate to a wall (with fastener)	Fig. 6
7	MB-16.7	T-shaped plate for attaching MB-16D additional railing section to a wall	Fig. 7
8	MB-16.8	Upper straight plate for coupling MB-16R railing section with MB-16D additional railing section	Fig. 8
9	MB-16.9	Supporting pole for MB-16R section posts	Fig. 9, 10
10	MB-16.10	Barrier plate for MB-16 railing sections and WHD-16 security gate to prevent climbing over	Fig. 11, 12



MB-16 Full height railings

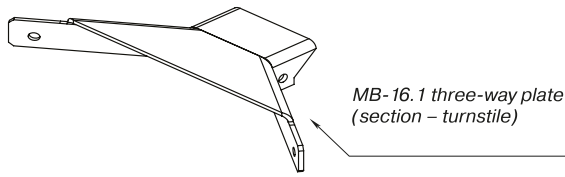

Picture 1

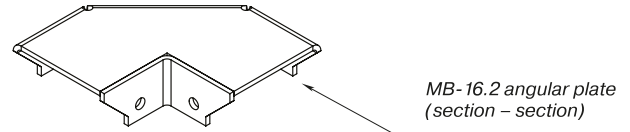

Picture 2

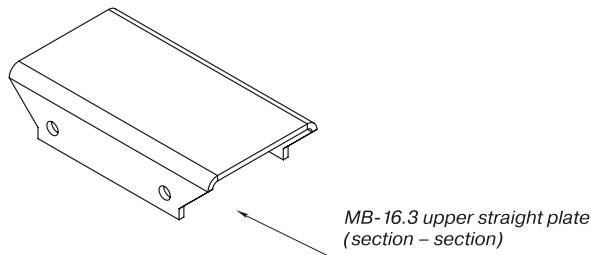

Picture 3

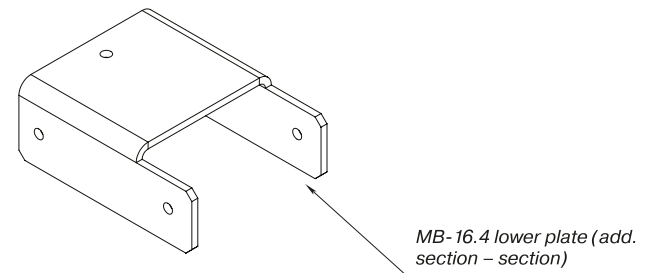

Picture 4

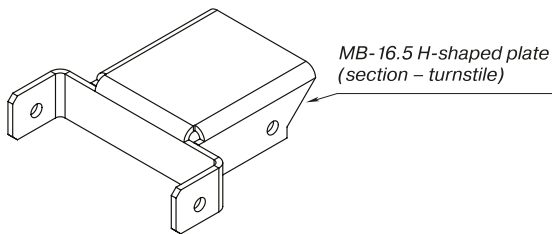

Picture 5

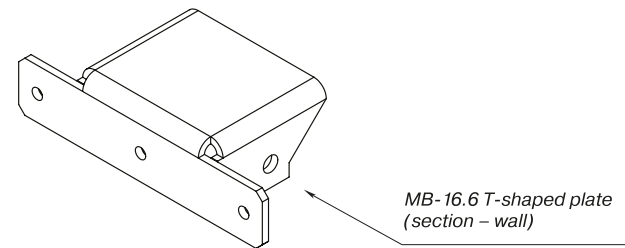

Picture 6

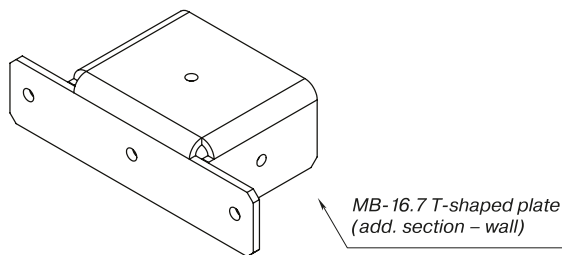

Picture 7

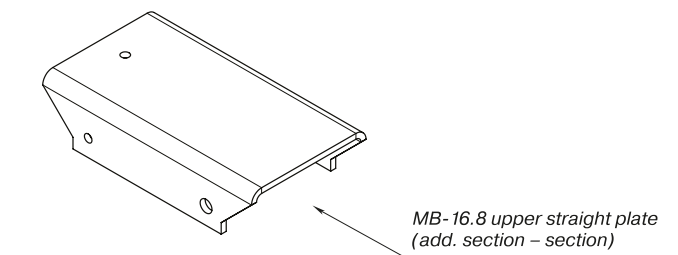

Picture 8

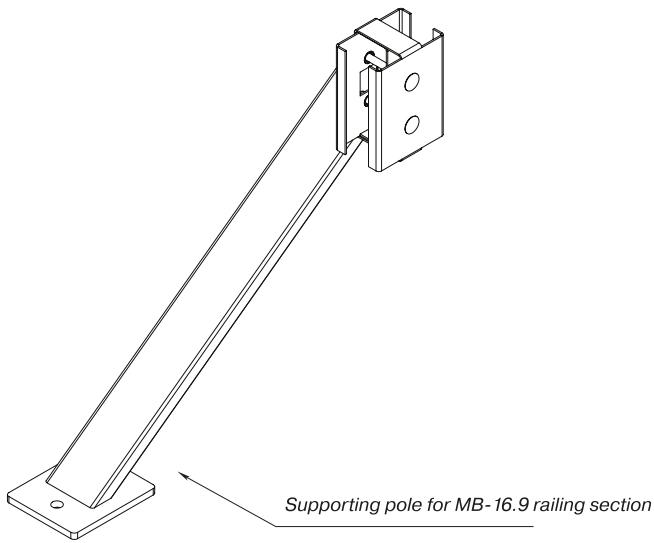

Picture 9

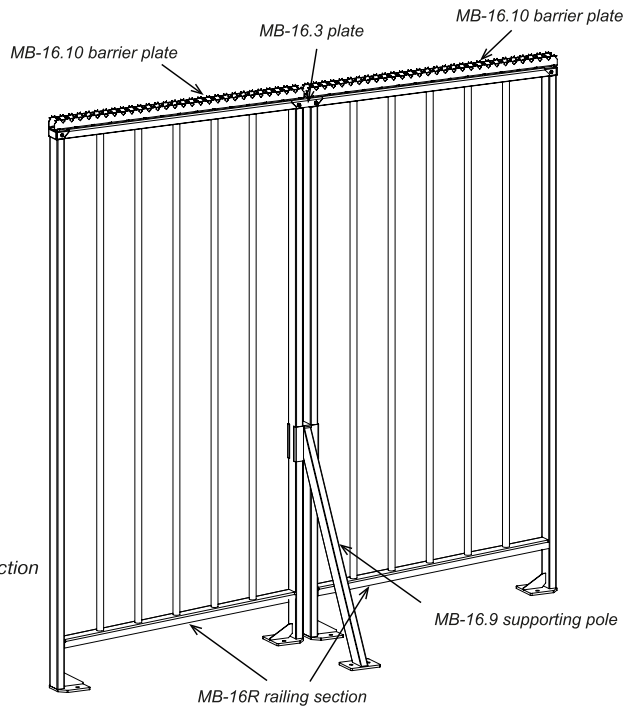

Picture 10

MB-16.9 supporting pole and MB-16.10 barrier plates mounting layout

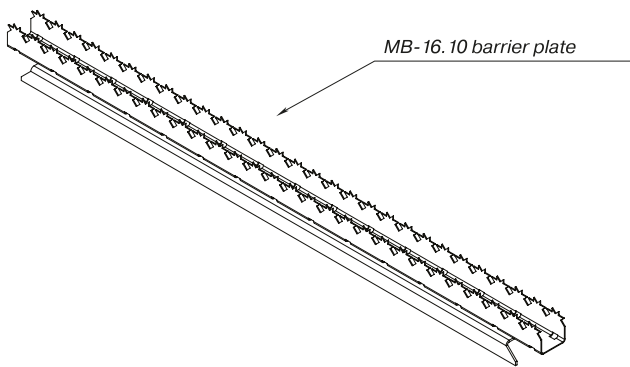

Picture 11

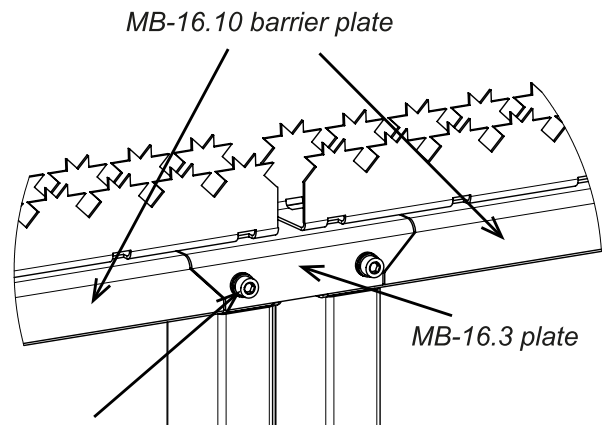

Picture 12

MB-16.10 barrier plate mounting layout

GS04 Automatic boom barrier



+55
-40
temperature range

24V
operating voltage

M
motor drive

W
120-175W
power consumption

3-6 c
opening time

100%
work intensity

7000
vehicles/day

Application

GS04 Automatic boom barrier is a blocking device designed to control access at vehicle checkpoints of enterprises, companies, parking lots, etc. It's not an anti-ram vehicle barrier.

The boom barrier is equipped with a round or rectangular-oval boom. The boom length can vary from 2.5 to 4.3 meters. The boom is fastened with a special fixer that protects the boom barrier from mechanical damage when hitting the boom. The reflective stickers ensure a safe passage.

It is recommended to install a boom barrier on sites with a traffic intensity of up to 100 percent or based on the calculation of no more than 200 vehicle passages per hour (7000 per day).



Rectangular-oval cross-section

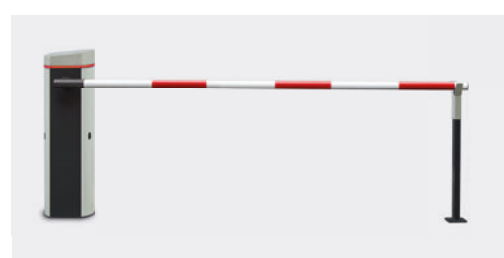

Round cross-section

Control modes

Pulse control mode – commands are pulse signals sent from different sources (RC buttons): "Open" - from one or two sources (RC buttons), "Close" - from a third source (RC button).

Potential control mode – commands are signals of constant levels and are sent: "Open" – sending a signal from one or two sources (RC buttons), "Close" command – no signal from these sources or additionally from a third source (RC button).

Single-step control mode – the "Open" and "Close" commands are pulse signals sent from one source (RC button) alternately.

For the bi-directional passage control, two different buttons are used to open and close the boom barrier, while using two traffic lights, one for each direction.



Main features

- 4 boom types are available:

Boom model	Section type	Boom length	Boom backlight
GBO3.0	rectangular-oval cross-section	3 m	PERCo-GBL3.0
GBO4.3	rectangular-oval cross-section	4.3 m	PERCo-GBL4.3
GBR3.0	round cross-section	3 m	not available
GBR4.3	round cross-section	4.3 m	not available



LED indication

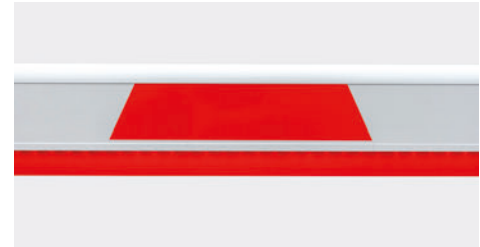

Rubber buffer pad

- The boom barrier can operate both as a standalone device and as a part of ACS, parking system, etc.
- The boom is blocked in extreme positions. If it is necessary to change the position, an emergency drive unlocking is provided to move the boom manually.
- The design provides both right-sided and left-sided boom installation.
- At a power loss, the boom remains in the same position as before.
- When an obstacle is detected, the boom changes its movement direction.
- Rubber buffer pads of the rectangular boom prevent the car from damaging upon possible hitting.
- Galvanized and powder-coated finish of the boom barrier elements ensures high corrosion resistance.
- The boom barrier is equipped with a built-in LED indication of operating modes.
- Synchronous operation of two GS04 boom barriers is provided with a Master-Slave mode.
- The boom barrier is supplied with a safe voltage of 24 V.
- The photocell built into the boom barrier housing is used as a safety sensor as well as a passage sensor.
- An optional sensor for the boom barrier opening control can be installed.
- Both 24 V and 12 V accessories can be connected to the boom barrier control board.
- The boom barrier can be equipped with additional equipment: traffic lights for two directions, a video recorder, and a siren. The additional backlight of the driving zone can be connected.
- The boom barrier can be controlled with different operating devices: both wired (button, switch, RC panel) and wireless (connection of a radio control device or GSM / BLE control module is provided).

Design

Housing – powder-coated galvanized steel; boom – aluminum profile with powder coating.

Operating conditions

The boom barrier, with regard to resistance to environmental exposure, complies with GOST 15150-69 category N1 (operation outdoors).

Operation of the boom barrier is allowed at ambient temperature from -40°C to +55°C and relative air humidity up to 98% at +25°C..

Delivery set

Boom barrier housing	1
Boom with hardware kit and stickers	1
Key to the door lock	2
Safety photocell transmitter	1

GS04 Automatic boom barrier

Technical specifications

Surge protector (LC-filter)	1	
Spare parts kit	1	
Documentation set	1	
Optional equipment (upon request)		
GBS1 support post with a boom catcher	1	
GDS1 safety photocell post	1 or 2	
GD1 optional safety photocell	1	
Power unit 24V-9A	1	
RC-panel	1	
GCR1 WRC (receiver)	1	
GCR2 WRC fob	up to 500	
GM1 mounting plate	1	
GM2 mounting channel	1	
GBF1 boom bending joint	1	
GM3 boom barrier protection rail	1	
GM4 reader post	1 or 2	
GBL LED cord for additional boom backlight	1	
Controller inductive loop	1	
Operating voltage	24 V DC	
Consumption current	max. 7 A	
Power consumption	175 W	
Boom length	2.5 - 4.3 m	
Barrier width	2.3 - 4.0 m	
Opening time	3 - 6 sec	
Work intensity	up to 100%	
Throughput rate	max. 7000 vehicles / day	
IP Code	IP54	
Electric shock protection class	III	
Mean time to failure	min. 1,000,000 passages	
Mean lifetime	min. 8 years	
Overall dimensions (length × width × height)	with lowered GBO boom	370 × 3100 (4400) × 1070
	with raised GBO boom	370 × 328 × 3810 (5110)
	with lowered GBR boom	405 × 3100 (4400) × 1070
	with raised GBR boom	405 × 328 × 3810 (5110)
Weight (net) with a boom	max. 54 kg	

Connection

The boom barrier control unit has one built-in electronic board to which a power supply, internal wiring, and optional equipment are connected. Also, on the board, there are DIP switches for setting operating modes.

Control board contacts description by connectors			
X1	1,2,3,4	+24V, GND	24VDC, 9A power supply connection of the boom barrier. Power supply connection of optional equipment
X2.1	1	GND	Common for control inputs
	2	open1/close	"Open" or "Open-close" control input in single-step mode
	3	close	"Close" control input
	4	open2	"Open" control input
	5,6	+12V, GND	+12V power output for optional equipment

X2.2	7	+12V	+12V power output for safety photocell
	8	PH1	Safety photocell control input controlling the opening
	9	PH2	Safety photocell control input controlling the closure
	10	GND	Common for control inputs
X2.3	11, 12	ALARM	ALARM siren relay output
	13, 14	LIGHT	Relay output of additional illumination of the driving zone
	15, 16	REGICTRAR	Video recorder control relay output
X3.1	1, 2	+12V, HEATER	Power outputs for heating device
X3.2	3, 4	UPS RELAY	Power control siren relay output
X3.3	5, 6, 7	NC1-C1-NO1	Relay output for traffic light control # 1
	8, 9, 10	NC2-C2-NO2	Relay output for traffic light control # 2
X3.4	11, 12	Tamper	Relay output for boom barrier housing tamper switch
X11	1, 2	+12V, GND	Boom LED backlight connection
X14	1, 2, 3	CAN H, CAN L, GND	Synchronizing bus

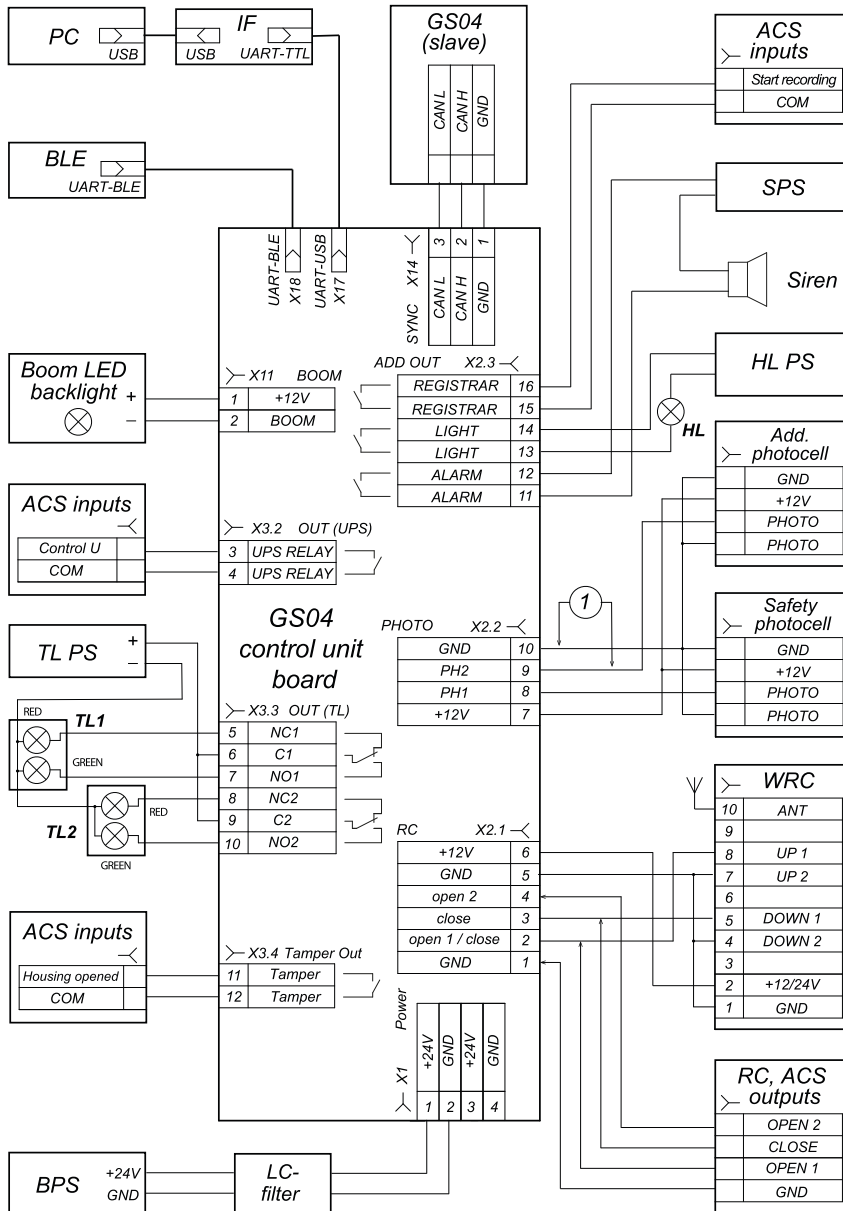

1 - wire jumper, installed in case the photocell #2 is not connected

Connection layout for GS04 and optional equipment

GS04 Boom barrier connection layout

GS04 Automatic boom barrier

Operation algorithm

The barrier can be controlled remotely from (RC-panel, button, switch), radio RC, or ACS-controller.

The boom barrier is operated by sending a low-level signal relative to GND to the open 1 / close, close, and open2 contacts.

In the pulse control mode – when a pulse is applied to the open 1 / close and open2 inputs, the boom rises, to the close input – it lowers. After a vehicle passes through the boom barrier or after the waiting time for the passage (by default - 12 seconds), the boom barrier closes automatically.

In the potential control mode – when a constant signal is applied to the open 1 / close and open2 inputs, the boom rises, and lowers to the close input. When a constant signal is removed from the open 1 / close and open2 inputs, the boom barrier closes.

In the single-step control mode – when impulse signals are applied to the open 1 / close inputs, the boom barrier is opened and closed alternately, the signals supplied to the open2 and close inputs are ignored.

Boom opening signal (open 1 / close or open2) is to be pressed for 20 seconds to set the free passage mode. After that, the boom will be permanently in the upper position until the free passage mode expires. Exit from the free passage mode is performed by sending any command to close or open the boom barrier.

The GSM / BLE control module is connected to the control board of the boom barrier over the UART-BLE interface and is designed to control the boom barrier using the GSM communication standard (call from the phone to the SIM card number in the control module), as well as to control the boom barrier, configure its parameters and receive reports on events using Bluetooth technology (using a smartphone via the PERCo application). The module can store up to 3.000 phone numbers and up to 10.000 events.

Example of connection to the ACS

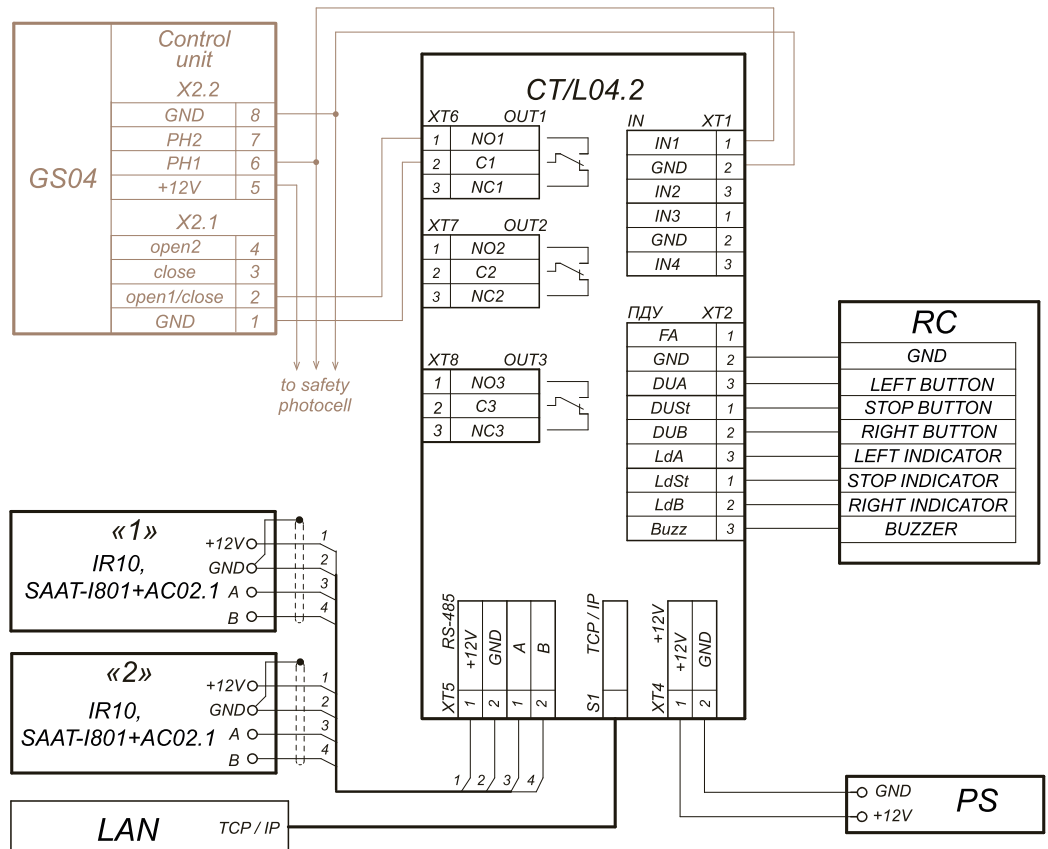

Example of the boom barrier connection to the ACS controller

Overall dimensions

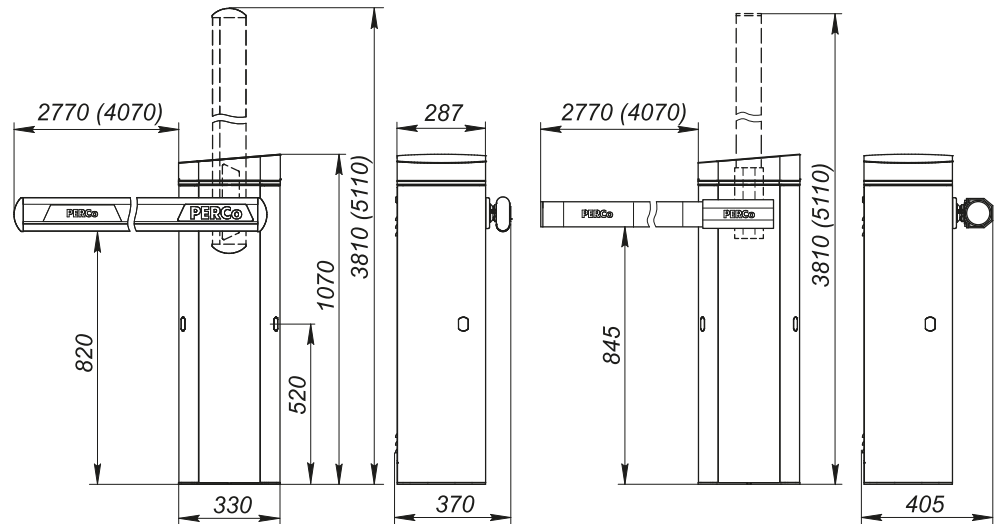

Overall dimensions

Mounting

Note

The installation of the boom barrier is a complex technical operation, which must be carried out by trained personnel in strict accordance with the product operation manual. Before operating, it is necessary to check the balancing of the boom weight with the balancing spring, as well as the presence of the MODE1 jumper on the control board when reinstalling the boom for left-sided traffic.

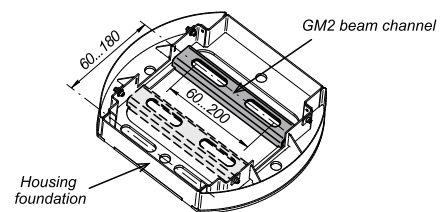
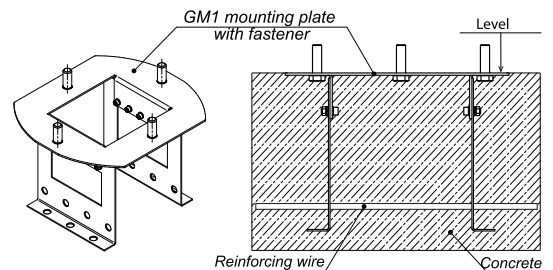
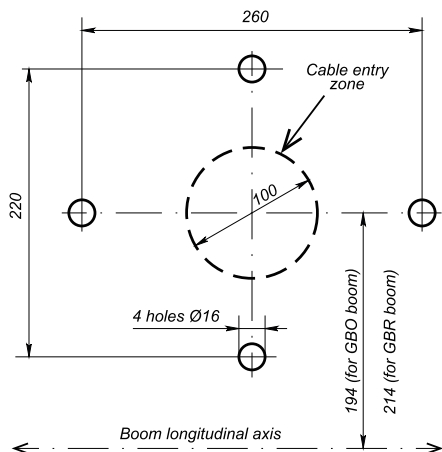

The boom barrier mounting holes marking. GM1 mounting plate. GM2 mounting channel.

GS04 Automatic boom barrier

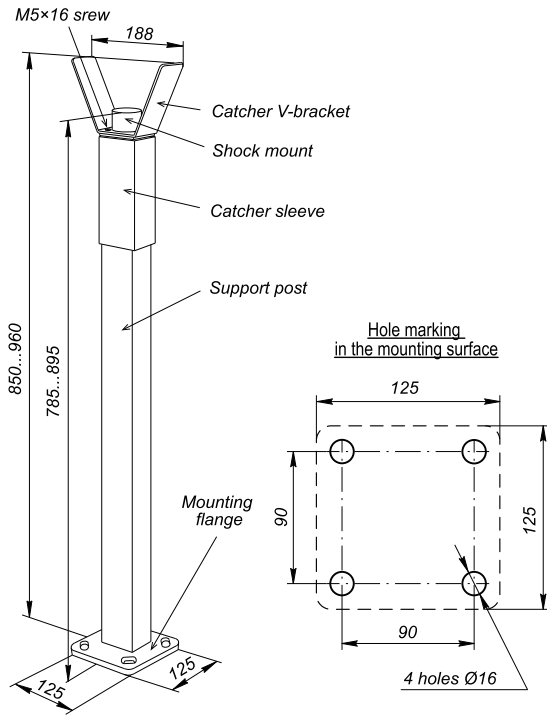

Marking of the mounting holes for the GBS1 support post

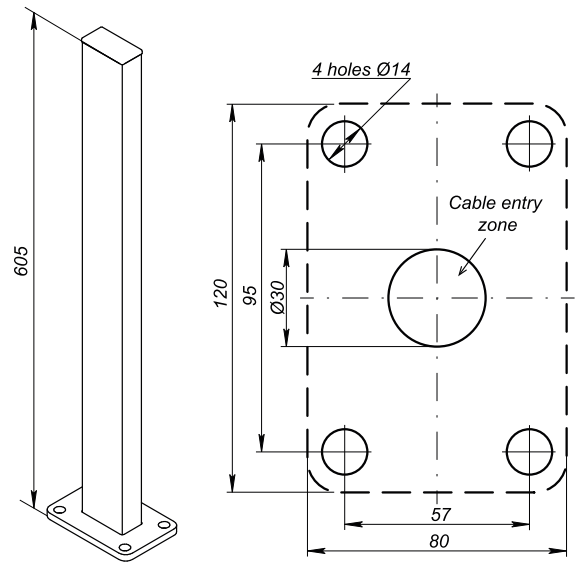

The mounting holes marking for the GDS1 safety photocell post

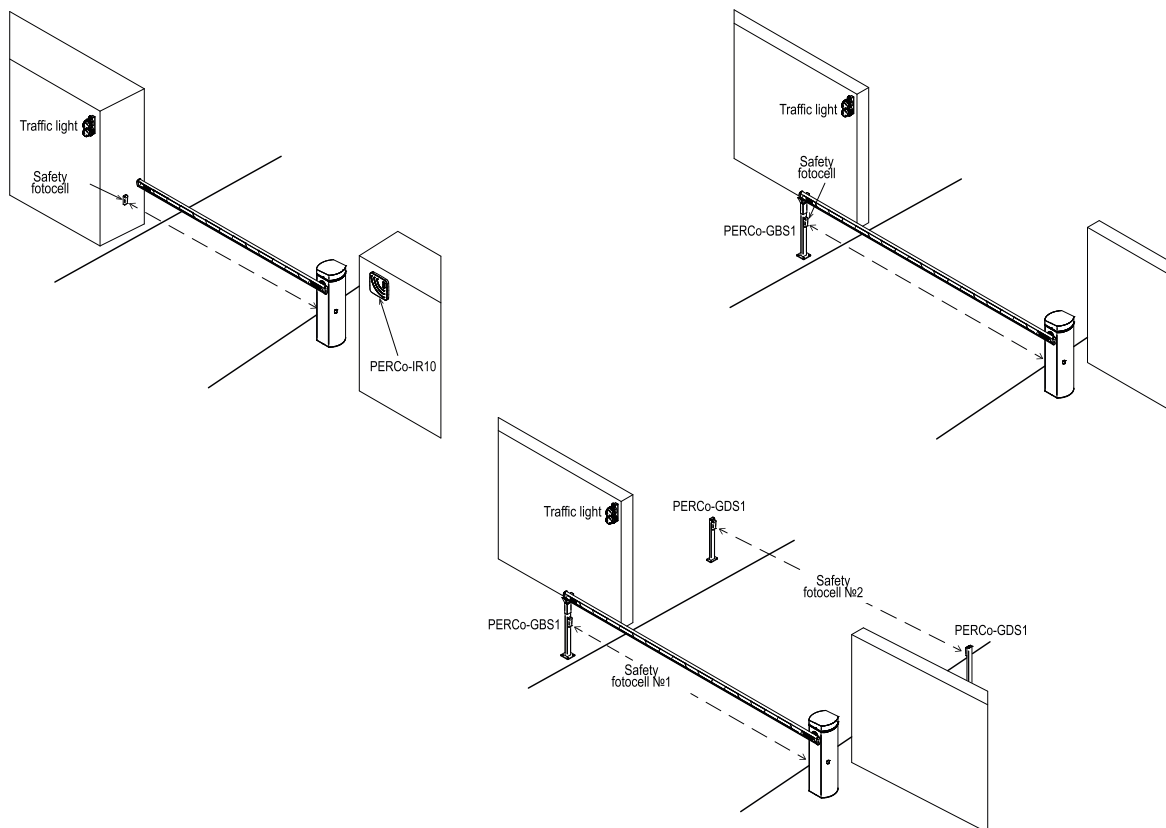

The mounting holes marking for the GDS1 safety photocell post

Warranty

The warranty period is 5 (five) years commencing from the date of sale, unless otherwise determined in the delivery contract of the Product. In case of sale and installation of the equipment by authorized PERCo dealers and service centers, the warranty starts from the date of commissioning.

Should there be no date of sale on the warranty card, the warranty period shall commence from the date of manufacture specified in the Certificate and on the Product label.



PERCo Mortise electromechanical locks

PERCo locks are electromechanical mortise locks designed for operation as part of access control systems.

PERCo produces two model series of locks: LB-and LC-series. Both of them are intended for indoor operation for doors of small and medium thickness.

The LB-series is a new product of the PERCo company, which is unique in the market. The LB-series locks are powered through contacts in the locking bolt of the LB-series locks. Power and control cables are connected through the strike plate in the door frame, not through the door leaf, which makes installation easier and provides aesthetically pleasing exterior of the door.

Locks can be installed in standard and profile doors. For thin-profile doors, special LBP locks are designed.

When installing the LC-series locks, the control cable is routed as usual - through the door leaf. The LC-series locks have two operating modes: day-time (with small bolt throw) and night-time (with enhanced bolt throw).

Differing in control mode (normally open/closed) and in center-to-center spacing, locks are presented in 6 models to be installed in standard and profile doors.

See the table below for distinctive features of PERCo locks.

Item	Power supply	Door type	Control mode	Center-to-center spacing	Type of locking bolt
LB85.3	through contact group	standard	normally closed	85 mm	flat locking bolt, with blocker roll
LB85.4	through contact group	standard	normally open	85 mm	flat locking bolt, with blocker roll
LBP85.1	through contact group	thin aluminium profile	normally closed	85 mm	flat locking bolt, with blocker roll
LBP85.2	through contact group	thin aluminium profile	normally open	85 mm	flat locking bolt, with blocker roll



How to choose a lock

Place of installation	Required type of lock	Corresponding lock models
Premises with standard safety requirements – offices, accountant departments, warehouses, staff rooms.	Normally closed electromechanical lock with potential operating mode – opens when energized. When the power is off, the lock can be unblocked mechanically with a key or thumbscrew (from inside).	LB85.3 LBP85.1
Premises with high public safety requirement – emergency, staircase and elevator exits, childcare, educational and healthcare facilities.	Normally opened electromechanical lock with potential operating mode – opens when de-energized. The lock opens in any situation (ACS controller failure, damaged cable, power loss).	LB85.4 LBP85.2



PERCo LB-series locks

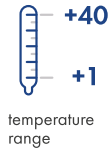

Application

The LB-series locks are electromechanical mortise locks designed for operation as operating devices in access control systems to lock light and medium-thick doors in offices and administrative buildings. The locks can be installed in wooden and non-metallic doors 38-50 mm thick.

See the table below for discrepancies of the locks:

Lock type	Control mode	Center-to-center spacing
LB85.3	Unlocks when powered (normally closed lock)	85 mm
LB85.4	Unlocks when deenergized (normally open lock)	85 mm

Main features

Main features of LB-series locks:

- the lock has a unique design that allows connecting the lock control cable through the strike plate in the door frame, not through the door leaf, which makes installation easier
- when the locks are connected to the PERCo ACS controllers (CT/L04.1, CT/L04.2, CL05.1, CL05.2, CL201.1), the lock operation can be maintained without using a door sensor (reed switch), the lock contact group registers the fact of opening / closure of the door





- mechanical release with a key
- ACS-focused design
- low power consumption
- universal lock enables its installation on both right-handed and left-handed doors
- standard center-to-center spacing (72 mm, 85 mm) allows installing locks instead of mechanical locks without the need to change or reconstruct the door
- the lock design allows using almost all types of lever handles, plates, and lock cylinders that are available in the market;
- lock is resistant to self-opening (for instance, as a result of a hard kick on the door)
- details and lock body are corrosion-resistant coated
- lock does not require preventive maintenance and lubrication from the customer for the entire period of operation

Locking and unlocking are performed upon signals from the ACS controller. Control signals are sent to the deadlock contacts through the contact group on the strike plate. After unlocking, the door can be opened by turning the handle (approximately by 20°), the bolt goes into the door frame and the door can be opened.

When the door is opened, the locking lever moves out automatically. When the door closes, the locking lever slides into the door frame and the locking bolt moves out automatically and locks the door.



Locking lever



Locking bolt moved out

Operating conditions

The lock with regard to resistance to environmental exposure complies with GOST 15150-69, category NF4 (operation in premises with climate control). Operation of the lock is allowed at ambient air temperature from +1 °C to +40 °C and at relative air humidity of 80% at +25 °C.

It is a serially produced product certified for compliance with applicable Russian and European CE standards.

Delivery set

Mortise electromechanical lock	1
Strike plate with contact group	1
Mounting kit	1
Certificate, Assembly and Operation Manual	1
Marking template (2 pcs)	1 set
Optional equipment (upon request)	
Lock cylinder with a set of keys	1
Handles with decorative plates	1 set



PERCo LB-series locks

Technical specifications

Operating voltage	12±1 V DC	
Current consumption	max. 120 mA	
Power consumption	max. 2 W	
Cylinder type	pin-typee	
Locking bolt slide out distance	min. 15 mm	
Operating mode	LB85.3	normally closed
	LB85.4	normally open
Overall dimensions	LB85.3, LB85.4	94x22x187 mm
Center-to-center spacing	LB85.3, LB85.4	85 mm
Lock weight	max. 0.5 kg	
Mean time to failure	min. 200,000	
Mean lifetime	8 years	

Connection

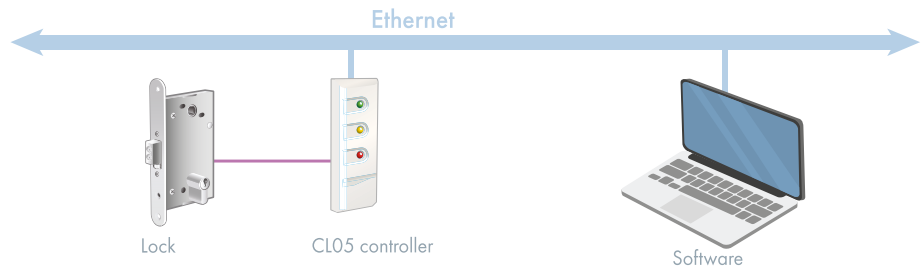

The lock is operated in potential mode. For normally closed locks unlocking is performed by sending control voltage, for normally open - removing control voltage.

To unlock the door, the ACS controller sends a control signal to the lock and holds it till the moment the door is opened (ACS controller potential operating mode).

The door opening / closure fact can be registered by the door sensor (reed switch) or by using the contact group (CT/L04.1, CT/L04.2, CL05.1, CL05.2, CL201.1 lock controller).

When the lock is connected to the ACS controller, it is recommended to install BZW06-15B or P6KE16CA or a similar suppressor on the contact group terminal block. The suppressor is designed to protect the ACS controller.

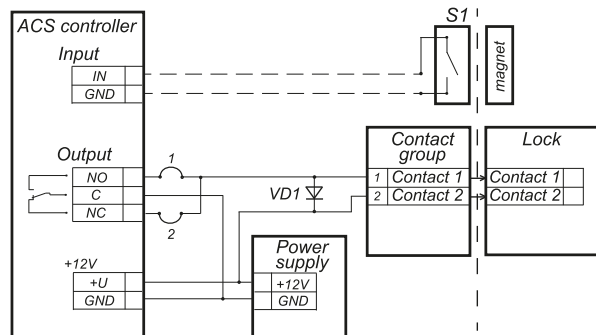

Variants of lock connections:

- 1 - lock opens automatically when powered (LB85.3)
- 2- lock opens automatically when de-energized (LB85.4)
- VD1 - 15-18 V suppressor (BZW06-15B, P6KE16CA)
- S1 - door opening detector (reed switch) can be not installed when using CT/L04.2, CL05.1, CL201.1 controllers

LB-series lock connection to the controller



Overall dimensions

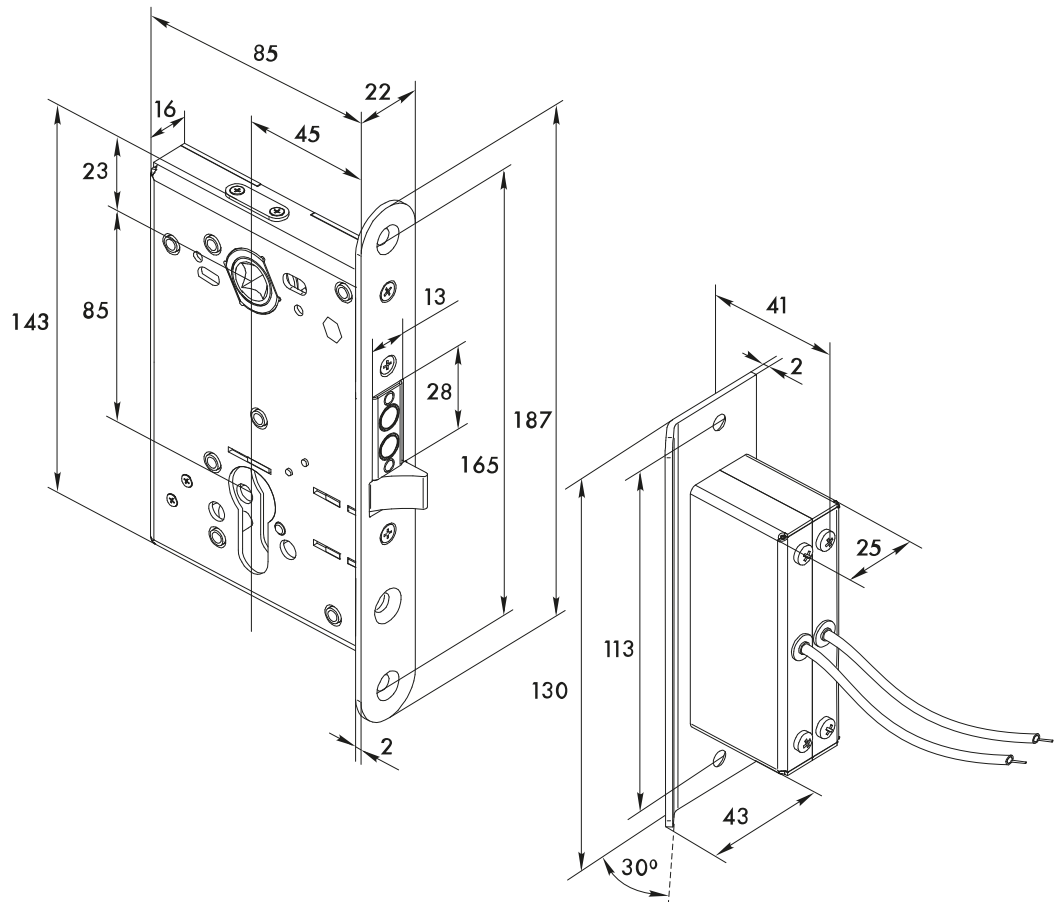

Mounting

In order to provide stable lock operation, it is necessary to ensure the accuracy of the installation of the strike plate with the terminal block relative to the locking bolt ± 3 mm vertically and ± 1 mm horizontally. The lock operates normally if the spacing between the forend plate and the strike plate is from 1 to 5.7 mm (recommended clearance of 3 mm).

The channel of the strike plate can be located symmetrically relative to cross-section of the locking bolt. The locking mechanism lever should not get into the channel of the strike plate. Otherwise, at closing the door, it can get locked with the moving lever and then it will be impossible to open the door without damaging the lock.

Upon delivery, the locking mechanism lever is oriented for installation on the left door. To install the lock on the right door, its position should be changed. For this purpose:

- remove the forend plate by unscrewing the three fixing screws
- remove the locking mechanism lever with the axle
- turn the lever 180° and lower its axis
- place the lever into place with the axle in the opposite slot
- install the forend plate and secure it with screws
- length of cylinder mechanism bolt must not exceed 50 mm

Lock design allows using standard cylinder mechanisms of European standards such as EuroDIN (V DIN 18254), or 8809, 8209, 8259 produced by ISEO (Italy), D-series mechanisms produced by Wilco Supply (254 – 274 – 294, 453, 454, 554).



PERCo LB-series locks

Warranty

The warranty period is 5 (five) years commencing from the date of sale, unless otherwise determined in the delivery contract of the Product. In case of sale and installation of the equipment by authorized PERCo dealers and service centers, the warranty starts from the date of commissioning.

Should there be no date of sale on the warranty card, the warranty period shall commence from the date of manufacture specified in the Certificate and on the Product label.



+40
+1
temperature
range

12V
operating
voltage

Application

LBP-series locks are electromechanical mortise locks designed for operation as operating devices in access control systems to lock light and medium-thick doors made of extruded aluminium.

Main features

Main features of the LBP-series locks:

- the lock has a unique design that allows connecting lock control cable through the strike plate in the door frame, not through the door leaf, which makes installation easier



- when the locks are connected to the PERCo ACS controllers (CT/L04.1, CL05.1, CL201.1), the lock operation can be maintained without using a door sensor (reed switch), the lock contact group registers the fact of opening / closure of the door
- mechanical release with a key
- ACS-focused design
- low power consumption
- universal lock design enables its installation on both right-handed and left-handed doors
- 85 mm center-to-center spacing
- the lock design allows using almost all types of lever handles, plates, and lock cylinders available in the market;
- the lock is resistant to self-opening (for instance, as a result of a hard kick on the door)
- details and lock body are corrosion-resistant coated
- the lock does not require preventive maintenance and lubrication from the customer for the entire period of operation



PERCo LBP-series locks

Locking and unlocking are performed upon signals from the ACS controller. Control signals are sent to the deadlock contacts through the contact group on the strike plate. After unlocking, the door can be opened by turning the handle (approximately by 20°), the bolt goes into the door frame and the door can be opened.

When the door is opened, the locking roller moves out automatically. When the door closes, the locking roller slides into the door frame and the locking bolt moves out automatically and locks the door.



Locking roller



Locking bolt moved out

Operating conditions

The lock with regard to resistance to environmental exposure complies with GOST 15150-69, category NF4 (operation in premises with climate control). Operation of the lock is allowed at ambient air temperature from +1 °C to +40°C and at relative air humidity of 80% at +25°C.

It is a serially produced product certified for compliance with applicable Russian and European CE standards.

Delivery set

Electromechanical mortise lock	1
Mounting kit	1 set
Certificate, Assembly and Operation Manual	1
Marking template	1 set

Strike plate is chosen by the customer when ordering

Optional equipment (upon request)	
Lock cylinder with a set of keys	1 set
Handles with decorative plates	1 set

Technical specifications

Operating voltage	12±1 V DC	
Current consumption	max. 120 mA	
Power consumption	max. 2 W	
Cylinder type	pin-typee	
Locking bolt slide out distance	min. 14 mm	
Operating mode	LBP85.1	normally closed
	LBP85.2	normally open
Overall dimensions (LxWxH)	46x25x210 mm	
Center-to-center spacing	85 mm	
Lock weight	max. 0.5 kg	
Mean time to failure	Min. 200,000	
Mean lifetime	8 years	



Connection

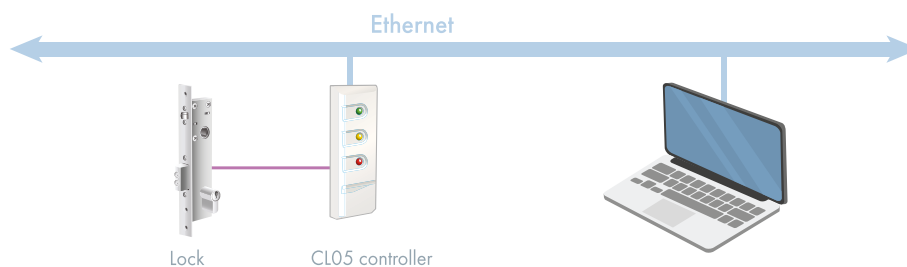

The lock is operated in potential mode. For normally closed locks unlocking is performed by sending control voltage, for normally open - removing control voltage.

To unlock the door, the ACS controller sends a control signal to the lock and holds it till the moment the door is opened (ACS controller potential operating mode).

The door opening / closure fact can be registered by the door sensor (reed switch) or by using the contact group (CT/L04.1, CL05.1, CL201.1 lock controller). Software

When the lock is connected to the ACS controller, it is recommended to install BZW06-15B or P6KE16CA or a similar suppressor on the contact group terminal block. The suppressor is designed to protect the ACS controller.

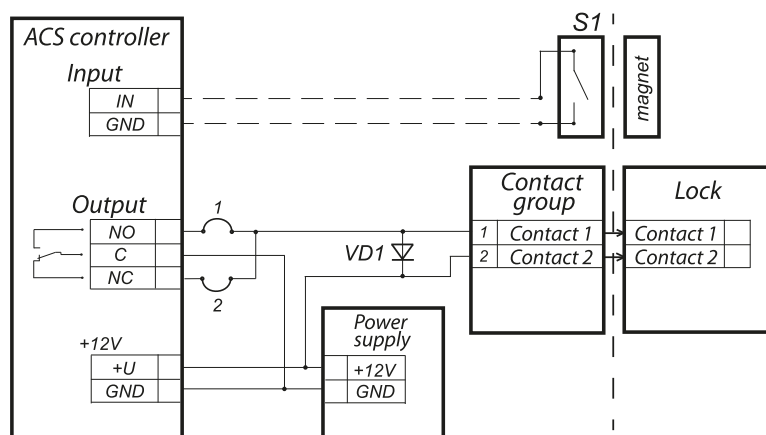

Variants of lock connections:

1 - lock opens automatically when powered (LB85.1)

2 - lock opens automatically when de-energized (LB85.2)

VD1 - 15-18 V suppressor (BZW06-15B, P6KE16CA)

S1 - door opening detector (reed switch) can be not installed when using CT/L04.1, CL201.1 controllers

LBP-series lock connection to the controller



PERCo LBP-series locks

Overall dimensions

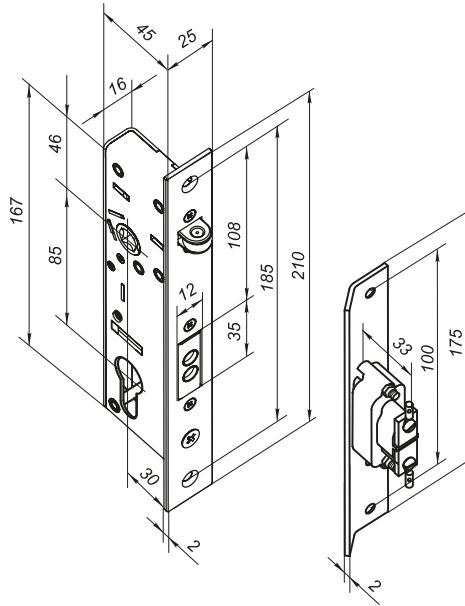

Overall dimensions

Mounting

The lock operates normally with a gap between the door frame and the door (between lock and strike plate) of 2-4 mm. The channel of the strike plate can be located symmetrically relative to the cross-section of the locking bolt.

The lock and strike plate are fixed to the profile with screws in the stack bolts made by riveters in the prepared holes. All aluminium profiles require a corresponding strike plate and mounting kit from the delivery set. Use the marking template from the delivery set for the installation of the lock and strike plate.

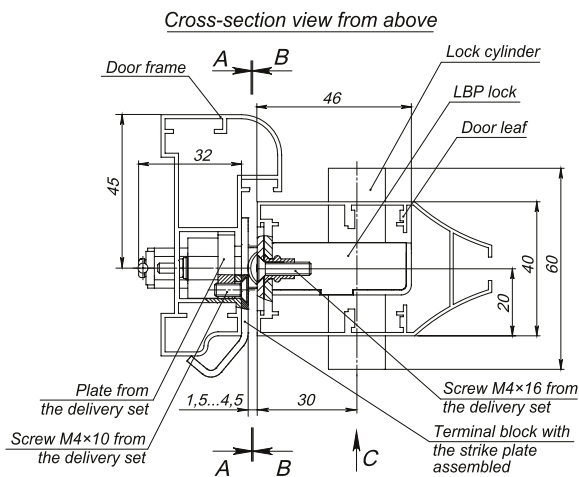

LBP85 lock with BP1 contact group assembled

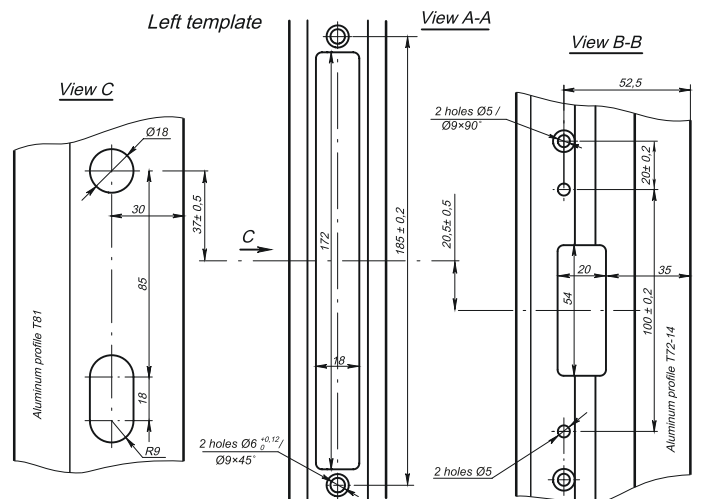

Marking template for LBP85 locks with BP1 for left door

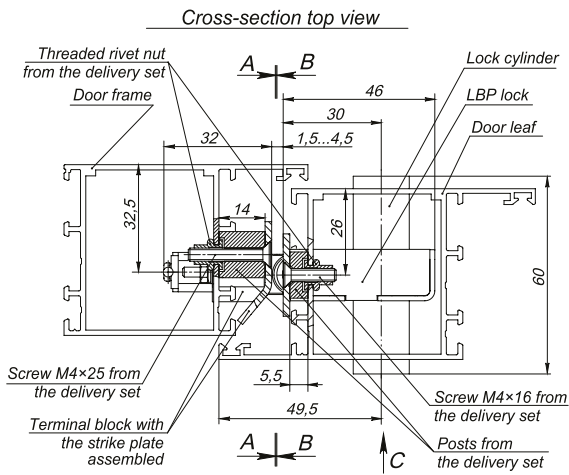

LBP85 lock with BP2 contact group assembled

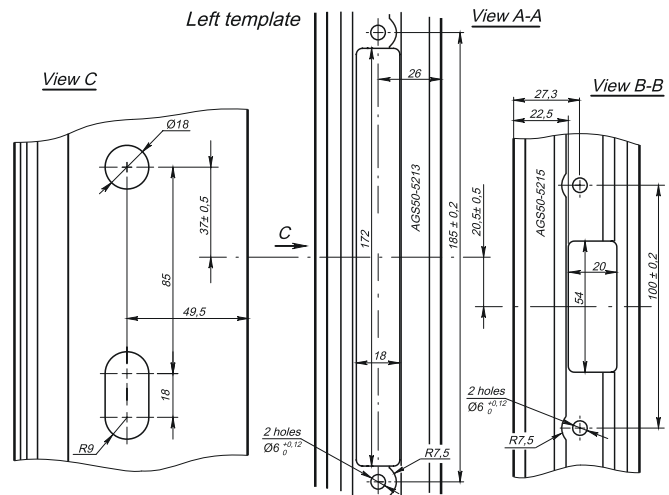

Marking template for LBP85 locks with BP2 for right door

The length of the cylinder mechanism bolt must not exceed 50 mm.

The lock design allows using cylinder mechanisms of European standards such as EuroDIN (V DIN 18254), or 8809, 8209, 8259 produced by ISEO (Italy), D-series mechanisms produced by Wilco Supply (254 – 274 – 294, 453, 454, 554).

Warranty

The warranty period is 5 (five) years commencing from the date of sale, unless otherwise determined in the delivery contract of the Product. In case of sale and installation of the equipment by authorized PERCo dealers and service centers, the warranty starts from the date of commissioning.

Should there be no date of sale on the warranty card, the warranty period shall commence from the date of manufacture specified in the Certificate and on the Product label.



PERCo headquarter

PERCo – leader in production of security systems and equipment.

PERCo in brief:

- 33-year expertise in the security market
- export to 92 countries worldwide
- PERCo trademark registered in 20 countries
- 23,000 m² of production and office space
- over 500-strong team of qualified professionals
- training center
- over 400 dealers and trade partners all over the world
- departments of sales, technical support, advertising and marketing, research and development in St. Petersburg
- modern manufacturing plant in Pskov
- warehouses in Russia and the EU (the Netherlands and Estonia)

PERCo quality management system has certificates confirming the correspondence of the products to the standards ISO 9001:2015.



PERCo manufacturing plant

33 years worldwide

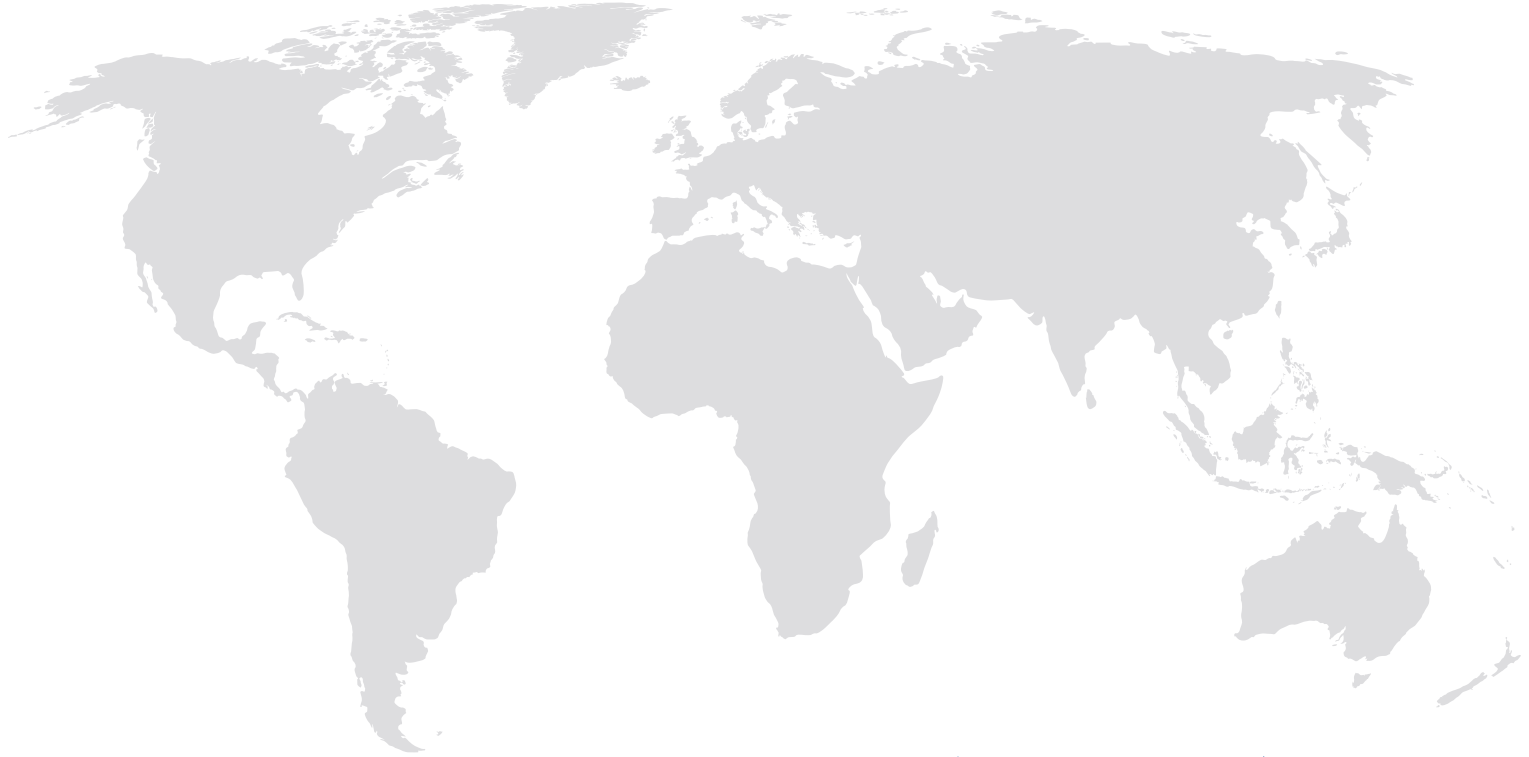

- ▶ Albania
- ▶ Armenia
- ▶ Australia
- ▶ Austria
- ▶ Azerbaijan
- ▶ Bahrain
- ▶ Bangladesh
- ▶ Belarus
- ▶ Belgium
- ▶ Benin
- ▶ Bosnia and Herzegovina
- ▶ Bulgaria
- ▶ Burkina Faso
- ▶ Cameroon
- ▶ Chile
- ▶ China
- ▶ Columbia
- ▶ Croatia
- ▶ Czech Republic
- ▶ Denmark
- ▶ Egypt
- ▶ Estonia
- ▶ Finland
- ▶ France
- ▶ Georgia
- ▶ Germany
- ▶ Ghana
- ▶ Greece
- ▶ Hungary
- ▶ Iceland
- ▶ India
- ▶ Indonesia
- ▶ Iran
- ▶ Iraq
- ▶ Ireland
- ▶ Israel
- ▶ Italy
- ▶ Japan
- ▶ Jordan
- ▶ Kazakhstan
- ▶ Kenya
- ▶ Kyrgyzstan
- ▶ Kuwait
- ▶ Latvia
- ▶ Lebanon
- ▶ Libya
- ▶ Lithuania
- ▶ Macedonia
- ▶ Malaysia
- ▶ Malta
- ▶ Mexico
- ▶ Moldova
- ▶ Mongolia
- ▶ Morocco
- ▶ Mozambique
- ▶ Netherlands
- ▶ New Zealand
- ▶ Nigeria
- ▶ Norway
- ▶ Oman
- ▶ Pakistan
- ▶ Peru
- ▶ Philippines
- ▶ Poland
- ▶ Romania
- ▶ Portugal
- ▶ Qatar
- ▶ Russia
- ▶ Rwanda
- ▶ Saudi Arabia
- ▶ Senegal
- ▶ Serbia
- ▶ Singapore
- ▶ Slovakia
- ▶ Slovenia
- ▶ South Korea
- ▶ Spain
- ▶ Sri Lanka
- ▶ Sweden
- ▶ Switzerland
- ▶ Syria
- ▶ Taiwan
- ▶ Tajikistan
- ▶ Thailand
- ▶ Turkmenistan
- ▶ Tunisia
- ▶ UAE
- ▶ Uganda
- ▶ UK
- ▶ Ukraine
- ▶ Uzbekistan
- ▶ Vietnam
- ▶ Yemen

Why choose PERCo:

- 33-year experience
- Export to 92 countries
- Modern manufacturing plant
- Wide dealership network
- Free training at the Training center



+7 (812) 247-04-64
export@perco.com
perco.com