

CONTENTS:

1	APPLICATION	1
2	TECHNICAL SPECIFICATIONS	2
3	DELIVERY SET	2
4	PRODUCT DESCRIPTION.....	3
4.1	Main features	3
4.2	Card capture reader mechanism control	3
4.3	Removal and installation of the card container	4
5	INSTALLATION.....	5
5.1	Installation instructions	5
5.2	Connection layouts of a built-in card capture reader	6
5.3	Troubleshooting	8
5.4	Card capture reader settings.....	8
5.4.1	ACS-controller configuration for working with the card capture reader in the PERCo-Web	8
5.4.2	CT/L14, CT13 configuration in Web-interface for working with the card capture reader.....	12
5.4.3	CT/L04.2, CT03.2 configuration in Web-interface for working with the card capture reader....	15
6	PERCO WARRANTY	18

1 APPLICATION

FP-01C Front panel for ST-01 Speed gate with a built-in card capture reader (hereinafter – **FP-01C** panel) is designed for installation on **ST-01** speed gate and has a built-in card capture reader for reading and withdrawing proximity cards, issued to the visitors and meant for return at exit (hereinafter – guest cards) through the speed gate.

Built-in card capture reader should work together with a proximity card reader and an ACS-controller. Card reader can be installed inside the panel, in this case reading of the card to be withdrawn will take place during insert of the card into the card capture reader slot. Card capture reader also allows to capture the cards with standard badge clips.

Card capture reader can be used as a part of **PERCo** access control systems, in this case data is transferred via RS-485 interface from a built-in reader of the card capture reader to the **PERCo** ACS-controller. Card capture reader can also work with third-party controllers, in this case, data is transferred from a built-in reader of the card capture reader to the controller via Wiegand interface.



Attention!

Product is supplied as a part of **ST-01** speed gate but to be ordered separately.

Built-in reader is **not included** in a delivery set and has to be purchased separately by the customer. Reader has to comply with the following characteristics:

overall dimensions (length × width × height)..... not more than 155×68×28 mm
 identifiers reading range

not less than 40 mm

Product is a constructional part of **ST-01** speed gate and is not supposed to be used separately.

Climatic operation conditions of the product are the same as for **ST-01** speed gate (GOST 15150-69, category U4, operation in premises with climate control). Installers should also consider operation conditions of built-in optional equipment.

Label on the inner side of housing contains product name, type, manufacture date and serial number.

Product in a standard delivery set is packed in transportation crate, which preserves its components from any damages during transportation and storage.

Overall dimensions of the transportation crate 106×22×18 cm
 Crate weight max 18 kg

Product in the original package should be transported only in closed type cargo transport units (in railroad cars, containers, closed cars, under decks, by plane, etc.). During transportation and storage, crates can be stacked no more than 6 layers high.

The storage of **FP-01C** panel in the original package is allowed indoors at ambient temperature from -40°C to +50°C and at relative air humidity up to 80% at +15°C. In the storage room should also be no acid fumes and gases, causing the corrosion.

After transportation and storage of the card capture reader at negative temperatures or high humidity, it is necessary to keep it in package within the required operation conditions for minimum 24 hours before installation.

Due to constant improvement of the products manufacturer has a right to make any modifications of the equipment, which do not make its technical specifications worse without prior notice.

2 TECHNICAL SPECIFICATIONS

DC operating voltage	21.6-28 V DC
Current consumption	min. 1.8 ¹ A
Power consumption	max. 56 W
Card container capacity	150 – 300 ²
Mean time before failure	min. 1,000,000 card captures
Mean lifetime	min. 8 years
Electric shock protection class	III (IEC 61140)
Ingress Protection Rating	IP41 (EN 60529)
Overall dimensions (L × W × H)	140×180×987 mm
Weight (net)	max. 7 kg

3 DELIVERY SET

FP-01C panel	1
Key from the card container lock	2
Certificate & Operation manual	1
Transportation box	1

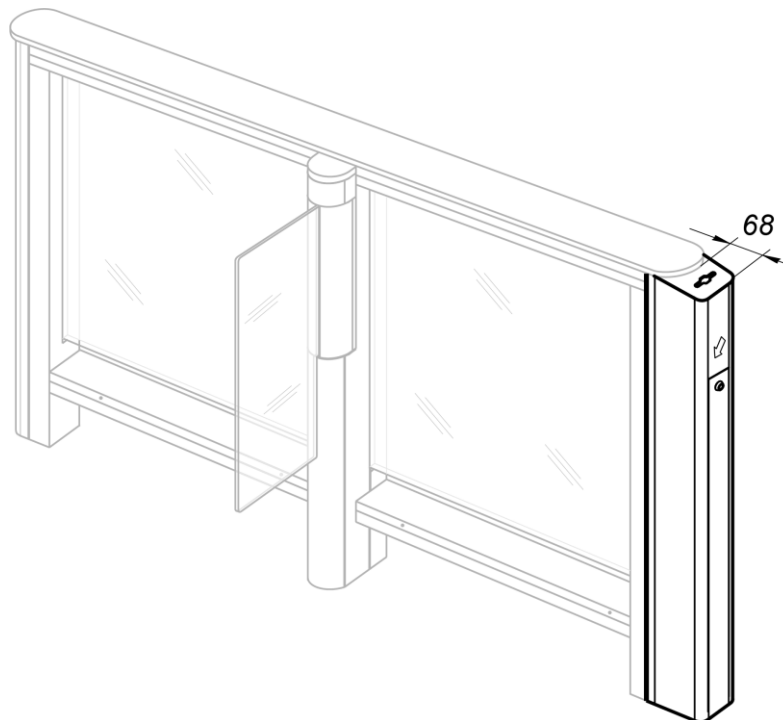

Figure 1. *ST-01* Section with installed *FP-01C* panel

¹ Built-in card capture reader power supply is provided either by a separate power supply 24VDC-2A or **ST-01** turnstile power supply (in this case, the power supply should provide general absorbed current not less than 8A during 10 seconds).

² Depending on the card thickness (2 mm or 0.9 mm).

4 PRODUCT DESCRIPTION

4.1 Main features

- In the front panel of the card capture reader there is a container with a lock for card collection.
- Card reader (to be purchased separately) can be built in the panel, it should be installed inside at the upper part of the card capture reader panel using the double-sided tape. In this case the identifier is read from the proximity card that is inserted in the slot of the card capture reader.
- The slot for card withdrawal has a built-in LED backlight.
- The slot for card withdrawal has a form that allows the card capture reader to withdraw cards with the standard clips for badges.
- The slot for card acceptance is equipped with a protective shutter, preventing the ingress of foreign objects into the container as well as cards that are not subject for withdrawal.
- The card capture reader features optical sensors allowing to correctly record the fact of capture of proximity cards, as well as the filling of the container of the card capture reader.
- The card capture reader is supplied with the safe voltage – no more than 28 V.
- The card capture reader has low power consumption – no more than 56 W.

4.2 Card capture reader mechanism control

Card capture reader mechanism operation algorithm:

1. In a standby mode of proximity card presentation, the card capture reader slot is always backlit by the built-in LED indicator. Built-in speed gate reader reads the proximity card identifier and sends the signal to the ACS external controller for analyzing.
2. If the presented proximity card belongs to an employee and shouldn't be withdrawn, in this case the ACS-controller allows the passage through the turnstile in the specified direction (sends the signal to the turnstile control mechanism). The shutter which blocks the access to the card capture container remains closed preventing the accidental card withdrawal. The card slot backlight remains constant.
3. If the presented card is a temporary visitor's card and should be withdrawn, then the ACS-controller sends the signal to the card capture reader control board input "Capture card" (INPUT **XT1**, see Fig. 2). The card slot backlight will switch to the flashing mode of 2 times per second indicating that the card should be withdrawn.
4. If after receiving the signal the optical sensor in the card capture reader detects presence of a card in the slot, then the solenoid opens the shutter that blocks access inside the card reader and the card falls into the container – thus the withdrawal procedure is finished. If the optical sensor doesn't detect the presence of a card in the slot, then the card slot remains blocked.
5. The second optical sensor registers the fact of withdrawal when you drop the card into the container. In this case, the "Card captured" control signal is sent from the output of the control board of the card capture reader to the ACS-controller and serves as a confirmation of the withdrawal of the card and activates the passage permission. Upon receiving the signal, the ACS-controller permits the passage in a specified direction and deactivates the "Capture card" signal from the input of the control board of the card capture reader.
6. The third optical sensor monitors overflow of the container with cards. When a container is overfilled, the card capture reader sends the "Alarm" signal to the ACS-controller (**XT2** Alarm output, Fig. 2); 2 seconds on / 2 seconds off indication warns the operator that it is necessary to empty container from cards. The card capture reader operation will be blocked after it receives another 9 cards if the container is not emptied. Unblocking of the card capture reader and deactivation of the "Alarm" signal will occur automatically when the container is emptied from cards (see Sect. 4.3). Also, the "Alarm" signal is sent to the ACS-controller in case the card capture reader is broken.



Note:

Blocking temporary card withdrawal does not impact the card capture reader functioning on employees' permanent cards and visitors' cards which should not be withdrawn.

Parameters of control signals:

"Capture card" *INPUT* is controlled by the output of the ACS-controller, "dry contact" or "open collector" type. The input is "normally opened", i.e. activation of the input will be done by a control signal the ACS-controller couples to the *GND* (contact 4).

Parameters of input:

- the voltage at the open contact regarding *GND* 5 ± 0.5 V
- the voltage at the closed contact in regarding *GND* not more than 0.8 V
- current through the closed contact not more than 1.5 A

"Card captured" and "Alarm" outputs – "dry contact" type. Each of these outputs represent one of the relay contacts. The other contacts of both relays are combined together for "COM" output (contact 7). The outputs are "normally opened", i.e., the activation of each output will be its closure with the COM contact.

Parameters of outputs:

- the maximum voltage between the correspondent output and contact COM 42 V
- the maximum switching current 200 V

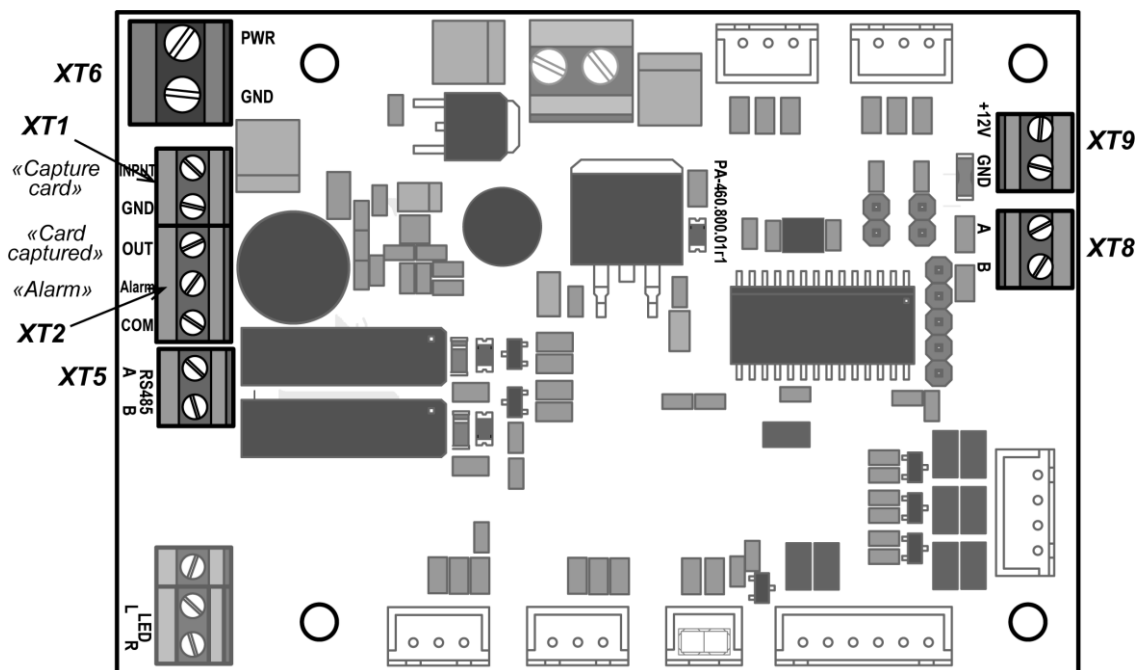

Figure 2. Card capture reader control board

Card capture reader control board layout is shown in the Fig. 2. There are terminal blocks on the board:

- **XT1** – input of the card capture reader (INPUT and GND contacts).
- **XT2** – outputs of the card capture reader "Card captured" (OUT and COM contacts) and "Alarm" (Alarm and COM contacts).
- **XT5** – connector with RS-485 interface for wiring from the ACS-controller (A and B contacts, **PERCo** controllers only).
- **XT6** – connector for connection of the power supply of the card capture reader (PWR and GND contacts).
- **XT8** – connector for connecting the **PERCo** reader of the card capture reader to the lines with RS-485 interface (A and B contacts).
- **XT9** – connection for the power supply of the reader of the card capture reader (+12V and GND contacts).

4.3 Removal and installation of the card container

To take out the card container from the card capture reader, unlock the container lock, then by pulling the key towards you, take out the container.

Installation of the container into the card capture reader should be done in reverse order.

5 INSTALLATION

5.1 Installation instructions



Attention!

The **ST-01** speed gate installation instructions – see in the **ST-01 Operation Manual**. Take into consideration that overall length of the speed gate with the **FP-01C** panel installed increases by 68 mm (see Fig. 1).

FP-01C panel should be installed on the **ST-01** speed gate instead of the standard front panel (see Fig. 1 and **ST-01 Operation Manual**, Sect. 8.9.2). Before mounting (removing) the panel it is necessary to remove the glass cover from the turnstile (see **ST-01 Operation Manual**, Sect. 8.9.6).

FP-01C panel arrangement is shown in the Fig. 3. Then the position numbers are arranged according to the Fig. 3.

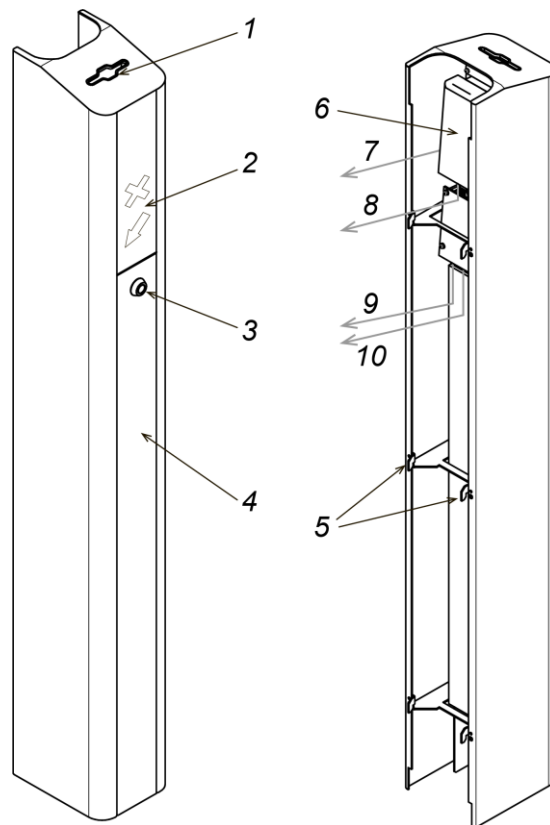

Figure 3. FP-01C Front panel

1 – card slot; 2 – front end indication module; 3 – container lock;
4 – container; 5 – panel fixing hooks; 6 – built-in reader¹

7 – connection cable of module with indicators¹; 8 – cable for connecting the reader¹;

9 – power supply cable for the card capture reader¹; 10 – control cable for the card capture reader¹

1. Unpack the panel. Install the built-in reader inside the panel, if needed. The installation location is shown in the Fig. 3. To install the reader, use the double-sided tape.



Attention!

Proximity card reader is **not included** in the delivery set!

It is possible to install not only **PERCo** readers (**IR13, IR19, IR03.1, MR07 OEM, RP-15.2**), but also third-party ones.

Reader should comply with the following technical requirements:

- overall dimensions (length - width - height) not more than 155×68×28 mm
- identifiers reading range not more than 40 mm.

¹ Not included in the delivery set.

2. Lead the connection cables to the speed gate, connect, and place the connection cables:
 - to the speed gate indication control module – cable for the indication front module (7)¹,
 - to the power supply 24VDC – power supply cable for the card capture reader (9)²,
 - to the ACS-controller – cable for the built-in reader and control cable for the card capture reader (10).
3. Install the **FP-01C** panel on the **ST-01** speed gate by using the fixing hooks (5).
4. Install back the speed gate glass cover.

5.2 Connection layouts of a built-in card capture reader

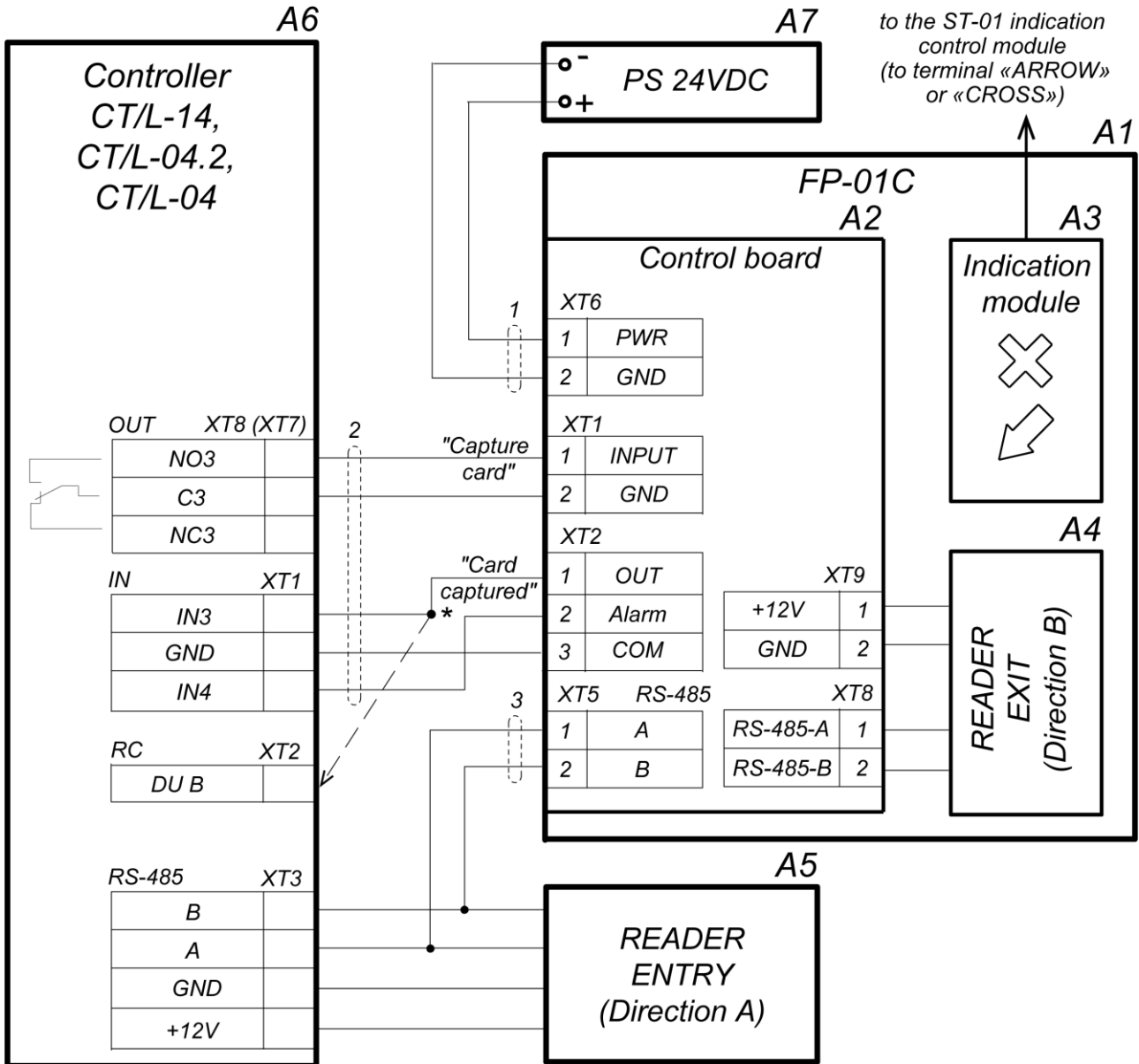

* If all additional inputs of the controller are occupied, then the "Card captured" output of the card capture reader is connected in parallel with the RC-panel to the control input of the controller DU B (or DU A, depending on the direction of passage).

Figure 4. Diagram for connecting the card capture reader to the PERCo ACS-controllers via RS-485 (list of components mentioned in the Table 1)

¹ For the white arrow indication on the front panel the connection cable should be connected to the **ARROW** terminal, for the red – to the **CROSS** terminal (see Sect. 8.9.2 *ST-01 Operation manual*).

² In function of power supply, it's possible to use the **ST-01** gate power supply (contacts 1 and 2, **X1** terminal, ST-01.771 control board or any of ST-01.761) which can provide the current not less than 8A during 10 seconds.

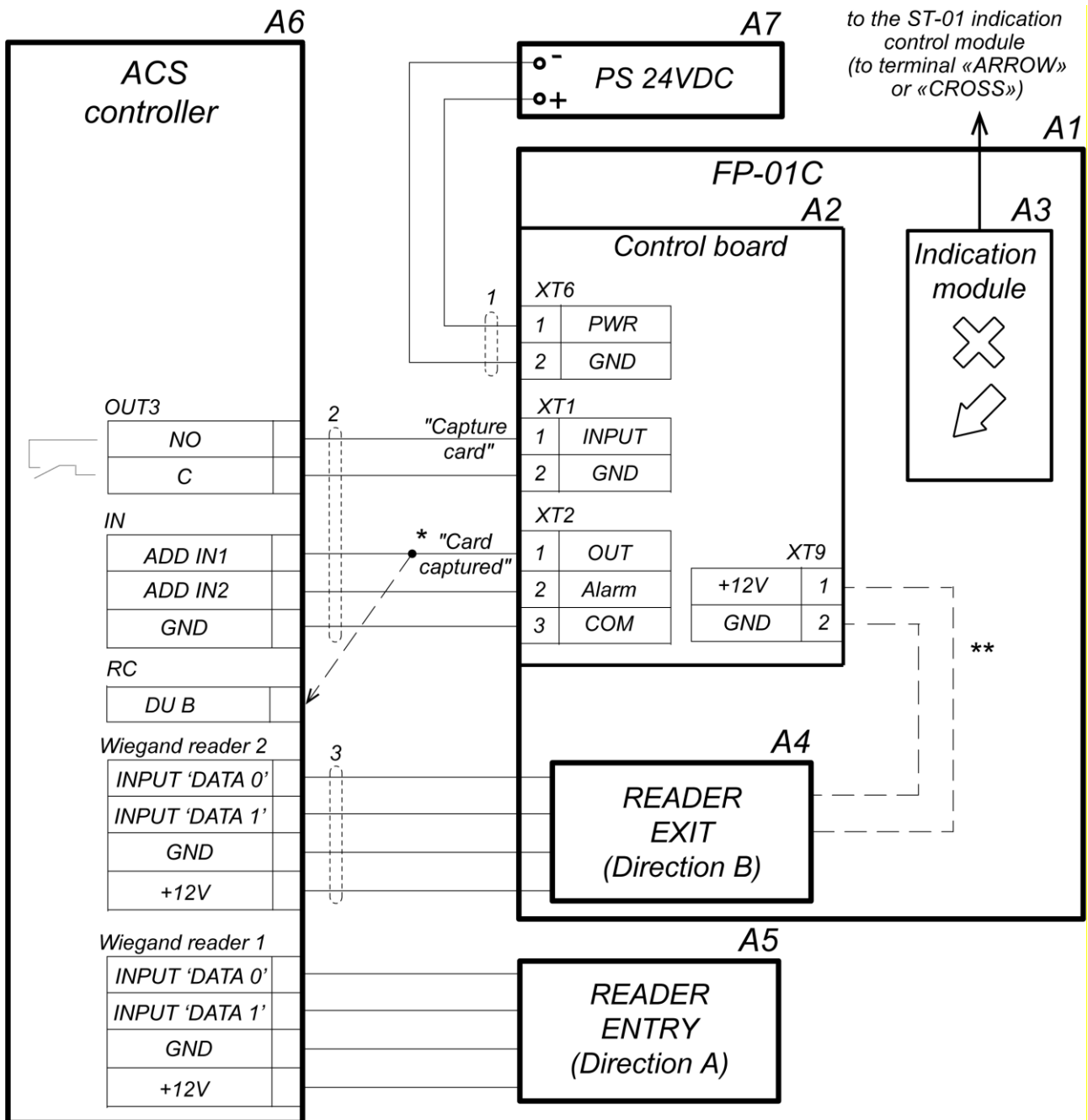

* If all additional inputs of the controller are occupied, then the "Card captured" output of the card capture reader is connected in parallel with the RC-panel to the control input of the controller DU B (or DU A, depending on the direction of passage).

** The reader can be powered from the control board.

Figure 5. Diagram for connecting the card capture reader to the ACS-controller via Wiegand interface (list of components mentioned in the Table 1)

Table 1. List of components of card capture reader connection layouts

Legend	Item	Qty
A1	FP-01C Front panel	1
A2	Card capture reader control board	1
A3	Front end indication module	1
A4*	Reader installed in a card capture reader (direction B)	1
A5*	Reader (direction A)	1
A6*	ACS-controller	1
A7*	Power supply 24 VDC/2.5A	1
1*	Power cable for the card capture reader	1
2*	Cable for connecting the ACS-controller	1
3*	Cable for connecting the reader installed in a card capture reader	1

* equipment is not included in the standard delivery set.

5.3 Troubleshooting

Possible faults to be corrected by the customers themselves are listed in Table 2.

For faults not listed in Table 2 we advise to consult PERCo Technical Support Department.

Table 2. Possible failures and troubleshooting

Fault	Probable cause	Remedy
Power supplies are on, the card capture reader does not function, the slot is not backlit.	Faulty connection or breakdown of power supply cable (9). Faulty power supply unit.	Replace the cable of the card capture reader (9). Replace the power supply unit.
The LED indicators are on but the card capture reader is not controlled by the ACS-controller.	Faulty connection or breakdown of control cable (8) of the card capture reader (10).	Replace the control cable of the card capture reader (10).

5.4 Card capture reader settings

5.4.1 ACS-controller configuration for working with the card capture reader in the PERCo-Web



Attention!

- Only controller parameter settings which are connected with card capture reader operation are described in Appendix.
- Visitors' cards that should be withdrawn, must be set to obligatory verification process upon presentation to the reader in the direction controlled by the card capture reader.

1. Log into the system by using a Web browser (see *PERCo-Web Administrator's manual*).
2. Go to "**Administration**" → "**Configuration**" section by using the navigation bar.
3. On the page working area select the main controller that is physically connected to the card capture reader:

The screenshot shows the PERCo-Web Administration interface. The top navigation bar includes 'Administration', 'PERCo-Web', 'Help', 'admin', and 'Exit'. Below this, there are tabs for 'Configuration', 'System events', 'Tasks', 'Operators', 'Roles and permissions', and 'Licenses'. The 'Configuration' tab is active, displaying a tree view of system components. Under 'Turnstile controller CT/L04.2 (172.17.17.127)', there is a sub-entry for 'Turnstile controller №1 (172.17.17.127)' with status indicators (green, yellow, red) and a lock icon. On the right side, there is a summary of device status: 'All devices: 1', 'Working: 1', 'With errors: 0', 'Deactivated: 0', and 'Commands' queue: 0'.

4. Click  **"Edit"** button on the page toolbar. The **"Device properties"** window will be opened.
5. In the opened window select **"Additional outputs"** tab.
6. In the window working area, select **"Additional output No..."** (number of the output must match the controller output that is physically connected to *"Capture card"* input of the card capture reader).
7. Specify the following parameters by using the drop-down list on the window working area:
 - set **"Standard"** value for **"Type"** parameter;
 - set **"Not energized"** value for the **"Normal state"** parameter:

Device properties ✕

Device name:

Device type: **Turnstile controller CT/L04.2**

General
Additional inputs
Additional outputs
Status
External connections

Additional output № 3

Additional output № 4

Additional output No.5

Additional output No.6

Additional output № 3

Type

Normal state

Output operation instructions

Normalize

Activate

All in the device(s) ▼

Save

Save and close

8. Switch to **"Additional inputs"** tab.
9. If the card capture reader acts as an external verification device for the controller ("Card captured" signal is sent to a separate input of the controller), then select **"Additional input No..."** (number of controller input that is physically connected to the *"Card captured"* output of the card capture reader) and set the following parameters by using the drop-down menu:
 - set **"Confirmation from external verification device"** value for the **"Type"** parameter;
 - set **"Disconnected"** value for the **"Normal state of the contact"** parameter;
 - set **"Device ... direction ..."** value for the **"Device number"** parameter (the number of OD and direction number must match those that are controlled by the card capture reader):

Device properties ✕

Device name:

Device type: **Turnstile controller CT/L04.2**

General
Additional inputs
Additional outputs
Status
External connections

Additional input No.3

Additional input No.4

Additional input No.5

Additional input No.6

Additional input No.3

Type

Normal condition of the contact

Device number

All in the device(s) ▼

Save

Save and close

10. If necessary, configure the system response to the "Fault" signal sent by the card capture reader. To do this: select "**Additional input No...**" (number of the input must match the input of the controller that is physically connected to the "Fault" output of the card capture reader) and set the following parameters by using the drop-down menu:

- set "**Standard**" value for "**Type**" parameter,
- set "**Disconnected**" value for the "**Normal condition of the contact**" parameter:

- configure controller response to the activation of the input No.5 by using the activation or normalization output parameters of the, for example, the activation of an additional output of the controller No.5 that is connected to the alarm system:

11. Click "**Save and close**" button. The "**Device properties**" window will be closed.

12. Within the main controller, select the controller of the OD which is controlled by a card capture reader:

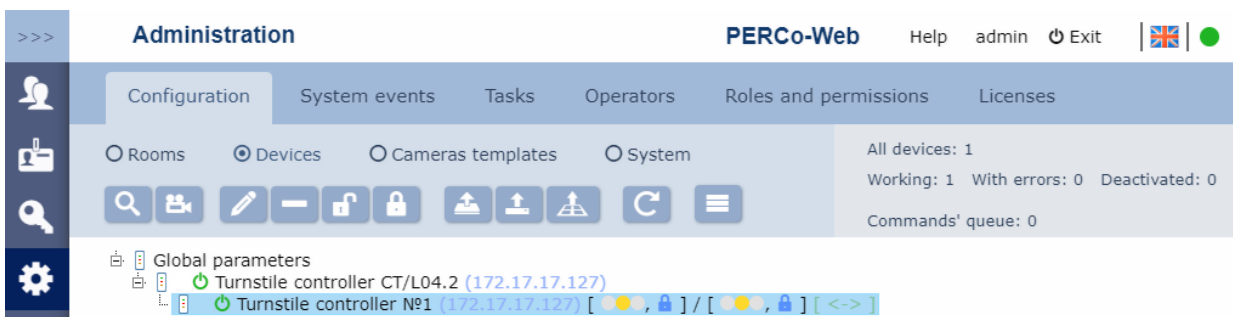

13. Click  "Edit" button on the page toolbar. The "Device properties" window will be opened.
14. Switch to "Reader No..." tab (number of the reader must match the reader, which is controlled by the card capture reader).
15. The "Card captured" signal sent by the card capture reader is considered as a confirmation of withdrawal of the card. To configure the confirmation parameters, select the group of "Verification" parameters and set the following values:
- for "Verification" parameter:
 - set "External verification device" value, if the card reader acts as an external verification device for a controller ("Card captured" signal is sent to a separate input of the controller),
 - set "Remote control" value, if the "Card captured" output of the card capture reader is connected to the controller in parallel with the RC. In this case, it is also necessary to check "In "Control" mode" box on the left side of the "Remote control permission" window:
 - Check boxes of the "Verify VISITORS IDs from the external verification devices" parameter (or, respectively, "...from the remote control"):
 - "When passing";
 - "When passing with VIOLATED TIMING";
 - "When passing with ZONALITY VIOLATION".
 - specify the desired value for the "Waiting period for verification confirmation from the external verification device" parameter (or, respectively, "...from the remote control") which will be used by the controller for waiting of a "Card captured" signal.

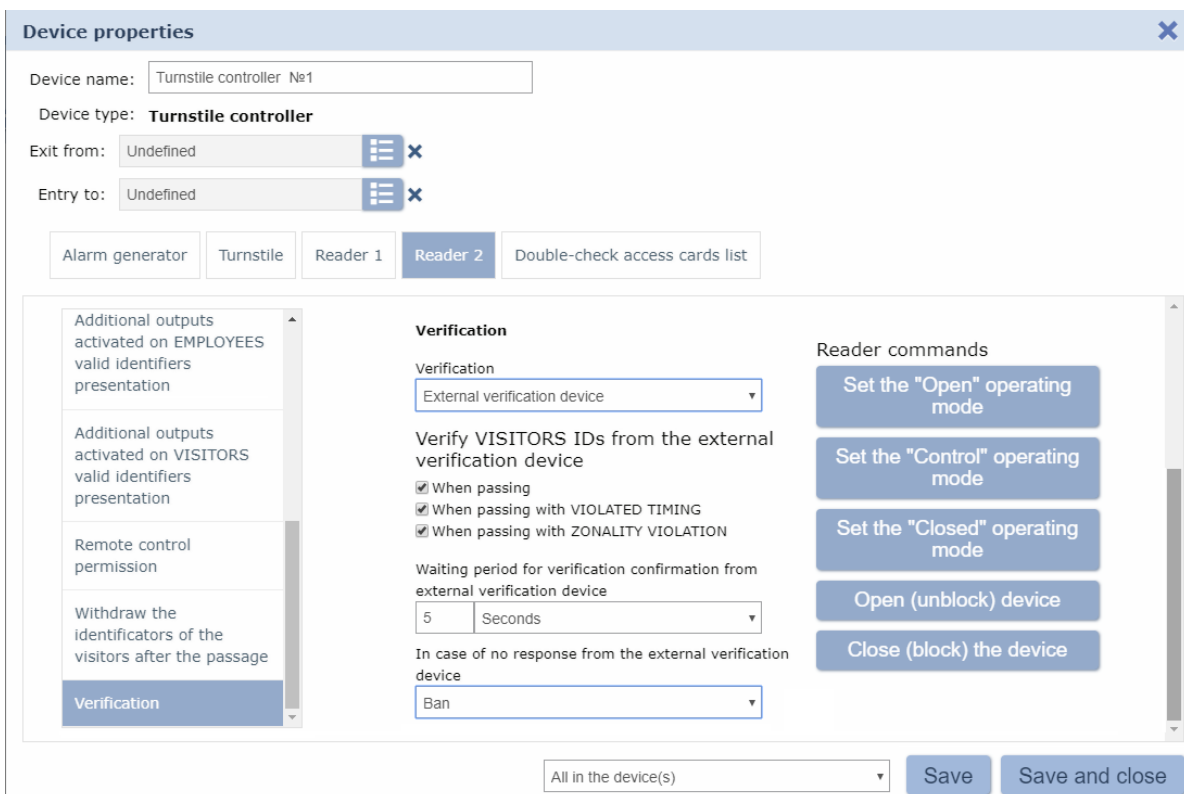

The screenshot shows the "Device properties" window for a "Turnstile controller №1". The "Reader 2" tab is selected. The "Verification" section is expanded, showing the following settings:

- Verification: External verification device
- Verify VISITORS IDs from the external verification device:
 - When passing
 - When passing with VIOLATED TIMING
 - When passing with ZONALITY VIOLATION
- Waiting period for verification confirmation from external verification device: 5 Seconds
- In case of no response from the external verification device: Ban

On the right side, there are "Reader commands" buttons: "Set the 'Open' operating mode", "Set the 'Control' operating mode", "Set the 'Closed' operating mode", "Open (unblock) device", and "Close (block) the device". At the bottom, there are "Save" and "Save and close" buttons.

16. In the left part of the working area tab select "Additional outputs activated upon VISITORS valid identifiers" parameter and set:
- set "For the operation time" value for the "Activation criteria" parameter by using the drop-down list.
 - in the pop-up list of additional outputs check "Additional output No.3" (number of the output that is connected to the "Capture card" input of the card capture reader).

17. In the left part of the tab select **‘Withdraw the visitors’ identifiers after the passage** parameter and check the box:

18. Click **“Save and close”** button. The **"Device properties"** window will be closed; the settings are saved.

5.4.2 CT/L14, CT13 configuration in Web-interface for working with the card capture reader

1. In **"Configuration" → "Edit" → "Operating devices"** section, select the OD that is physically connected to the card capture reader, then in OD parameters select **"Access by directions"**

and directions number that is controlled by the card capture reader. Set the following parameters for this direction:

- in **"Verification"** parameters group for **"Visitor pass external device verification:"** parameter – value **"Yes"** and also set the necessary values of parameters **"Visitor external device verification activation:"** and **"External device waiting period:"**.
 - in the table of verification sources in the first cell, set the value **"External verification device"**.
2. In **"Configuration"** → **"Edit"** → **"Physical contacts"** section:
- set the following parameter values for input that is physically connected to the *"Card captured"* output of the card capture reader:

Physical contact - input

Contact: In5

Function: External verification device confirmation input

Operating device: 1

Direction: 1

Normal: Cut

Anti-Bounce: 20 MC

Delete Save Cancel

- **"Function:"** – **"External verification device confirmation input"**
 - **"Operating device:"** – **"1"** (number of OD that is physically connected to the card capture reader),
 - **"Direction:"** – **"1" or "2"** (depending on the passage direction that is controlled by the card capture reader):
 - **"Normal:"** – **"Cut"**,
- Set the following parameter values for the output that is physically connected to the *"Capture card"* input of the card capture reader:
 - **"Function:"** – **"Output"**:
 - **"Normal:"** – **"Not energized"**,

Physical contact - output

Contact: OK1

Function: Output

Operating device: 1

Direction: 1

Normal: Not energized

Delete Save Cancel

3. Add the following Internal response in **"Configuration"** → **"Edit"** → **"Internal responses"** section:
- **"Source type:"** – **"Visitor ID card presentation"**,
 - **"Source number:"** – **"1"** (number of OD that is physically connected to the card capture reader),

- **"Source direction:"** – **"1" or "2"** (depending on the passage direction that is controlled by the card capture reader),
- **"Receiver type:"** – **"Activate output"**,
- **"Receiver number:"** - **"1"** - (number of the output that is physically connected to the "Capture card" input of the card capture reader),
- **"Response characteristic:"** – **"Response time"**:

4. Any free input of the controller can be used for receiving the "Alarm" signal sent by the card capture reader. It is necessary to set the type of response on the activation of this input, for example, activate alarm output:

5. Temporary cards for visitors can be issued in **"Access"** → **"Users"** section of the Web-interface. When adding a new user:
 - on the **"General rights"** tab select **"Visitor"** value for the **"Type"** parameter,
 - on the **"Individual rights"** tab for the OD controlled by the card capture reader, set the appropriate access rights and verification criteria for the visitor, while for the **"Verify from external verification device:"** parameter set the value **"Yes"**, while the value of the **"Blocked:"** parameter for this set of rights should be **"No"**.

5.4.3 CT/L04.2, CT03.2 configuration in Web-interface for working with the card capture reader



Attention!

By using Web-interface it's possible to set only the simplest visitor's card withdrawal algorithm, to amplify the setting range, use **PERCo-Web** software. The **CT/L04 (CT03)** controllers are not compatible with configuration via Web-interface.

1. In "**Configuration**" → "**Edit**" → "**Operating devices**" section, select the OD that is physically connected to the card capture reader, then select "**Reader 1**" or "**Reader 2**" depending on the direction of the passage that is controlled by the card capture reader. Set the following parameters for the reader:
 - set the "**External verification device**" value for the "**Verification**" parameter,
 - within the "**External device verification in ACM**" "**Control**" group of parameters set "**Yes**" value for the "**Visitor pass verification**" parameter and also set the required values for "**Visitor verification activation**" and "**External device verification waiting period**" parameters.
2. Set the following parameters in "**Configuration**" → "**Edit**" → "**Physical contacts**" section:
 - set the following parameter values for input that is physically connected to the "Card captured" output of the card capture reader:
 - "**Normal state:**" – "**Cut**",
 - "**Function:**" – "**External verification device confirmation input**",
 - "**Operating device:**" – "**1**" (number of OD that is physically connected to the card capture reader),
 - "**Direction:**" – "**1** or **2**" (depending on the passage direction that is controlled by the card capture reader):

Physical contact Input 6 (loop)

Normal state: Cut

Function: External verification device confirmation input

Operating device: 1

Direction: 1

Save Cancel

- Set the following parameter values for the output that is physically connected to the "Capture card" input of the card capture reader:
 - "**Normal state:**" – "**Not energized**",
 - "**Function:**" – "**Output**":

Physical contact Output 3

Normal state: Not Energized

Function: Output

Save Cancel

3. Add the following Internal response in **"Configuration" → "Edit" → "Internal response"** section:
 - **"Source type:"** – **"Visitor ID card presentation"**,
 - **"Source number:"** – **"1"** (number of OD that is physically connected to the card capture reader),
 - **"Source direction:"** – **"1"** or **"2"** (depending on the passage direction that is controlled by the card capture reader),
 - **"Receiver type:"** – **"Activate output"**,
 - **"Receiver number:"** – **"3"** (number of the output that is physically connected to the "Capture card" input of the card capture reader),
 - **"Response characteristic:"** – **"Response time"**:

Internal response 1

Number: 1

Source type: Visitor ID card presentation

Source number: 1

Source direction: 1

Receiver type: Activate output

Receiver number: 3

Receiver direction: 1

Response time: No

Response characteristic: Response time

Reset of the guard zone output in «ALARM» mode: No

Save Cancel

4. Any free input of the controller can be used for receiving the "Alarm" signal sent by the card capture reader. It is necessary to set the type of response on the activation of this input, for example, blocking of the reader in the passage direction that is controlled by the card capture reader:

Internal response 2

Number: 2

Source type: Input

Source number: 5

Source direction: 1

Receiver type: Block reader

Receiver number: 1

Receiver direction: 1

Response time: No

Response characteristic: Response time

Reset of the guard zone output in «ALARM» mode: No

Save Cancel

Example of an overview of the sections **"Internal response"** and **"Physical contacts"** after configuration (template – "Turnstile" card capture reader controls the direction number "1", "Input 6" and "Output 3" are used to control the card capture reader, "Input 5" is used receive the "Alarm" signal:

Add						
Number	Source			Receiver		
	Type	Number	Direction	Type	Number	Direction
1	Visitor ID card presentation	1	1	Activate output	3	1
2	Input	5	1	Block reader	1	1

Contact	Function	Operating device	Direction	Normal
Input 1	Pass input	1	1	Closed
Input 2	Pass input	1	2	Closed
Input 3	Not specified			Cut
Input 4	Not specified			Cut
Input 5 (loop)	Input			Cut
Input 6 (loop)	External verification device confirmation output	1	1	Cut
Input 7	Remote control	1	1	Cut
Input 8	Remote control	1	3	Cut
Input 9	Remote control	1	2	Cut
Input 10	Fire alarm input			Closed
Output 1	Operating device control output	1	1	Not energized
Output 2	Operating device control output	1	2	Not energized
Output 3	Output			Not energized
Output 4	Not specified			Not energized
Output 5	Not specified			Not energized
Output 6	Not specified			Not energized
Output 7	Remote control indication output	1	1	Energized
Output 8	Remote control indication output	1	3	Energized
Output 9	Remote control indication output	1	2	Energized

5. Temporary cards for visitors can be issued in **"Access cards"** section of the Web-interface. First, include them into the main list of cards in the **"Input"** subsection, then in the **"List"** subsection, select the proximity card that should be issued for a visitor, and in the opened window:

- on the **"General"** tab select **"Temporary"** value for the **"Card type"** parameter, then determine the period of validity of the card,
- on the **"Access rights"** tab set the **"Yes"** value to **"Verification"** parameter for reader 1 or 2 (depending on the direction of the passage is controlled by the card capture reader), in this case, the **"Status"** of this set of rights should be **"Unblocked"**.

The image shows two side-by-side screenshots of a software interface for configuring access rights. Both windows have a title bar with the number '65555' and a close button.

The left window has two tabs: 'General' (selected) and 'Access rights'. Under 'General', there are several fields:

- Card type: Temporary (dropdown)
- Valid from: 01/10/2018, Hour: 10, Min.: 15
- Valid till: 01/10/2018, Hour: 17, Min.: 30
- Stop list: No (dropdown)
- Vehicle card: No (dropdown)
- Full name: Visitor| (text input)

 At the bottom are buttons for 'Delete', 'Save', and 'Cancel'.

The right window also has two tabs: 'General' and 'Access rights' (selected). Under 'Access rights', there are several fields:

- Card rights number: 1 (dropdown)
- Access time interval: Time zone (dropdown)
- Time criteria number: 0 (text input)
- Guard zone number: 1 (dropdown)
- Access permissions: Permitted (dropdown)
- Other cards double-check: No (dropdown)
- Antipassback: No (dropdown)
- Verification: Yes (dropdown)
- Status: Unblocked (dropdown)

 At the bottom are buttons for 'Delete', 'Save', and 'Cancel'.

6 PERCO WARRANTY

PERCo (the Manufacturer) warrants that the **FP-01C Front panel** (the Product) complies with applicable statutory safety requirements, electromagnetic compatibility provided that the instructions on storage, installation and operation, given in the Assembly & Operation Manual, are observed.

The warranty period is **5 (five) years** commencing from the date of sale.

Should there be no date of sale on the warranty card, the warranty period shall commence from the date of manufacture specified in the Certificate and on the Product label.

In the post-warranty period the replacement parts/components are warranted to be free from defects in material or workmanship for a period of 3 (three) months from the date of shipment of the repaired/replaced Product to the Customer.

All claims with regard to quantity, completeness and defects to appearance of the Product delivered are accepted by the Manufacturer in writing within no more than 5 (five) working days after the products are received by the Customer. In case of failure to meet the abovementioned deadline no claims are accepted.

The Warranty does not cover:

- products, parts and components with:
 - external mechanical damages resulting in the Product's fault;
 - defects resulting from Customer's improper testing, operation, installation, maintenance, modification, alteration, or adjustment;
 - damages due to force majeure circumstances (natural disasters, vandalism etc.) or defects as a result of external circumstances (power surges, electric discharge, etc);
- fuses, accumulators, galvanic elements and other components, replacement of which is performed by the Customer in accordance with the Product's in-line documentation.

To the maximum extent permitted by the acting law, the Manufacturer does not incur a liability for any direct or indirect losses of the Customer, including but not limited to loss of profit or data, losses caused by idle period, missed profit, and etc. related to use or impossibility to use products and software, including possible software errors and failures.

Within the warranty period the products are repaired free of charge at the Manufacturer's site. The Manufacturer reserves the right to repair failed product or replace it with an operational one. Time of repair is specified at the moment the Product is accepted for repair. Transportation cost to and back from the place of repair shall be borne by the Customer.

In order to shorten the repair time the Customer must inform the Manufacturer's Technical Support Department (the TSD) of the problem with the Product's operation and/or about the origin of the fault by submitting a filled-in Technical Support Form by e-mail, fax or via the Manufacturer's website or communicate directly a specialist of the TSD.

The Manufacturer reserves the right not to accept the Product for repair from the Customer who failed to submit the Technical Support Form.

The Manufacturer's warranty obligations don't cover attendance by the experts of a Customer and maintenance of any Product on site

If in the course of the examination taken by the Manufacturer of the Product or its parts/components believed to be faulty, no faults have been detected, the Customer is responsible for compensation of the Manufacturer's expenses related to the examination.

Apart from the warranties mentioned above the Manufacturer does not provide any other warranties with regard to compatibility of a Product purchased with software or products produced by other manufacturers as well as any warranties that this Product will fit for the purposes not stipulated in the Product's in-line documentation.

The warranty does not provide for any claims with regard to the technical specifications of the Product in case they are in compliance with those stated by the Manufacturer. The Manufacturer does not guarantee that the Product purchased will meet Customer's requirements and expectations.

PLEASE NOTE THAT PERCo PRODUCES TECHNICALLY SOPHISTICATED PRODUCTS THAT, IF NOT FAULTY, CANNOT BE RETURNED BACK IF BY SOME REASON THE CUSTOMER DEEMS THEM UNSATISFACTORY



The PERCo **FP-01C Front panel** is in conformity with the essential requirements of the EU's Machinery, Low-Voltage and EMC Directives and carries the CE marking accordingly.

WARRANTY CARD



FP-01C Front panel with a built-in card capture reader for ST-01

Serial number	6	9	6					/					
---------------	---	---	---	--	--	--	--	---	--	--	--	--	--

Date of manufacture: _____ 20__

Quality Control Seal:

Date of sale: « » _____ 20__

(signature, seal)



Cutting line

Warranty Repair Coupon



FP-01C Front panel with a built-in card capture reader for ST-01

Serial number	6	9	6					/					
---------------	---	---	---	--	--	--	--	---	--	--	--	--	--

Date of manufacture: _____ 20__

Quality Control Seal:

Date of sale: « » _____ 20__

(signature, seal)

